

Ground Search & Rescue

SAR100
Participant Manual



Emergency
ManagementBC

Acknowledgement

This review and revision of the Basic Search and Rescue Manual is a collaborative effort involving many people. The combined expertise, experience and effort of these people have led to a manual that is much more reflective of the field's actual requirements.

Ground Search and Rescue Advisory Committee

Don Blakely - Vernon SAR
Carl Doey - Sparwood SAR
Art Eickmeyer - Prince George SAR
Linda Hillard - Victoria SAR
Paul Kindree - Squamish SAR
Richard Laing - Ridge Meadows SAR
Wayne Merry – Atlin SAR

Hamish Murray – Comox Valley SAR
Shelly Ohland - Ft. St. John SAR
Michael Pavich – Rescue 15 (Prince Rupert)
Pete Wise - Vernon SAR
Dennis Zaharoff - Barriere SAR
Geoff Amy – PEP

Special recognition goes to:

Andrew Spray, who was the principal author of the original Basic Search and Rescue Manual for BC.

Wayne Merry, whose Basic Ground Search and Rescue in the Yukon Territory Manual has been used as the basis for some sections of the GSAR Manual.

Gord Sweeting, who distilled the information from the study guide for the Radiotelephone Operator's Restricted Certificate for inclusion in the Communication Chapter.

Martin Colwell, whose research on Sweep Searches is the basis for the Sweep Search Chapter.

Dave Brewer, whose information on conducting a SAR operation review was used in the Search Termination Chapter.

All the participants at the GSAR Instructor Workshops who provided verbal and written feedback on the GSAR course and manual.

Emergency Management Division

Peter Pershick	Director
Linda West	Supervisor, Administrative Services

Search and Rescue Training

Jon Heshka	Program Coordinator
Stuart MacDonald	Instructor/Coordinator
Sandy Hamilton	Program Assistant

This is the second edition of the GSAR manual. Many suggestions were forwarded from the users of the manual and these have been incorporated into this edition. The first edition was dated 1998 (in the footer) while the second edition is dated 1999. A revision sheet listing the changes made to the first edition is available upon request.

© 1999, Justice Institute of British Columbia

All rights reserved. The use of any part of this publication reproduced, transmitted in any form or by any means, electronic, mechanical, photocopying, recording, or otherwise, or stored in a retrieval system, without the prior written consent of the copyright owners is an infringement of copyright law.

First Edition - November, 1998

Second Edition - July, 1999

Additional copies of this manual may be ordered from:

Emergency Management Division
Justice Institute of British Columbia
715 McBride Blvd.
New Westminster, BC

Phone (604) 528-5786

Fax (604) 528-5798

Canadian Cataloguing in Publication Data

Main entry under title:

Ground search and rescue. – 2nd ed.

“Provincial Emergency Program.”
Includes bibliographical references: p.
ISBN 0-7726-3964-7

1. Search and rescue operations – Handbooks, manuals, etc. 2. Rescue work – Handbooks, manuals, etc. I. Justice Institute of British Columbia. Emergency Management Division.

GV200.5.G76 1999

363.34'81

C99-960262-4

Ground Search and Rescue (GSAR) Manual Second Edition

Table of Contents

Introduction

1. Search and Rescue in British Columbia (BC)

Search Organization

2. Initiating a Search
3. Search Progression
4. Search Termination

Wilderness Navigation

5. Maps
6. Compass
7. Map and Compass

Searcher Skills

8. Survival Skills
9. Communications
10. Orientation to Rope Management
11. Orientation to Tracking
12. Helicopter Safety
13. Avalanche Orientation
14. Evacuation

Search Tactics

15. Type I Methods – Initial Response Searches
16. Type II Methods – Sweep Searches
17. Type III Methods – Closed Grid Searches
18. Shoreline Searches and Safety

19. Chapter Review Answer Key

20. Bibliography and Index

Chapter 1 - Search and Rescue in BC

Upon completion of this chapter, you will be able to:

- Describe the three basic categories of search and rescue (SAR).
- Describe specifically the jurisdictional mandates of the Department of National Defence (DND), the RCMP and municipal police forces, the Provincial Emergency Program (PEP), the BC Ambulance Service (BCAS), and the Coroner's Service.
- Outline PEP's SAR Policy as it relates to:
 - Workers' Compensation Board (WCB)
 - Liability insurance
- Outline the SAR training course structure in BC.
- Outline the roles and responsibilities of the
 - Emergency Coordination Centre (ECC)
 - Regional Manager
 - SAR (Incident) Commander
 - Emergency Program Coordinator
 - SAR Manager (Deputy Incident Commander)
 - SAR Team Leader
 - SAR Advisory Committee
 - Volunteer SAR Regional Representative
 - Rescue Coordination Centre (RCC)
 - PEP Air Service
- Outline SAR agreements between PEP and the RCMP, municipal police forces, the Coroner's Service, Workers Compensation Board of BC and Parks Canada.
- Explain the following components of SAR operations:
 - preplanning
 - notification
 - planning/strategy
 - tactics/operations
 - suspension/termination
 - review
- Describe the functions of the Incident Command System (ICS).

Vision Statement

Ground Search and Rescue (GSAR) team members:

1. are dedicated volunteers who must possess the skills necessary to perform SAR related tasks with a high degree of proficiency;
2. must act professionally and follow a code of conduct which relies heavily on trust, integrity and teamwork;
3. must be able to follow directions, work with limited supervision, have strong communication skills, be able to assess risk and complete tasks without endangering themselves or others.

Introduction

As search and rescue (SAR) volunteers registered with the Provincial Emergency Program (PEP), it is necessary to appreciate and understand a sense of the “big picture”. Consequently, chapter one deals with SAR organization, agreements and training schemes.

Like all areas of emergency response, the field of ground search and rescue is in a continuous state of improvement and evolution. It is undergoing great change due to increasing technology, the development of alternate and improved techniques, the integration of volunteers and professionals, and concerns with legal liability, standard of care and negligence.

This reference is intended to serve as both an operational manual for the PEP and as a training manual administered and managed by the Justice Institute of BC to which PEP-registered SAR volunteers must refer to in order to become a certified ground searcher. This edition updates the initial version primarily written by SAR volunteer and former regional advisory representative Andrew Spray and published by the JIBC in 1989.

Publication of this edition involved review and revision of the existing program by an advisory panel. This advisory panel was comprised of volunteer search and rescue representation from across British Columbia. They were consulted and have provided constructive feedback to the development of the new GSAR manual.

This manual effectively replaces the Basic Search and Rescue Manual produced and distributed by the JIBC. It is now regarded as the training and operational manual in **Ground SAR** for PEP and the Royal Canadian Mounted Police within the Province of British Columbia.

Intent

This manual has been prepared to present a minimum operating standard or guideline for ground searchers in BC. Personnel should possess certification in GSAR in order to be deployed into the field.

SAR Categories

SAR is inherently dangerous. There should always be a conscious effort to balance the benefits against the costs of conducting a search or a rescue. SAR requires ground searchers to make informed decisions as opposed to ignorant guesses in the field. The consequences of making a wrong decision may be fatal or at least terribly inconvenient.

The GSAR Course is more than merely reading the manual. SAR is a serious undertaking and requires an enormous degree of commitment and effort. Ground SAR cannot be learned merely from a book. This manual is regarded as a reference guide to assist the ground searcher in improving their field skills.

Competency requires expert instruction, supervision, field exercises and practice. Only then will the ground searcher possess the knowledge, skills and abilities necessary to safely and swiftly perform their task. It is expected that the manual will be used in conjunction with standardized training provided by volunteer instructors and co-ordinated through the Justice Institute of BC.

SAR operations within British Columbia fall into three basic categories: **Air SAR**, **Marine SAR**, and **Ground and Inland Waters SAR**.

Jurisdiction

When a SAR Emergency arises, the primary responsibility for the response depends on the category of search and/or rescue involved. Jurisdictional authority and responsibility for SAR operations is divided among several federal and provincial governmental departments and is supported by volunteer SAR Groups.

Department of National Defence (DND)

Both air and marine search and rescue are a federal responsibility. **Air SAR** is the responsibility of the **Canadian Armed Forces**. **Marine SAR** is the responsibility of the **Canadian Coast Guard**. Marine SAR is supported by the volunteer Canadian Coast Guard Auxiliary. Both air and marine SAR are coordinated by the **Rescue Coordination Centre (RCC)** in Victoria.

Police Authority

The authority and responsibility for **Ground and Inland Water SAR** within the province of BC ultimately falls to the **police detachment having jurisdiction**. Throughout most of BC, this is the Royal Canadian Mounted Police (RCMP) while in thirteen communities it is municipal police forces.

Provincial Emergency Program

The Provincial Emergency Program (PEP) is part of the Ministry of Attorney General. In cooperation with other ministries and agencies, PEP advises and assists in preventative measures, and coordinates the emergency preparedness, response and recovery measures of the provincial government. PEP encourages and assists local governments to develop and exercise local emergency plans.

Specific to SAR, PEP is responsible for facilitating the maintenance of a provincial ground and inland water SAR capability and assisting in coordinating the operational response of local SAR volunteer groups when requested by the police, BC Ambulance Service (BCAS), Department of National Defence (DND) or other agencies.

At present, PEP and the police authorities have a non-written agreement that PEP will provide SAR services when requested to do so by the RCMP or municipal forces. The intention is that PEP will act in support of the police authority's ultimate responsibility for SAR within British Columbia.

PEP supports authorized SAR activities providing individuals with Worker' Compensation Board (WCB) coverage, third party liability insurance and legal representation as a result of losses or claims arising out of authorized operations and pre-approved training tasks. PEP will reimburse SAR volunteers for expenses incurred during operations and sometimes for training. PEP will replace some or all of essential equipment lost or damaged during an operation but not on training tasks. PEP will not purchase the SAR Group's initial capital outlay of equipment.

It should be realized that PEP's mandate covers more than SAR. PEP is involved in emergency planning, emergency preparedness and emergency social services.

BC Ambulance Service Coroner's Service

The BC Ambulance Service (BCAS) is the agency with whom SAR Groups interact with when the subject is injured in a known location and requires pre-hospital care.

In the event that human remains are located, the matter becomes the responsibility of the Office of the Provincial Coroner who often act through the local police.

There is a written agreement between the Office of the Chief Coroner of BC, the RCMP and the Provincial Emergency Program which states that:

- SAR volunteers who are involved in police directed SAR operations may assist in or effect a body recovery under the direction of a Coroner or other person as provided under the Coroner's Act;
- SAR volunteers may be tasked to assist in or effect a body recovery in instances which do not begin as SAR operations, and which are initiated as operations to recover a deceased person(s).

Workers' Compensation Board Coverage

There are two written agreements between the Government of Canada and the Government of British Columbia. They use the term "Emergency Services Worker" to refer to what includes search and rescue personnel. It states that:

- Where the Workers' Compensation Board (WCB) decides that an accident causing death or injury arose out of and in the course of "Emergency Services Work", it shall determine and pay the amount of compensation and provide medical aid including rehabilitation and retraining costs, according to the Workers' Compensation Act of BC.
- "Emergency Services Work" means work, for no compensation, which is designed or intended to protect and preserve life, property, the environment or public services in the event of an emergency ...and includes training therefor.
- "Emergency Services Worker" defines any person who has volunteered for Emergency Services work and has been registered with the Provincial Emergency Program for volunteer Emergency Services.

Further information regarding WCB, insurance and liability protection is located in the PEP brochure included with this manual.

SAR Training

Under the direction of the Provincial Emergency Program and in consultation with experienced SAR volunteers, the Emergency Management Division – PEP Academy at the Justice Institute of BC is responsible for developing, and designing the course curriculum, standards and evaluation practices for SAR volunteers in BC.

Course delivery is done either through the PEP Academy directly, or at the regional or local level with either the assistance of PEP funding or local fundraising efforts. Regionally-based SAR courses like Ground Search Team Leader, Rope Rescue, SAR Management and Organized Avalanche Response are co-ordinated by the Justice Institute of BC.

Figure 1.2 (located at the end of Chapter 1) depicts the Conceptual Framework for SAR Training in BC. Note: some of the listed courses have not been developed as of 1999.

ECC

The Emergency Coordination Centre (ECC), situated at PEP headquarters (PEP HQ) in Victoria, operates 24 hours a day, 7 days a week to provide a central coordinating agency for all routine provincial emergency response activities, particularly those for which the Ministry of Attorney General/PEP is the key ministry. Specific activities include:

- receiving notification of emergency incidents, records information and notifies applicable agencies;
- maintaining a chronological event log of all calls received and made; and
- allocating funds from the Emergency Assistance Vote for emergency responses on the direction of Regional Managers and PEP HQ Management.

In regards to SAR, ECC responsibilities include:

- Issuing task numbers to SAR Managers and Emergency Program Coordinators. A SAR response is not authorized by PEP unless a task number has been issued. To receive a task number, SAR Group assistance must be requested by the RCMP/Local Police, BC Ambulance Department of National Defence (DND) or other agencies.
- Notification of PEP Regional Managers of all SAR activity 24 hours a day, 7 days a week. See responsibilities of PEP Regional Managers listed below. Notification of SAR activities as and when required to PEP HQ staff including PEP SAR Coordinator and the Deputy Director.

PEP Regional Manager

There are six PEP regions with a PEP Regional Manager (RM) and an Administrative Assistant in each, except for the Southwest Region Office which has an Assistant Regional Manager and second Administrative Assistant. PEP Regional Manager responsibilities include:

- Providing assistance to local governments and other ministries in emergency preparedness, response and recovery.
- Receiving training task applications, approving requests for funding and forwarding them to headquarters; and

In regards to SAR incidents, PEP Regional Manager responsibilities include:

- Providing assistance and/or coordination as and when required on a 24 hour basis to SAR Managers and other agency representatives to enhance SAR response. Aside from having a comprehensive knowledge of SAR operations, PEP Regional Managers have resources such as helicopters and other agency personnel at their disposal to assist with SAR incidents.
- Approval of costs associated with SAR incident task numbers, helicopter and fixed wing use as well as equipment such as snowmobiles and ATV's.

SAR (Incident) Commander - Police Authority

The SAR Commander (usually a police officer) is ultimately responsible and retains authority over the SAR operation. However, management of SAR operations is usually delegated to qualified SAR personnel. The delegation of responsibilities does not mean that the police have forfeited their authority over the incident. The police remain in charge.

It is a police decision whether or not to use a SAR Group.

The SAR Commanders responsibilities include:

- Conducts pre-investigation prior to initial notification of PEP SAR Manager.
- Continues investigation regarding operation (may be done in conjunction with the SAR Manager).
- Contacts either the SAR Manager, Emergency Program Coordinator or PEP ECC to initiate the search and/or rescue .
- Initiates the start of the operation.
- Determines the extent of the operation.
- Determines suspension and termination of the operation.
- Maintains a liaison with the SAR Manager during the operation.
- Accesses police resources (search & tracking dogs, Forward Looking Infra-Red, helicopters).
- Develops and maintain the SAR operation progress report.
- Liases with the media and the subject's family.
- Chairs and contributes to operational reviews.
- Oversees body recovery for the Coroner's office.

Emergency Program Coordinator

In most cities or municipalities there is an emergency program that is directed by the Emergency Program Coordinator. However, the relationship between the SAR Group and the Emergency Program Coordinator varies considerably between municipalities.

Responsibilities include:

- possibly receiving the initial search or rescue call-out from police or from the SAR Manager
- may call ECC to get a task number, report the incident, provide daily updates and for task closure
- possibly notifying and contacting the SAR Manager for group call-out
- liaising with the SAR Manager and the police regarding the operation
- functioning as the official link with municipal government and provincial ministries
- functioning as the official link between the SAR Group and PEP Regional Offices
- representing local, municipal or regional district government interests
- liaising with the PEP Regional Manager to request additional resources and for information updates

Search and Rescue Groups

SAR Manager (Deputy Incident Commander)

It must be remembered that the responsibilities of the Emergency Program Coordinator are not restricted to SAR activities.

GSAR team members are an essential component of ground and inland water SAR in BC. There are presently 75 active SAR Groups in BC comprised of approximately 5000 volunteers. GSAR team members volunteer tens of thousands of hours annually towards SAR operations and training.

The person who will lead the SAR Group during the operation is called the SAR Manager (Deputy Incident Commander). This person should be an experienced member of the group with good leadership skills.

Responsibilities include:

- Receives initial call-out usually from the police but may be from the emergency program coordinator or ECC.
- May contact ECC for acquisition of an operational task number.
- Manages the SAR Group during the operation.
- Liases with the police and possibly PEP Regional Manager during the operation.
- Manages the SAR operation with police permission and consent.
- Initiates SAR Group call-outs.
- Manages incident out of the Incident Command Post (SAR Base).
- Initiates other SAR Group mutual aid.
- Determines the strategy and tactics of search operations.
- Allocates SAR Group resources to the field.
- Oversees SAR Group functions and PEP requirements.
- Evaluates rescue requirements and allocates as necessary to the field.
- Delegates rescue operation control to the rescue team field leader.
- Initiates and may chair operation review.
- Completes required PEP registration and task reports.
- Provides daily updates to ECC and report task closure.

Team Leader

During a SAR incident a group of volunteers may be sent into the field as a team. One person will be designated the Team Leader. There are various types of team leaders in SAR such as Ground Search Team Leader (GSTL), Rope Rescue Team Leader, or Swiftwater Rescue Team Leader. The role of the team leader is to supervise and monitor the conduct and activities of the team. This includes:

- Safety
- Performance
- Supervision
- Accountability
- Logistics
- Briefing
- Review
- Communications
- Record keeping
- Liaising with the SAR Manager

SAR Advisory Committee

In 1990 the SAR Advisory Committee was formed to:

- Advise PEP on SAR policy, legislation, standards, resources, training and related priorities;
- Provide channels of communication among participating SAR Groups as well as between agencies such as the RCMP and the PEP;
- Facilitate the establishment of a standards and assessment group to ensure one standard of SAR is adopted for the province and to assess the quality of delivery of the service.

The members of the SAR Advisory Committee include:

- SAR Coordinator (volunteer) appointed as Chair.
- Eight (8) volunteer SAR Regional Representatives
- RCMP Representative
- Municipal Police Representative
- PEP SAR Coordinator
- JIBC SAR Training Program Coordinator

Volunteer SAR Regional Representative

The volunteer SAR Regional Representative is selected from the SAR Groups in the region. The SAR regional rep duties include:

- Provides communication between SAR Groups, the Regional Manager, the SAR Advisory Committee, police, PEP headquarters, the Justice Institute, etc.
- Creating regional training plans in consultation with SAR Groups in their area, the Regional Manager and the Justice Institute.
- Hosting an annual regional workshop/meeting.
- Involvement in issues relating to mutual aid.

RCC

The Canadian Forces Rescue Coordination Centre (RCC) in Victoria is responsible for the coordination of all air and marine search and rescue activities within the province. The RCC maintains a squadron of both fixed and rotary winged aircraft at the Canadian Forces Base in Comox and coordinates the deployment of marine vessels located throughout many communities in British Columbia.

During an air or marine SAR operation, the RCC may request the services of PEP SAR Groups or PEP Air/CASARA (Civil Air Search and Rescue Association).

PEP Air/CASARA

PEP Air consists of volunteers, whose interests lie with aviation and who dedicate their time and/or aircraft to assist PEP, Search and Rescue Groups, Canadian Armed Forces or the Canadian Coast Guard. PEP Air crews operate under the volunteer umbrella of the Civil Air Search and Rescue Association (CASARA).

Each PEP region of BC has a commander who is the coordinator for all air volunteers in the region. The commander is responsible to the PEP Regional Manager and is the regional manager's advisor during SAR operations involving the use of fixed wing aircraft. PEP Air may be called upon to respond to requests from PEP and may be of particular assistance in spotting parked vehicles, locating overturned boats, and acting as a communications platform. The PEP Air Service contact with the Province is through the PEP Regional Manager.

Parks Canada

There is a written agreement between Parks Canada and PEP which states that:

- It is the intent of PEP and the Canadian Parks Service to assist each other in BC and in Federal Parks within BC with personnel, equipment or other resources in any emergency or disaster as deemed appropriate.

SAR Components**Preplanning**

“Preplanning” is a term applied to the overall planning which occurs before an incident and addresses all phases of likely SAR situations. Good preplanning means being ready in terms of equipment, organization, management and training. In most cases, this is the most important, yet overlooked, component of the SAR incident cycle. A proper preplan can minimize the need for, and enhance the safety of every subsequent action. Lessons learned from previous situations provide the foundation for a preplan.

Notification	<p>First notice is the moment in time that an incident is made known to SAR personnel. SAR personnel are most often informed of a SAR incident by either the police directly, the Emergency Coordination Centre, their Municipal Emergency Program Coordinator or a SAR Manager from an adjacent SAR Group. Regardless of the reporting party, the SAR response now begins to take shape.</p>
Planning and Strategy	<p>As each SAR phase begins (ie. Locate, Access, Stabilize, Transport), situation-specific planning and strategy development arise from and compliment preplanning efforts and plans. This incident planning stage is where the details are developed regarding how the current incident will be managed.</p> <p>Investigation is usually the first stage of planning and involves the timely gathering of accurate information so that an effective assessment of the situation can be made. Once the initial investigation has been accomplished, a list of options are outlined with backup contingencies for optimum flexibility.</p> <p>A relative urgency rating is determined by weighting factors that might effect the risk to the subject(s) such as their age, skill level, equipment, weather conditions, etc. The specific level of urgency determines the speed and nature of the response by rescuers.</p> <p>Finally, just before the physical operation begins, goals and objectives are established for the first operational period. These objectives are key to the proper field operations being carried out.</p>
Tactics / Operations	<p>Once the incident strategy is laid out and the objectives have been established, the tactical component of the incident cycle can begin. This component of the cycle is where the plans are implemented and physically carried out in the field. Tactical assignments may include both passive (ie. Investigation, confinement, attraction, etc) and/or active (ie. Field searching, tracking) search techniques.</p>
Suspension	<p>At the end of a search, if the subject has been located, the search is terminated and the access phase can commence. However, if the subject has not been found, the decision to discontinue active search efforts is a difficult one which involves complex management issues that are rarely easy to resolve.</p> <p>Once there is no longer a need to continue the current phase for whatever reason (ie. Subject is located, access has been accomplished, stabilization is completed, or subject has been transported), suspension of that particular phase takes place. Incident suspension or termination occurs when an incident is called-off and resources are demobilized to ready status.</p>

In larger incidents, this may involve structured deactivation of multiple resources, pulling teams out of the field, dismantling facilities, completion of documentation, and returning resources to service. All of this takes planning and preparation, and should be addressed in the overall preplan long before it is required.

Review

After every incident, participants will realize that if they had to do it all over again, they would do some things differently. If these thoughts and ideas are not documented, they can be lost and future incidents are destined to relive past mistakes. This is one reason every incident should contain some type of evaluation.

It can be formal, involving every participant at a sit-down meeting, or informal, involving just a brief discussion of recent events. Whichever the case, it serves to document lessons learned and allows a basis for revision of the preplan.

ICS

The Incident Command System (ICS) is used to manage a SAR emergency incident or non-emergency event. It can be used equally well for both small and large situations. The system has considerable internal flexibility. It can grow or shrink to meet differing needs. This makes it a very cost-effective and efficient management system.

Organization of the ICS is built around five major management activities: Command, Operations, Planning, Logistics, Finance/Administration.

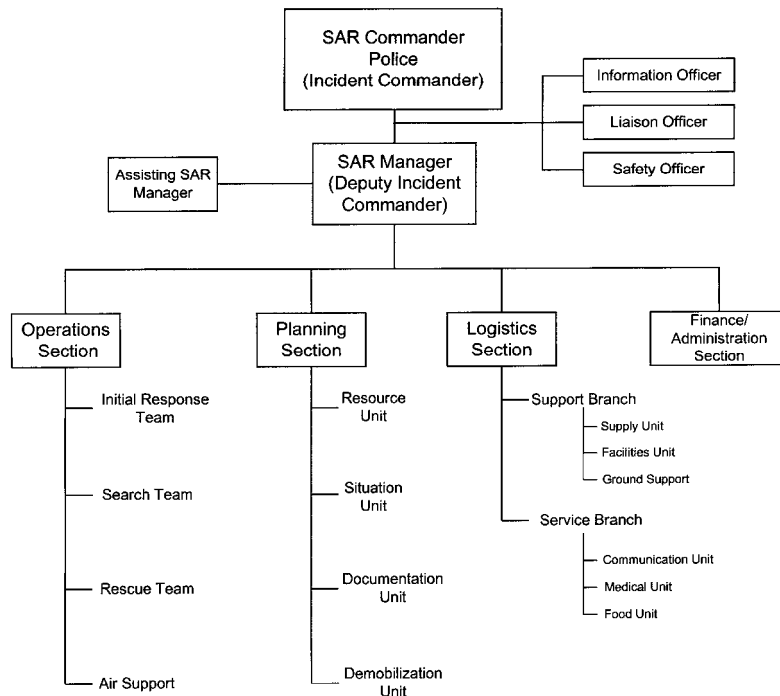

Figure 1.1 ICS Organization Chart

Command

- sets objectives and priorities
- has overall responsibility of the incident

As mentioned earlier, the Incident Commander (SAR Commander) is the police officer in charge. It is the Incident Commanders role to deal with the media and with the family and friends of the missing person. Sometimes this responsibility is handed over to the SAR Manager (Deputy Incident Commander) who may have a better understanding of what is happening in the field.

As the SAR Manager is more directly involved in the planning of the SAR tactics, the safety officer often reports directly to the SAR Manager instead of the Incident Commander.

Operations

- conducts tactical operations to carry out the plan
- develops the tactical objectives and organization
- directs all resources

Planning

- develops the Incident (SAR) Action Plan to accomplish the objectives
- the situation unit collects and evaluates information
- the resource unit maintains information on personnel and equipment status
- the documentation unit maintains all documents relevant to the incident

Logistics

- provides support to meet incident needs (eg. supplies, facilities)
- provides services (eg. communications, medical)

**Finance/
Administration**

- monitors costs related to incident
- provides accounting, procurement, time recording and cost analysis

ICS Forms

Throughout this manual standardized ICS forms are referred to and samples provided. These forms are available on the SARINFO web site at <http://www.sarinfo.bc.ca>.

The current PEP policy permits the use of SAR specific ICS forms as well as team specific forms.

Additional Resources

Provincial Emergency Program, Ministry of the Attorney General. *Policy and Procedures Manual*. 1998

Provincial Emergency Program. *Search and Rescue Advisory Committee, Information Booklet*. Victoria, BC, 1998.

SARINFO web site at <http://www.sarinfo.bc.ca>

Further references listed in the Bibliography.

Chapter Review

Please answer the following questions on a separate sheet of paper so that another student can use this manual. The answers to these questions are located at the end of the manual.

1. What are the three categories of Search and Rescue operations?
2. What is the mandate of the RCMP (or local police force)?
3. The _____ decides whether a Search and Rescue Group will be used on an incident.
4. Who supervises the activities of a SAR team in the field?
5. What are the three functions of the SAR Advisory Committee?
6. The _____ issues a task number for a SAR incident.
7. SAR volunteers may assist in a body recovery under the direction of the _____.

Answer **True** or **False** to the following statements:

8. SAR volunteers receive WCB coverage during training tasks.
9. ICS is only useful in large scale incidents.
10. The SAR Manager controls the budget for their region.
11. SAR training only occurs at the Justice Institute.
12. The operations section sets objectives and priorities for the SAR incident.
13. Demobilization is an important part of a preplan.
14. The Volunteer SAR Advisory Representatives are involved in determining training needs for their area.
15. PEP Air crews are paid staff of PEP.

Figure 1.2 A Conceptual Framework for SAR Training



Chapter 2 - Initiating the Search

Upon completion of this chapter, you will be able to:

- Explain why a rapid response is needed in SAR.
- Explain the call-out procedures for your area.
- Explain the use of the Relative Urgency Rating Chart.
- Travel in an appropriate manner to the rendezvous site.
- Describe the Missing Person Questionnaire used by SAR Managers for outlining information about missing persons.
- Explain sign-in procedures and why it is important to sign-in.
- Define the initial planning point (IPP), point last seen (PLS) and last known point (LKP).

Search is an Emergency

In the 1970's William Syrotuck analyzed data from searches in New York State and Washington State. He found that, on average, 11% of the search subjects were found dead. The percentage was higher (22%) for cool, wet conditions than for cold, dry conditions (2%) due to the effects of hypothermia.

Of the people who were found dead, 50% had died within the first day of being lost and a further 24% had died within the second day. This means that within 2 days of being lost, nearly $\frac{3}{4}$ of the subjects that will be found dead, have already expired. Therefore, it is necessary to initiate a swift response in order to reduce the likelihood of the lost person dying.

A Rapid Response is Crucial to Finding a Live Subject.

Another reason why a rapid response is crucial is that with a mobile subject, the search area grows with each passing hour. For example, if a person walked at 2.5 km per hour from the last known position for 3 hours the search area would be 177 square km. This is a large area to search! The sooner the search is initiated the smaller the area there is to search.

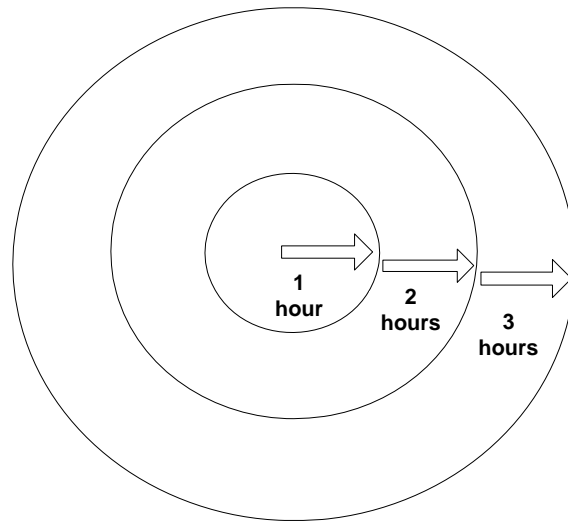

**Fig 2.1 After 2 hours the search area is 4 times larger.
After 3 hours the search area is 9 times larger.**

Modern search techniques are used to search areas effectively and efficiently. These techniques include:

- Building the search up rapidly (remember 74% of the subjects who die are dead within 2 days).
- Searching for clues not the subject (every subject leaves many clues).
- Searching for responsive subjects using techniques such as sound sweeps (to be discussed in a later chapter).
- Searching at night.

The Importance of Readiness

It is often impossible to be sure exactly how urgent any search will turn out to be. Today's "alive and responsible" search techniques require that the search teams are in the field and searching while the subject can still respond. The most effective searches expend considerable effort within the first 48 hours.

It is imperative that all GSAR members have personal equipment ready to go at all times. Keeping a ready pack "ready" is often a struggle for SAR volunteers as their gear is used for other activities besides SAR. However, once the pager goes off or the call comes in, time should not be wasted hunting for gear.

It is important that all GSAR members go into any wilderness search prepared to be unsupported for 24 to 48 hours, depending on local policy and conditions. If you are unprepared, support may not arrive in time and the search effort is hampered when searchers are forced to take care of themselves or each other. Remember, Murphy's Law likes nothing better than a search situation. *Go fast, but go prepared!*

Initial Call-out

When the police authority decides to activate a SAR Group, they may contact the Emergency Program Coordinator but most likely they will contact the **Duty Officer** (Duty SAR Manager) directly. The Duty Officer is usually one of the groups SAR Managers who, for a particular period of time, is the one person from the SAR Group who is always available to respond to the police. The manner in which the Duty Officer is contacted varies between SAR Groups with some using pagers, cell phones or regular phones. Many groups also have a backup Duty Officer who is also available should the Duty Officer be unavailable.

Once contacted, the Duty Officer will collect information. Two forms that are immediately used are the Relative Urgency Rating and the Missing Person. Although it is unlikely in an established SAR Group that a person with only Ground SAR training will be involved in the initial gathering of information, it is worthwhile knowing the kind of information that is used by the SAR Manager.

Relative Urgency Rating

The SAR Manager will use information collected to develop a relative urgency rating (Figure 2.2). Values are assigned to different factors affecting survivability and by totaling these values, a reasonable estimate of urgency of response can be determined.

Note that the lower the number, the higher the urgency. Circumstances such as young or old subjects, bad weather, no experience or inadequate equipment require a more urgent response. In some cases one situation alone may make it a serious emergency. A very young child, serious medical problem or severe weather are examples which might necessitate a rapid response.

Response Urgency Chart

The lower the numerical rating of the factor, the higher the relative urgency.

FACTOR	RATING	
SUBJECT AGE		
Very young	1	
Very old	1	
Other	2-3	
SUBJECT MEDICAL CONDITION		
Known or suspected injured, ill or mental illness	1-2	
Healthy	3	
Known fatality	3	
NUMBERS OF SUBJECTS		
One alone	1	
More than one (very young, very old)	1-2	
More than one (unless separation suspected)	2-3	
SUBJECT EXPERIENCE PROFILE		
Not experienced, does not know area	1	
Not experienced, knows area	1-2	
Experienced, not familiar with area	2	
Experienced, knows area	3	
WEATHER PROFILE		
Past and/or existing hazardous weather	1	
Predicted hazardous weather, (8 hours or less)	1-2	
Predicted hazardous weather, (more than 8 hours)	2	
No hazardous weather predicted	3	
EQUIPMENT PROFILE		
Inadequate for environment and weather	1	
Questionable for environment and weather	1-2	
Adequate for environment and weather	3	
TERRAIN/HAZARDS PROFILE		
Know hazardous terrain or other hazard	1	
Few or no hazards	2-3	
*Consider Elapsed Time in Response Determination	Factor Total	<input type="text"/>
<i>If any of the factors rate as a 1 regardless of totals, the search requires the highest urgency</i>		

Response Decision

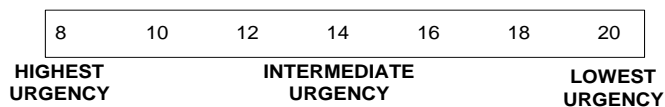

Figure 2.1 Response Urgency Chart

Missing Person Information

The SAR Manager will try to obtain as much information about the subject as possible from the police and will likely interview other people such as family, witnesses, or friends. The SAR Manager may use a Missing Person Questionnaire (ICS 302) to record this information.

The use of a form while collecting information ensures that all the information that may be useful is collected. If you review the form included at the end of this chapter, it will give you an idea of what type of information is collected. Many SAR groups teams have developed their own one or two page form for collecting this information.

An important part of the Questionnaire is the informant identification. This may be important if at a later time in the search further clarification is needed about some of the information.

Knowledge of the subject's **clothing** is useful in estimating survivability, in determining how **detectable** he may be and in identification of clothing found in the bush. It is not uncommon to find items of clothing in the course of a search, especially when a subject is seriously hypothermic and is losing or discarding clothing. As there is a surprising amount of litter on the backcountry, positive identification of such items is critical.

Clearly, complete knowledge of the subject's personal equipment and supplies will be essential to the searcher as such items are often found and become clues. A search team member should be absolutely sure that he has received all such information before searching an assigned area. If you have questions, ask!

Identification of **footprints** is key to many searches. Once the subject's print is identified, then discovery of only a thumbnail-size section of that print may be enough to change the direction of a search. A few years ago, charts of individual tread patterns were used, but there are now so many that such a chart would be impossible to keep current. It is very important that searchers be able to describe sole patterns and measurements on a radio. Sole patterns and measurements are covered in more detail in the chapter "Orientation to Tracking".

Personal information is critical for the ground searcher. Some information is obvious; was the person a smoker, and is this cigarette butt his brand? Is she familiar with the area and thus likely to take logical travel routes? Is the lost person a risk taker or is he meek and mild? How does he react to stress. How fit are they? Other personal information will be valuable primarily to the search planning team.

If the person travels regularly in the area, knowledge of **favourite destinations** will certainly be helpful, and these must be checked out early in the search.

In one case in northern Canada, a young man who was mentally challenged went missing in winter. He was known to like to visit friends across a five-kilometre wide lake. The frozen lake was checked for footprints on the route to this destination, and tracks were immediately found that led to his rescue.

PLS, LKP and IPP

It is obvious that we must know exactly where the person was last seen (**Point Last Seen [PLS]**) and the exact time he was seen there. The **expected or observed direction of travel** from that point is also important.

Sometimes the search subject has no PLS but was known to have driven his vehicle into a general area. When the vehicle is located it provides a strong clue similar to the PLS. It becomes the **Last Known Position (LKP)**, rather than the PLS. It differs from the PLS in that the subject was not actually seen there.

More recently, SAR Managers have begun to identify an **Initial Planning Point (IPP)**. This is the geographic reference point upon which the search planning process is based. It is the place and time that the search began and it does not change during the search. It may be the PLS, the LKP or an entirely different point.

All these points (IPP, PLS, LKP) are used to establish the probable search area.

Team Member Call-out

Once the SAR Manager has decided that team members are required, the call-out procedure is initiated. The call-out procedure for team members varies between different SAR Groups with many groups using pagers or a telephone fan out system to alert members that their assistance is required. The team page normally contains information regarding the type and location of the incident and the rendezvous point.

You now have to decide whether you can or cannot respond to the call. If you are at work and plan to leave, prior arrangements should have been made with your employer. There is no requirement that employers give SAR volunteers time off for search and rescue incidents. If you are at home, thought has to be given about your spouse, children or significant other. It is not heroic to always be out rescuing people you do not know while your personal life is neglected.

At this point you should also be thinking about how much time you have for this particular SAR incident. Do you have three hours or three days? This information must be passed on to the SAR Manager once you arrive at the rendezvous site. They will use this information when deciding your assignment. It hinders the search or rescue for a SAR member to be out on an extended assignment only to radio base and say that he has to leave before the assignment is complete.

Travelling to the Rendezvous Point

With the adrenaline coursing through our veins there is a tendency to race to the rendezvous site. However, as SAR volunteers in BC, we have no authority to drive above the speed limit, run red lights or have flashing lights on our vehicles. The time that is saved by ignoring traffic rules will not make a difference in most SAR incidents. We must look after the safety of ourselves and other people before trying to help the subject as best we can.

Signing In

Try to avoid driving to the SAR site in your own vehicle. When every SAR volunteer drives separately to the site a massive parking lot can be created in which vehicles cannot move and ambulances can not make it close to the scene. Go to the SAR hall or other rendezvous site and travel in the rescue truck or car pool.

Once at the rendezvous point or at the SAR site, find the person who is in charge of the sign-in sheet (check-in list) and sign-in. This is very important as the SAR Manager needs to know who is present to formulate a Incident Action Plan and to make sure everyone is accounted for at the end of the task. WCB coverage for operational tasks begins when the registered SAR volunteer is notified of the event (see PEP brochure on WCB, Insurance and Liability included with this manual). A check-in list form (ICS 211) is included at the end of this chapter. Many teams have developed their own sign-in sheets with the volunteers name, address and phone numbers already printed on the sheet. This way you only have to sign beside your name.

Do not bother the SAR Management Team with questions once you have signed in. They are trying to develop an Incident Action Plan and any distractions will slow the process. This is the time for you to check your gear, remove anything you do not need, fill water bottles or put on appropriate clothing. If you know the approximate area of the incident then spend time studying the map to become more familiar with the area.

SAR volunteers often rush to the rendezvous point only to wait to be given an assignment. **Do not get impatient!** The human resources that are available are used most effectively if there is a plan in place based on good information. Sending searchers out in the field with no plan is an ineffective and inefficient use of personnel.

Additional Resources

Provincial Emergency Program, Ministry of Attorney General. *Policy and Procedures Manual*. 1998

Provincial Emergency Program, Justice Institute of BC, Emergency Management Division. *Ground Search Team Leader Manual*. 1997

Provincial Emergency Program, Justice Institute of BC, Emergency Management Division. *Search and Rescue Management*. 1989

Brewer, Dave and Brewer, Gerry. *How to Organize a Search and/or Rescue (A Handy Reference Guide)*. New Westminster, BC, Justice Institute of BC, 1998.

Merry, Wayne. *Basic Ground Search and Rescue in Yukon Territory*. 1998.

Further references listed in the Bibliography.

Chapter Review

Please answer the following questions on a separate sheet of paper so that another student can use this manual. The answers to these questions are located at the end of the manual.

1. Why is a rapid response the most effective way to handle a search?
2. Who handles the initial call-out from the police?
3. What should you do when you reach the rendezvous point?
4. What is the difference between PLS and LKP?
5. Using the Relative Urgency Rating chart, determine the response level for the following subject:

A healthy, athletic, 42 year-old man, dressed in shorts and t-shirt has not returned from a hike in steep mountainous terrain in the Lower Mainland. He started hiking Saturday July 5 at 1 p.m. from the trailhead. It is now 11 a.m. on Sunday, July 6, there has been low clouds and drizzle since Saturday afternoon. The man was planning to hike up a steep trail that leads to a meadow. He is an experienced hiker but has not been to the area before. He has nothing with him. The surrounding area around the trail is riddled with steep cliffs that lead into gullies. There is no possibility of negligent or intentional harm. There is a history of hikers getting lost in the gully systems.

Answer: _____

Answer **True** or **False** to the following statements:

6. In BC, SAR volunteers may speed to a task as long as they have their emergency flashers on.
7. The Duty Officer is always a SAR Manager.
8. Searching at night is not effective.
9. Most people who are found dead on a search die before the end of the second day.
10. Employers must give time off to SAR volunteers.



Chapter 3 - Search Progression

Upon completion of this chapter, you will be able to:

- Explain how probabilities are used in planning searches.
- Describe how SAR Managers develop strategy and tactics.
- Outline what type of behaviour can and cannot be expected from the missing person.
- Summarize what type of information is given in a team assignment briefing.
- Explain why GSAR personnel search for clues not subjects.
- Be aware of sign.
- Isolate, mark and protect clues and area.
- Interview witnesses to obtain and record accurate information.
- Deal correctly with relatives and media.
- Outline the type of information that is collected during a team assignment review.
- Define mutual aid and explain its importance.
- Understand the importance of stabilizing a search subject before evacuation.
- Describe the four phases of a SAR operation.

Search Planning Procedure

Search team members should understand why they receive instructions for searching with specific techniques. If the assignments do not seem to make sense, searchers may lose confidence in their management team and search less enthusiastically.

For example, if a team gets instructions to sweep-search an area at a very wide separation that appears to give little chance of finding the subject, they may be puzzled and angry. For this reason, every searcher should understand at least the rudiments of search management, even though he has not been trained in probability calculation.

Working with Probabilities

Search planners work with probabilities. That's all they have to work with. If they had facts, there wouldn't be a search. The types of probabilities they work with are:

Probability of Area (POA)

Probability of Area (POA) is the probability, expressed as a percentage, that the subject is in a given search area or segment. It helps to determine which of several segments should be searched first. Each time a segment is searched unsuccessfully, its percentage goes down and that of other segments goes up. POA's may be applied to a route as well as an area.

Probability of Detection (POD)

Probability of Detection (POD) is also expressed as a percentage. This represents the probability that a search team on a given assignment will locate a clue or the subject. POD's of various sweep searches have been determined by experiment. For example, it has been calculated that a visual grid search for a subject dressed in bright clothing in thick forest should yield an 80% POD at a spacing of 41 metres, or a 40% POD at a spacing of 63 metres. A crude method of determining a POD for an area already searched is to ask the searchers, "If there were ten people in the area you searched, how many of them do you think you would have spotted?" If the answer is 7, then the estimated POD for that sweep was 70%.

Typical Search Procedure

When a search is initiated, an experienced SAR Manager and his or her team will probably follow a procedure something similar to what follows. They will:

- establish the urgency of the incident as we saw in Chapter 2
- alert all resources, including mutual aid and other agencies,
- dispatch his Initial Response (IR) resources as early as possible,
- map the search area, and segment it into sections small enough to be searched in one operational period,
- assign Probabilities of Area (POA) to the various segments,
- determine the Search Objectives for the first operational period, develop a Search Action Plan with appropriate strategies and tactics to meet those objectives,

- assign teams to search areas with the highest Probability of Area using search methods giving a high Probability of Detection (POD),
- calculate the combined POD's of the various search methods for each segment, and not
- do not consider any segment well searched until a cumulative POD is in excess of 80%,
- if an area is searched unsuccessfully, recalculate the shifting POA's for each area, change priorities, and assign teams accordingly,
- develop objectives and a search plan for the second operational period,
- deal with relatives and media throughout (usually through the RCMP),
- develop an evacuation plan for the time the subject is located, and
- plan for relief teams and shift changes.

The procedure above is simplified for the sake of brevity. It is a tremendous job, and team members must avoid distracting the management team. However, every bit of information you gather is important, and should be passed on through the Team Leader. Even if you saw something that *might* have been a clue, report it. A series of "possibles" becomes something probable. As in police work, SAR Managers tend to be suspicious of coincidences.

Lost Person Behaviour

Searchers need to have some knowledge about the expected behaviour of a lost person. Knowledge of this behaviour can help identify high probability locations for the victim. The SAR Manager can specify a general area in which a team should operate but only searchers in that area can fully evaluate its terrain and thereby direct their efforts most efficiently.

The original work on lost person behaviour was done in the US by William G. Syrotuck in his paper "Analysis of Lost Person Behaviour". The detailed statistical analyses he provides are essential reading for any SAR Manager, but go beyond the requirements of a GSAR team member. Only the most general observations are included here.

Irrational Behaviour

It is important to realize that missing persons will seldom behave rationally. When a person is lost, some degree of fear will always be present and may override the good judgement of an otherwise sensible person. The resulting panic may result in aimless running or frantic scrambling.

The failure to act sensibly will become more likely with the onset of cold and exhaustion. Few individuals build a fire or erect a shelter and the very few who do build shelters usually neglect to realize the camouflaging effect it may have on their location.

Most lost persons are poorly equipped. The few who are well-equipped seldom use the materials they have, often discarding useful items along the way. Clothing frequently suffers this fate. The fact that people will be looking for them is not recognized by many lost persons, and these people make no effort to make their presence known, even going so far as hiding from would-be rescuers.

The irrational behaviour just described means **definite conclusions can seldom be made** about what a missing person will and will not do and where he or she will be. Nevertheless, studies of lost person behaviour show some trends do exist.

Downhill

The great majority of lost persons (between 56% and 86%) head downhill from the Point Last Seen in mountainous terrain.

Distance

Dr. Ken Hill in Nova Scotia has done studies showing the distances that the various categories of lost persons are found. He has found that the median distance that lost persons are found ranges from 1 to 2.6 km from the point of origin.

This information can help the SAR Manager set high probability areas to be searched first. The highest probability areas being between 1 and 2.6 Km downhill from the PLS.

Lost Person Categories

Further generalities about specific categories of lost persons have been assembled. Some of the sample categories are Hunters, Children (1-3 years), Children (3-6 years), Children (6-12 years) Hikers, Elderly, Fishers, Climbers, Mentally Challenged, Trappers, Boaters, Snowmobilers and Depressed Persons.

Two examples of the type of information that are in the categories are:

Hikers

- rely on trails,
- have a destination in mind,
- get lost at forks in trail or if the trail is obscured by snow, rocks, etc,
- person who falls behind gets lost,
- tend to be easily detectable.

Children (3-6 years)

- very mobile,
- understand being lost and try to get home,
- become lost by following other children, animals or when just exploring,
- try to find a sleeping spot,
- may not respond to calls of searchers, have been warned about strangers.

SAR Managers use these general guidelines to plan the search but it must be remembered that these are only averages and will not always correctly predict where the lost person is located.

Direction

The probable direction of travel is a key factor in planning where to search.

People who become lost at a location such as a campground or picnic area are usually very young or very old. Look for something that would attract them to establish their initial direction of travel. People who become lost while following a trail often do so as a result of attempting some form of short cut. Poorly marked trails can also be a significant factor, particularly in areas honeycombed with old unmapped logging roads. People who become lost while away from major paths are typically hunters, or berry or mushroom pickers. The majority of such people have been found to locate a travel aid such as a creek or game trail and then follow it.

Detailed information about a missing person and their likely behaviour is essential in determining search strategy. It is one way to reduce the search area and increase the likelihood of success.

Team Briefings

Usually, the SAR Manager will brief the Team Leaders (GSTL or Rope Rescue Team Leader), and the team leader will brief the teams just before they go out. The information included in a team briefing is:

- Information about the situation (past and present),
- Subject profile,
- Clue considerations,
- The team's search area,
- Type of search pattern to be used,
- Weather forecasts,
- Potential hazards in the search area,
- Equipment required,
- Radio frequencies and whistle signals,
- How long it is expected to take.

Written briefing statements including maps and a picture of the subject may be handed out as these greatly increase the efficiency of the search.

Operational Periods

You must know exactly what is expected of you before you head out into the field. If there is any doubt, **now** is the time to bring it up. It should also be remembered that the Team Leader is in charge and has total authority and responsibility for the team.

Search Managers may use a Team Assignment Sheet (ICS 204, example included at the end of this chapter) to keep track of all the teams. This sheet may be handed out with the other briefing information given to GSAR team members.

Once the search is underway, the SAR Manager will determine the shifts or **Operational Periods** as they are called in SAR. An Operational Period may be anywhere from 6 to 12 hours, depending on circumstances. Field and management teams change shifts on this schedule.

Your field search assignment will usually be for 4 to 6 hours and you will likely be very tired when it is over. Searching is physically fatiguing and often emotionally draining too. Rest is vitally important for your efficiency and your safety. Get all you can between assignments – you may need all your endurance as the search continues. Do not be embarrassed to be seen resting and “refueling” between assignments. You must be fit to do a good job.

Clues and Sign

If a lost person is mobile, the search area will be increasing rapidly with time. Locating one person in such a large area would be an almost impossible task were it not for one fundamental fact. As the subject moves through an area they are leaving clues and sign and it becomes our challenge to find them.

Clues are objects or information that can be used to find a person’s location. Sign is the evidence of a person’s passage. Becoming clue aware and having a basic understanding of tracking are important skills for a GSAR Team Member to have.

Always remember that there are more clues than subjects and being able to identify these clues is critical to the success of the search. Therefore, we must not forget to **Search for Clues Not Subjects**.

A searcher who looks for clues is much more effective than many searchers looking for the missing person. Finding clues reduces the search area and can provide the basis for tactics used in the field.

Types of Clues

Clues can be broken down into a number of different categories such as people, physical, recorded and events.

People

Relatives, companions and witnesses can provide useful information on the subject. Information such as state of mind, equipment and clothing, health, stated destination, and experience is obtained by filling out the Missing Person Questionnaire at the beginning of the search. This information is important for planning how the search is going to proceed.

Physical Clues

Other people in the search area may or may not have seen the subject. Both positive sightings and negative sightings are useful clues. Correct interviewing procedures will be discussed later in this chapter.

Physical clues are tracks or sign that a subject leaves as they travel or items that have been dropped or abandoned. Sign can range from clearly visible tracks to slightly bruised or flattened foliage that is only visible to very experienced trackers.

There are many items that could be dropped by the lost person such as cigarette butts, clothing, or candy-bar wrappers. However, it takes practice to know what clues are important to the search and which are not. Do not make an immediate opinion about the value of a clue.

Recorded Clues

Recorded clues that can be useful are items such as notes left in cars about proposed travel plans, notes recorded in cabin journals, sign-in/sign-out forms at trail heads and summit registers.

Events

These more obvious and intentional clues include smoke from fires, flashing lights, whistle blasts and yelling for help. These clues are almost as good as finding the subject.

Clues and Their Preservation

Of vital importance in any search is the preservation of clues, particularly the subtle ones which are also the ones most easily destroyed. **If skilled trackers are immediately available they should be brought in before other search resources.** Vehicle tires can easily erase footprints on a logging road. The tracks of searchers on a trail can obliterate the victim's tracks, and searchers can easily create false clues by crashing through woods on their own.

Clearly, keeping all searchers at Base is not a solution, but **searchers must be very conscious of what they may be doing to clues and must be constantly searching for them.** Searchers who lack the necessary training to identify the most subtle clues should stay out of the areas where there seems a high probability of finding such clues. If Base Camp is near the point last seen, **searchers should stay close to their vehicles while waiting for orders,** rather than wandering around and possibly obliterating valuable clues.

Isolating and Marking Clues

When a clue is found on a search it has to be protected because it may be:

- Important for the search
- Important for a criminal investigation
- Used in court

Isolating and Marking Clues

To protect clues the following procedure should be followed:

- Limit access, mark and cordon off area.
- One person approaches and accesses the clue. Do not pick up or move unless absolutely necessary.
- Notify SAR base.
- Collect clue only if it will perish without protection from weather or if requested to by SAR base.
- If collecting a clue:
 - Map area where found
 - Bag it
 - Mark on bag
 - What the item appears to be
 - Task number, date, time, place
 - Note when, where and who you gave it to
- All members should keep notes remembering to:
 - Record only facts.
 - Keep notes continuous.
 - And notes should be in pen with errors marked with a single line (no erasures or obliterations). If conditions are such that only pencil can be used then use a pencil. Notes in pencil are better than no notes at all.

Effective Searching

During the search you must concentrate totally on what you are doing. Search is no place for small talk or horseplay. **Use every sense you have** to try to detect clues or the subject.

Put yourself in the subject's shoes. Ask, "if I were at this point, where might I have gone or what might I have done? What would I have seen, and how would it affect me? Given the weather at the time, what would I have done? What is the easiest travel path there?" However, also keep an open mind. Remember that lost subjects may act irrationally and go places you would not expect.

Sight is arguably the primary search sense, best used to find clues. There is only one subject, but there are thousands of clues.

Hearing is extremely important, especially early when the subject is responsive. One can hear much farther than she can see, especially in dense bush. A search subject may reply in a very faint voice, easily missed. Listen constantly, check any unexplained sound.

Radios must be used only for absolutely necessary communications. Too much traffic will hamper efficiency and distract searchers; too much radio noise may drown out the response of the subject.

Smell or scent frequently plays an important part. In one improbable case in the North, a helicopter crew smelled the woodsmoke of an unseen campfire, solving the search. Campfire smoke, cigarette smoke, and fuels can often be smelled far downwind. So, sadly, can decomposition.

Touch is often used by trackers to detect a depression under leaf cover or to determine if dirt is recently disturbed. It may be used to guess how old a campfire is or whether discarded clothing has been there long enough to become wet from dew.

No one has reported detecting a subject with his sense of taste yet, except on television.

When searching, **look for anything that is not natural**. Don't have a preconceived idea of what you are looking for. If you are looking for little things you will miss big ones; if looking for big ones you will miss little ones. Look ahead, to the side, back the way you came, even up into trees. Think, "If I were the subject, where would I have put my feet?" Look constantly for sign. A person cannot walk a kilometre without leaving one or two thousand signs behind her. Flag and report anything even vaguely suspicious.

Flagging Search Routes

Regardless of what type of active search you are doing, you must flag your route so that later searchers can tell where you have been, and so that your sign is not mistaken for that of the missing person. You can mark flagging tape with a felt pen in summer or a wax pencil or crayon in subzero temperatures. Show your team designation, date, time and bearing if you are following a compass course. It is not necessary to inscribe every flag in a continuous chain. Flagging tape has to be removed at the end of a search.

Urban Search Routes

As a GSAR team member you will eventually be involved in urban searches. Before proceeding to search any private property the permission of the homeowner or landowner must be obtained. Most people will allow you to search their property but any refusals have to be reported back to the Incident Command Post (SAR Base).

Negative Information is Information Too!

If you search an area carefully and find nothing, you have not failed! At least, you will have reduced the area in which the subject may be. It has been said, "the best way to find someone is to know where he is not!" You will have made a major contribution whether you find anything or not so long as you have searched carefully.

Interviewing Procedures

On occasion a less experienced member of a SAR group may find it necessary to do some interviewing. This often occurs when, in the course of searching a popular wilderness area, a person other than the missing person is encountered. Hikers or hunters would be the most likely examples. The searcher must be prepared to ask appropriate questions of such a person.

To begin with, the searcher should identify himself or herself and state in general terms only the purpose of the search. Precise details of the victim's appearance and clothing should not be stated. The person should then be asked to describe where he or she has been and to describe any people encountered in the area. If anyone has been observed, it is better to ask "what was the colour of the person's clothing?" rather than "was he wearing a red parka?" Avoid putting words in the mouth of the witness and do not ask leading questions.

Where specific details are volunteered, these details should be repeated back slowly to the witness in an attempt to assess the confidence of these observations. A time and location for any sighting is essential. If practical, an attempt should be made to get the witness to take the searcher to the exact spot.

The direction of travel is also vital, but again, the question should be asked "which way was he heading?" rather than "was he heading south?" If no one has been sighted, the possibility of other evidence should be explored. Again, care should be taken in phrasing the question. The evidence sought would include any of the more obvious clues previously discussed. Noting precise times and locations are vital.

If, at the end of the interview, the witness is willing to give his name and likely future whereabouts, this information should be obtained, but the issue should not be pressed if the witness seems unwilling (an unlikely situation). The searcher has no legal right to this information. If the witness has provided some especially useful information, it is useful to encourage them to go to the Incident Command Post (SAR Base) for a further interview with the SAR Manager and/or the police. It may be worthwhile, and practical, to accompany the witness back to base. It is quite likely that the witness will want to join the search.

If the witness is unwilling to go to base camp, or if there seems no need to do so, he or she should be given the names and telephone numbers of a person to contact. In addition, ensure that you have their telephone numbers. Finally, the witness should be thanked for their assistance.

Regardless of the responses of the witness, base must be informed of any encounter with a non-searcher in the area, and the precise details of any information obtained immediately relayed. Other teams must be aware of the person. The notes that were made must be carefully stored and delivered to base according to the instructions of the SAR Manager.

To summarize:

- **Treat the witness with the utmost courtesy**
- **avoid asking leading questions**
- **make careful note of any observations**
- **report any encounter**

Dealing with Relatives and the Media: State the Obvious

Relations with relatives and media are often extremely sensitive. Fortunately for SAR volunteers, these jobs are the responsibility of the police authority and should be referred to them whenever possible, especially if difficult questions are being asked, such as the subject's prospects for survival.

Frequently, relatives and friends of the subject want to participate in the search and you may not know who they are. They may be present at briefings. For this reason, use discretion in speaking to any unknown person. Beware of black humour in a crowd.

Field searchers are often approached by the media. As a GSAR team member you should refer reporters to the police or designated SAR Manager. Wild speculation can easily wind up in print or on TV and can be upsetting to friends and relatives or hinder a police investigation.

Do **not** say, "No comment!" This suggests that you have something to hide. A good rule, when pressed for a personal statement is to "**state the obvious**"; comments like, "It is really rough, exhausting country, but we have high hopes." Or, "The rain is making things difficult, but we are getting the job done anyway." Don't indicate your hopes are fading, even if they are.

Reviews (Debriefing)

Reviews are a critical part of the search effort. They are performed at two points – when a search team returns from its mission, and after the incident is over. The search team review will help to determine the subsequent strategy and tactics; the incident review will tell the organization how it can improve its efficiency on the next search.

Team Assignment Review (Debriefing)

This activity usually takes place after a tiring assignment, and it may be difficult to approach with enthusiasm. **However, every searcher should recognize that reviewing is the method of discovering the clues that may end the search, and that even if a team found nothing, that too is important information.** All searchers must recognize that reviewing is an absolutely critical part of the search.

In a small operation, the SAR Manager may conduct the team review. In a large operation, the Team Leader may review the team, and then be reviewed in turn by the Operations Chief or someone in the Plans and Records group.

If possible, each team member is reviewed individually, because in a group the stronger personalities may dominate and seemingly unimportant observations may be left unspoken. This should occur as soon as the team comes in and before they have a chance to talk with anyone else. Miscellaneous conversation tends to change what people recall and how importantly they regard it. Searchers should mention **all** of their observations, even if they seem insignificant.

The **exact area covered** will be determined and **mapped**, along with the **location of any clues**, regardless of how minor they seem. The **Probability of Detection** will be determined. This is the likelihood that the subject would have been found in the area. You may be asked, "If there were ten subjects in the area you searched, how many of them do you think would have been found?" The averaged answers should give something close to the POD – e.g. seven out of ten would equal 70%. Any area that could not be properly searched should be identified as well as any hazards in the search area.

Ideas and recommendations for future searching should be suggested at this time. A sample Team Assignment Debriefing Form is included at the end of this chapter.

Mutual Aid

Mutual Aid is the calling in of other SAR Groups to assist with a SAR incident. Usually, neighbouring SAR Groups are called first as they can most quickly respond. Mutual aid is now being activated earlier in a SAR operation as the chances of finding the subject alive are best during the initial hours and first couple of days.

Conducting mutual training exercises with neighbouring SAR groups greatly benefits everyone involved as the SAR volunteers get to know the skills and abilities of the other group's volunteers.

Finding the Subject

In a perfect world, the subject would be found in good shape and be able to walk out on his own. In the real world, he will often require stabilization and evacuation.

This underlines the importance of **all searchers having as much first aid training as possible**. Any searcher may be involved in the immediate care of the subject.

You don't do a search subject any favour if you let him die after he is found!

The four phases of a complete SAR operation are:

- **Locate**
- **Access**
- **Stabilize**
- **Transport (Evacuate)**

If there is any question as to whether the subject is stable and can be safely moved, he should be protected, given first aid, and kept warm and comfortable until more experienced medical help can be brought in. The rough handling involved in some rescues can kill a victim who is not stable.

What do we mean by "stable"?

There are two common types of instability. If a subject is badly injured, he may be in shock. His pulse and respiration are high and he may still be bleeding, either internally or externally. Dehydration, pain, and a degree of hypothermia may be contributing to the problem. The subjects' medical condition may worsen if they are roughly handled during transport. On the other hand, if medical care is brought in or first aid is provided without moving him, the subjects' vital signs may improve and he may then be safely moved.

The other type of instability is technically not instability at all. A severely hypothermic subject is quite stable as long as he is not roughly handled or does not try to exert himself. If either of these things happen, his heart may go into fibrillation and he may die. This subject must not be transported without careful forethought. Either he must be transported very gently or medical care should be brought in to attempt field re-warming which is a risky procedure. A good knowledge of hypothermia is mandatory for every search team member.

Once a subject is stable, and transportation is safe and will not cause him great pain, he may then be evacuated. Evacuations are covered more thoroughly in the Evacuation Chapter.

Additional Resources

Provincial Emergency Program, Ministry of Attorney General. *Policy and Procedures Manual*. 1998

Provincial Emergency Program, Justice Institute of BC, Emergency Management Division. *Ground Search Team Leader Manual*. 1997

Provincial Emergency Program, Justice Institute of BC, Emergency Management Division. *Search and Rescue Management*. 1989

Merry, Wayne. *Basic Ground Search and Rescue in Yukon Territory*. 1998.

Further references listed in the Bibliography.

Chapter Review

Please answer the following questions on a separate sheet of paper so that another student can use this manual. The answers to these questions are located at the end of the manual.

1. Describe where (in relation to the point last seen) you are most likely to find a missing person.
2. What type of information should be included in a team briefing statement?
3. A normal operational period for search teams is _____ to _____ hours, depending on circumstances.
4. A good rule for dealing with the press is to state _____, and refer them to the _____.
5. What is the purpose of team assignment reviews?
6. The four phases of a SAR operation are:
_____, _____,
_____, _____.
7. Define POD.

Answer **True** or **False** to the following statements:

8. A team review is not needed if no clues were found.
9. Search for subjects not clues.
10. Hypothermia victims should not be moved.
11. Lost person behaviour can always be predicted.
12. State the obvious when dealing with media.

Chapter 4 - Search Termination

Upon completion of this chapter, you will be able to:

- Describe search demobilization.
- Explain the importance of a rapid and thorough clean up at the end of a search.
- Understand the process of search suspension.
- Outline the procedure for dealing with a deceased search subject.
- Describe how personal expenses are handled by your SAR Group.
- Explain the importance of following sign-out procedures.
- Explain the value and availability of Critical Incident Stress debriefings.
- Participate effectively and objectively in field and incident reviews.

Introduction

There is no better feeling in the world than to return a lost child to its distraught parents.

In a National Park, a three year old girl was missing for three days and nights in thick forest, with the temperature dropping to near freezing at night. Everyone, including the parents, thought she was dead. She was found alive and well on the third day. There were about two hundred people present when she was handed to her mother. There wasn't a dry eye in the crowd.

That is the ideal ending although sooner would have been better. Unfortunately, there are always the "bad ones". In a certain number of cases, somewhere between 5% and 15%, depending on when and where in North America, the subject is not found. Some are never found while some are found dead at a later time.

A searcher must recognize that there will be times when he has done his utmost but it is not enough. Like any other emergency, service you do your best, and that is all that can be expected and all that you can expect from yourself. Sometimes there will be second-guessing criticism. Fortunately, there are enough "good ones" that we can usually feel pride at saving a life.

Demobilization

When field searchers hear that the search has ended, no matter what the reason, there is a tremendous tendency to drop everything and head for home, a good meal, a hot shower and a cold drink.

You must resist this urge!

A great deal of work remains to be done. All equipment must be turned in, sorted and returned to its owners. It must all be checked and repairs arranged if necessary. Some items, such as batteries, will have to be replaced. Fabric items and ropes that have become wet must be dried before storing, and equipment that is dirty will have to be cleaned. Base camp must be broken and left clean. It is not only the Equipment Officer's job to do this, it is every team members.

Flagging tape and string lines should be removed from the search area. Search packs must be checked and missing equipment replaced.

Everything must be done to ensure that the SAR Group will be ready to respond to another call-out. There have been many times in BC when a SAR Group has just completed one incident when they get called out to the next.

Often, equipment goes home in a searcher's pack. He fully intends to return it at the first opportunity, but it is still outstanding when the next search is called out. Some of it simply disappears, especially in massive searches with many unknown volunteers.

Sign-out

One of the most important responsibilities of a GSAR member is to check-in when returning from the field and **sign-out** when he goes home. The SAR Manager needs to be certain that no one has been “lost” or forgotten in the operation. Many SAR incidents have dragged on long after the subject was found because SAR volunteers had left without informing anyone and time was spent searching for them.

The Suspended Search

It is the responsibility of the Police to suspend a search. This is an incredibly difficult decision, considering that the missing person’s life may depend on it. A search will continue as long as there is a reasonable chance of survival, but the time may come when those chances are gone or the subject is thought not to be in the area.

A search is sometimes scaled down to a limited continuous search. This may occur when the subject is presumed to be deceased (or perhaps is not even in the area) but there is an interest in recovering the body. This may take the form of continued but limited air search, broadcasting of public service announcements or publication of advisories and bulletins, or conducting training exercises in the possible search area. Sometimes, this search will result in body recovery, especially in drownings or after snow melts.

There are countless examples of people surviving much longer than anyone would have thought possible. The Coast Guard suggests multiplying the realistic time estimated for survival by three. Even if it is quite certain the victim is dead, the search for the body may still continue, but it must be stressed that **the purpose of search and rescue is to save lives, not to retrieve bodies.**

Body Recovery

No person should be forced to miss work or put herself at any kind of risk in order to look for a dead body. However, SAR Groups may occasionally be asked by police to help locate persons that are presumed dead or to recover and transport bodies. Provided the recovery is not hazardous, GSAR members should be prepared to assist. Such help may relieve anxiety, provide closure for relatives, and be excellent public relations. In the end, it is a matter of personal choice.

Dealing with Death

There is always the possibility that the victim will be found dead. This immediately throws many first-aid trained persons into a panic because they have been told that they cannot declare death and must commence CPR and continue it until exhaustion. In fact, you should check with your local coroner on legalities. If there is the slightest doubt about whether the subject is dead then the subject should be treated as a live victim.

There are certain conditions that mimic death, and hypothermia is one of them. In profound hypothermia, respiration and heartbeat may be so slow and faint that it cannot be detected by a first aider and the body may be as cold, pale and rigid as death. If he is far from medical facilities, the subject must be protected from further heat loss and be rewarmed by **medical personnel** on the spot. CPR is usually not recommended as it may cause fibrillation and death. (Note: this is still debated in medical circles and advanced first aid is beyond the scope of this manual. SAR members should seek advanced training in hypothermia treatment).

The determination of death is aided by several signs. If the subject is beheaded, bloated, decomposed, or has been under water for an hour or more, there is no question. A person is probably dead if:

- there is not the slightest response to any sight, sound or painful stimulus,
- there is no pulse detectable at either wrist, neck or by placing an ear to the bared chest,
- there is no breathing detectable by sight, sound or touch, and
- the subject's pupils are mid-sized or larger, and do not respond to changes in light.

In time, three other indisputable signs will show:

- the body will cool, extremities first, even in a warm place,
- the body will stiffen (*rigor mortis*) several hours after death,
- a bruised, mottled appearance will appear on the parts of the body which are lowest, except on pressure points. This is caused by the blood settling.

If the subject is believed to be dead, the searcher's job is not over, as there will be a coroner's and possibly a police investigation. He must:

- ensure there are no hazards that threaten the search team,
- disturb the scene as little as possible,
- mark the access route used by the searchers to get to and to move away from the subject,
- rope off an area around the body and allow no disturbance by human or animal,
- notify search headquarters, being sure not to announce death or identify the subject on the radio except by prearranged code,
- record what he has seen and done,
- flag a route from the body to base or to a known point of reference if it is a hard to find area (do this only if enough SAR personnel are available), and
- keep watch until Police or Coroner arrives.

SAR Task Reports

Staying with the deceased until the authorities arrive is a job that someone has to do, like it or not, unless it would be hazardous to the rescuer. Under some situations neither the coroner nor the police will be able to view the body. In these situations they may request that you take notes or photograph the area and package and transport the body.

After every SAR task the SAR Manager has to write-up a SAR Task Report to be sent to PEP. The reports are used to inform PEP about details of the task and to claim expenses which occurred on the task back from PEP. As a GSAR team member you will not be filling out one of these reports but the SAR Manager will want some information from you.

Personal Expense Claims

In BC, PEP covers some personal costs incurred when a volunteer responds to a SAR Task. Costs such as meals, mileage and personal equipment replacement or repair are ordinarily covered by PEP. Expense claim requests are turned in with the Task Report and PEP either approves or rejects the claim. The general procedures for expense claims are as follows:

Once a SAR Task is complete the volunteer should immediately fill out an Expense Claim Form (ICS 304 is shown at the end of this chapter although some teams use their own forms), and hand this in to the SAR Manager. This informs the SAR Manager of personal meals, mileage and the approximate cost of any pieces of personal equipment that were damaged or lost on the task. These expense requests are included with the SAR Task Report. **Do not wait for 2 or 3 weeks after the task to turn in you expense claim.** If you turn it in after the Task Report has been sent to PEP you will not get reimbursed.

PEP will then approve or reject the expense claim. Once approved, the equipment can be repaired or replaced. The original receipts go to the SAR Manager who forwards them to PEP for reimbursement. If you decide to repair or replace equipment before PEP approves the request, you must realize that they may reject the request and you will have to cover the cost.

Critical Incident Stress Debriefing

Stress is any normal reaction to an abnormal event. Critical Incident stress is the overwhelming of a person's normal coping abilities due to an intense or extreme event. Many SAR events, such as the death of a child, a multiple casualty incident, threat to your life or a situation where the victim is known, can cause critical incident stress.

Incident Reviews (Debriefs)

As a SAR volunteer you should be aware of how you and your fellow volunteers are handling critical incident stress. Each person will react differently to a critical incident. Anyone whose behaviour has changed should be approached and asked if they are having problems as a result of the incident. Some relief may occur simply by rescuers discussing their feelings frankly among themselves. But no searcher should hesitate to ask for professional counselling. Critical Incident Stress Debriefing (CISD) can be arranged through the SAR Manager.

It should also be recognized that members who were not present at the incident may also be affected. They may be experiencing problems because they were not able to help and now feel responsible for the outcome.

In addition, the family and close friends of SAR volunteers may be experiencing problems. The difficulties that the SAR volunteer is experiencing may affect the family or friend or the family or friend may experience anxiety when the volunteer is out on potentially dangerous incidents.

Reviews (formerly called critique, postmortem or debrief) should be conducted for every SAR incident. Reviews can be conducted at the end of each day or at the end of each operational period as the incident progresses and a formal incident review should be conducted at the completion of the SAR incident.

It is also highly desirable to have a quick field review at the Command Post before demobilizing. This will help to ensure that all personnel and equipment are accounted for, and will bring cooperating agencies together briefly before the formal incident review.

Most formal incident reviews occur a few days after the search but may occur several weeks after the search. These are fairly formal affairs involving SAR members, PEP, the police, other SAR Managers and other mutual aid personnel.

The two basic objectives to be achieved by the review:

- To provide the Police, SAR members, PEP, other mutual aid personnel and other SAR Managers with a chronological, straightforward review of all activities that have taken place up to the time of the review.
- to discover operational opportunities which will allow the SAR team(s), other responding mutual aid agencies and individual members to provide a more effective and efficient SAR response.

The review process must include the displaying of three basic questions that must be asked during or after any phase or conclusion of any SAR operation.

- Was the SAR operation a success?
- Did anything unusual happen that helped or hindered the SAR operation?
- What can we learn from this SAR operation?

A common problem with any review is that if it is not carefully structured it tends to degenerate into a session where participants complain about each others' performance and conduct a thinly disguised witch hunt to place the blame for an imperfect operation. Some participants come in feeling aggressive, defensive or both.

People or groups, who know things did not go well or who got negative press, feel defensive and emotions defeat the purpose of the meeting. **Everyone involved should recognize that no operation is perfect;** that every last one can be improved. The object is to identify problems and determine solutions, and to assign definite responsibility for making the changes. Look at a review as an opportunity to improve. Of course there were problems! There always are.

Incident reviews usually start with one or more of the SAR Managers describing what was done. After that, the group tries to determine how it can be done better next time. Here is where confrontations start. A good way to ensure reviews remain constructive and objective is to insist that everyone use the format:

- Observation
- Comment
- Suggestion
- Action
- Responsibility for Action
- Date Action to be Taken

What do these mean? Here's an example. A member of the review, using this format, says:

Observation:

"I noticed that when new people came into the Command Post, nobody knew who was in charge or what each person was doing."

Comment:

"There were no name tags or signing to identify people, and we spent a lot of time explaining who was doing what. Also, the volunteers who didn't know who the SAR Manager was didn't pay any attention to her."

Suggestion:

"Name tags or arm bands should be provided for quick identification."

Action:

"Prepare identifying tags for each member of an organization, and place them in the field kit. Wearing the tags should be included in the standard operational procedures (SOP's)."

Responsibility for Action:

(usually volunteered or assigned by a senior agency representative)
SAR group Equipment Officer and Secretary.

Date Action to be Taken:

To be done by next meeting.

If the subject is willing to participate, he can be a tremendous help. He can explain his thinking and behaviour which may be of help in future searches. However, many subjects feel as though they will be "on trial" and are unwilling to attend.

With the right attitude of participants and a good facilitator, the incident review can be an extremely useful way for SAR Groups to improve the effectiveness and efficiency of their SAR response.

Additional Resources

Brewer, Dave. *Standardized Review Process*. SAR Reference Memo, Provincial Emergency Program. Victoria, BC, 1998.

Provincial Emergency Program, Ministry of Attorney General. *Policy and Procedures Manual*. 1998

Provincial Emergency Program, Justice Institute of BC, Emergency Management Division. *Ground Search Team Leader Manual*. 1997

Provincial Emergency Program, Justice Institute of BC, Emergency Management Division. *Search and Rescue Management*. 1989

Merry, Wayne. *Basic Ground Search and Rescue in Yukon Territory*. 1998.

Further references listed in the Bibliography.

Chapter Review

Please answer the following questions on a separate sheet of paper so that another student can use this manual. The answers to these questions are located at the end of the manual.

1. What is search demobilization?
2. Describe two problems that may be encountered in search demobilization.
3. What is the purpose of an incident review?
4. Outline the format that ensures that the review remains constructive.
5. The _____ has the authority to suspend a search.
6. Why might a search be suspended?
7. Explain how a SAR member would claim for personal expenses incurred on a task.

Answer **True** or **False** to the following statements:

8. Critical Incident Stress may affect a SAR volunteer not at the SAR incident.
9. It is best for SAR volunteers to move a deceased body to a more accessible spot for the coroner to view.
10. SAR volunteers are occasionally asked to assist in body recovery.
11. It is best to get a good night's sleep before cleaning up gear.
12. Reviews are only held at the end of an incident.

Chapter 5 - Maps

Upon completion of this chapter, you will be able to:

- Differentiate between types of maps used in SAR.
- Identify a map by name and map sheet number.
- Use the map scale to convert back and forth between map distances and actual distances.
- Use the following plotting methods or grid systems:
 - Geographic Coordinate System – Latitude/Longitude.
Give the latitude and longitude of a point on the map and locate a point if given the latitude and longitude.
 - UTM (Universal Transverse Mercator System) 6 figure grid coordinates.
Give the 6-figure grid coordinate of a point on the map and locate a point given the 6-figure grid coordinate.
- Read and interpret map legend.
- Identify the five main feature categories on a map, i.e.:
 - Cultural Features
 - Water
 - Relief
 - Vegetation
 - Toponymy (Names)
- Use contour lines to recognize important features and to obtain an approximate picture of the topography of an area.
- Handle a map in such a way as to maximize its lifetime.

Map Types

The ability to use a map effectively is an essential skill for any member of a SAR team. Such use of maps requires of course, that suitable maps be available. Several types of maps may be used in a search.

Topographic Maps

Some of the most commonly used maps are the government topographic map produced by Natural Resources Canada. They are available in two scales 1:250 000 and 1:50 000. The 1:50 000 is the more useful of these two maps for SAR.

Topographic maps are distinctive in that they include not only the usual information about roads and waterways carried by most maps, but also precise details about the shape (topography) of the land. Maps of this type are available for all areas in Canada and may be obtained in many different scales (to be discussed in the next section).

The advantages of topographic maps are the wealth of information they provide and the precision with which one can describe a point on the map. One disadvantage is that they are usually updated no more frequently than every 10 years, and information about man-made features, such as logging roads, can be quite inaccurate or incomplete. The date of last updating is normally found in the bottom left-hand margin. Figure 5.1a illustrates an area on a government topographic map. A second disadvantage is that the most detailed maps of most areas are on the scale of 1:50:000 (2 cm = 1 km). A ground search would normally correspond to a very small section of such a map.

Problems with obtaining the most up to date information on logging and other wilderness roads can often be solved by obtaining a map from the logging company active in the area. Figure 5.1b illustrates a logging company map of the same area as illustrated in Figure 5.1a. These maps, if available, are not usually topographic and may make the problem of getting from point A to point B look much easier than it really is. These maps seldom feature a location grid and are likely to be to a scale making distance measurement complicated. Nevertheless, used in conjunction with the appropriate topographic map, they can be an invaluable search aid. The Ministry of Forests may also be a good source of up to date maps and the local office should be consulted in this regard.

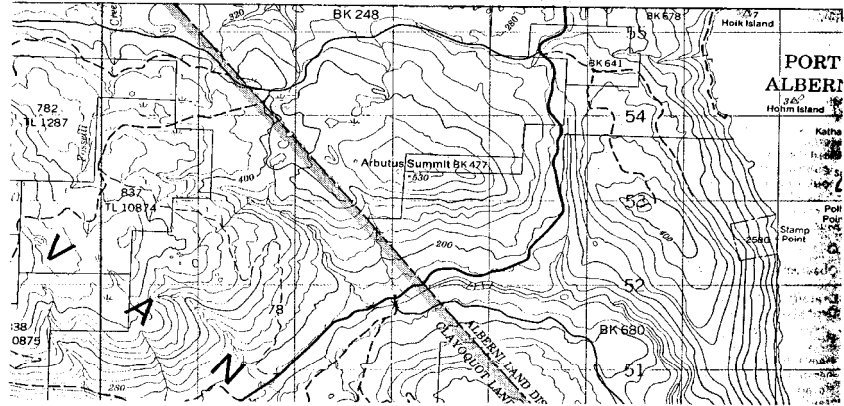

a) 1:50,000 map of area West of Port Alberni

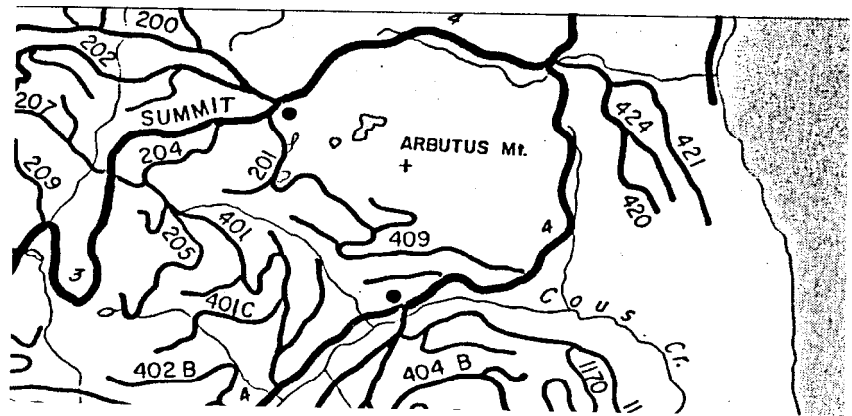

(b) MacMillan Bloedel map of same area

A COMPARISON OF A GOVERNMENT TOPOGRAPHIC MAP AND A LOGGING COMPANY MAP OF THE SAME AREA.

Figure 5.1 (a & b) Topographic and Logging Company Maps

TRIM Maps

The BC government TRIM format resource mapping project produced a series of maps in 1:20 000 scale. A sample TRIM map is shown in Figure 5.2. TRIM topographical maps are available for most areas of BC. If possible, a "mylar" plot should be obtained. This can be periodically updated as to roads, hazards, trails and landmarks by the SAR team. Dry prints can then be run at any municipal or Forest Service office. If a map is then used during a search, it can simply be kept with the SAR task report records.

With the rapid advancement in GIS (Geographic Information Systems) technology over the past few years, some municipal and provincial government offices may be able to plot coloured TRIM maps with UTM grid coordinates.

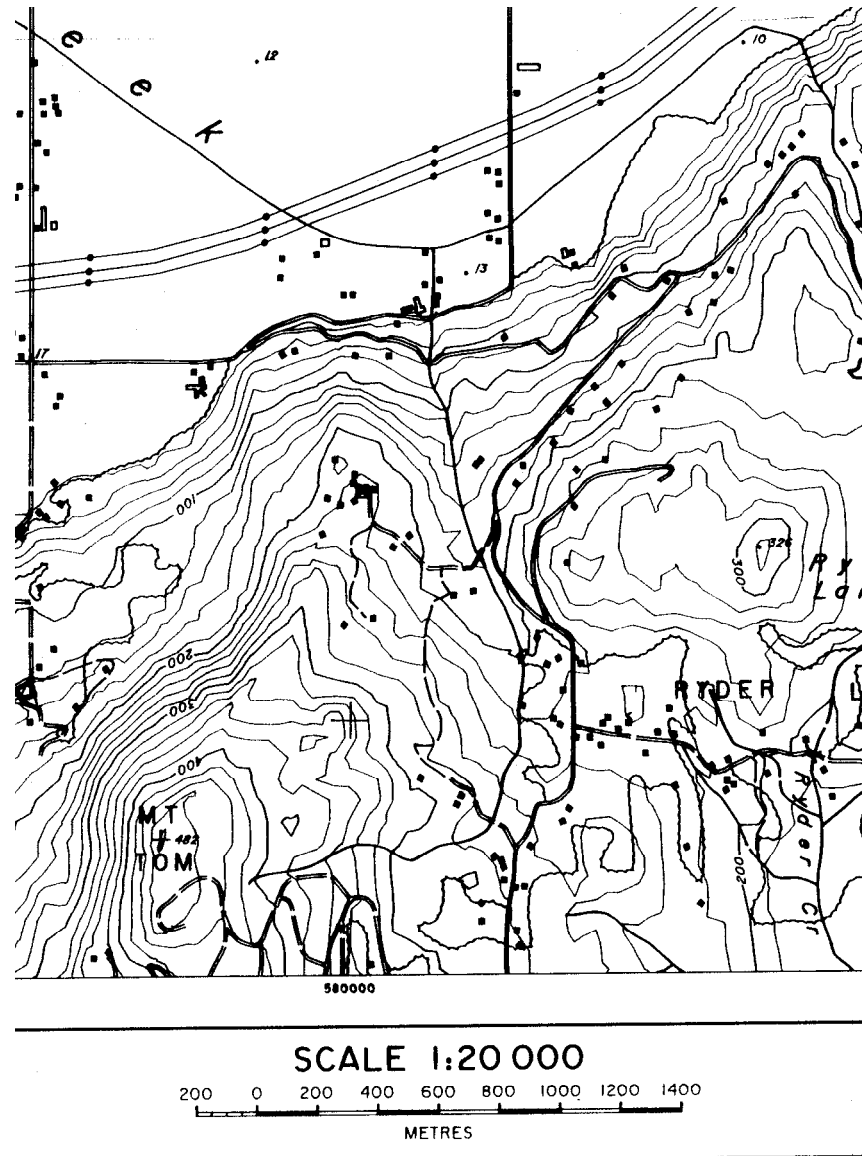

Figure 5.2 TRIM Map

Search Status Map

Obtaining a map on a scale suitable for a modest ground search may require the construction of a sketch map by the SAR Manager or other skilled person. It is likely that a ground searcher will be given such a map when heading into the field. These maps can have as much detail as the person preparing it can provide, but obviously, the preparation of such maps is very time-consuming and may not be possible in the early stages of a search. Photocopiers with enlargement capabilities are now in common use, and may be a valuable resource for quick alteration of map scales.

Orthophotos

Orthophotos are photographs in which objects on the ground are shown in their true positions. Therefore, you can use an orthophoto as a map from which you can make direct measurements. Traditional air photos have image displacement which make it difficult to make direct measurements.

Other data such as contour lines can be superimposed on the orthophoto which makes them very useful for SAR operations. Forestry orthophotos are available in the scale of 1:15 000 with contour intervals of 20 m and they are upgraded every four years. When storing, orthophotos should be rolled with the photo facing the inside of the roll. This will ensure that the photo does not fade.

Orthophotos may be available to SAR Groups from the local Ministry of Forestry office, local forest companies or municipal office.



Figure 5.3 Orthophoto for Whistler Spearhead Area. Published by Beta Digital Mapping.

Air Photos

Air photos can be extremely useful for search planners, however, it can be quite expensive to get a set of these for a SAR team's area and as mentioned earlier they have image displacement. They can be obtained at forestry offices, forest companies, and municipalities.

Other Map Sources

Another good source for obtaining maps may be the local tourist bureau. Often forest company maps are available through such outlets. Also, a series of topographic maps of major BC recreational areas is now available and is likely obtainable through the tourist bureau and outdoor stores. If not, these 1 cm = 1 km maps may be obtained through:

Outdoor Recreational Council of B.C.
Suite 334, 1367 West Broadway
Vancouver, BC
V6H 4A9
Phone: (604) 737-3058

In the discussion of maps that follows, the government topographic map will be the basis for discussion. Local knowledge of roads and trails is absolutely invaluable. Logging roads wash out and become impassable, trails become overgrown and new trails are made. Time spent investigating the local area is excellent preparation for future SAR tasks.

How Map Sheets are Defined

Topographic maps, produced by Natural Resources Canada, conform to the National Topographic System (NTS) of Canada. They are available in two standard scales, 1:50 000 and 1:250 000. The area covered by a given map sheet is determined by its latitude and longitude. Maps can be identified with a map number and a common map name. Because of the standard NTS numbering system, knowing the map number allows you to quickly identify adjacent maps. The adjacent map sheets are identified in a legend on the edge of each map.

The 1:250 000 scale maps are identified by a combination of numbers and letters, A through P (e.g. 92J). See Figure 5.23 at the end of this chapter for the index map for the 1:250 000 maps.

The 1:250 000 blocks are divided into sixteen segments (1 to 16), forming blocks used for 1:50 000 scale mapping (e.g. 92J/ 2 identifies Whistler, BC, 92J/2 is the map number and Whistler is the common map name).

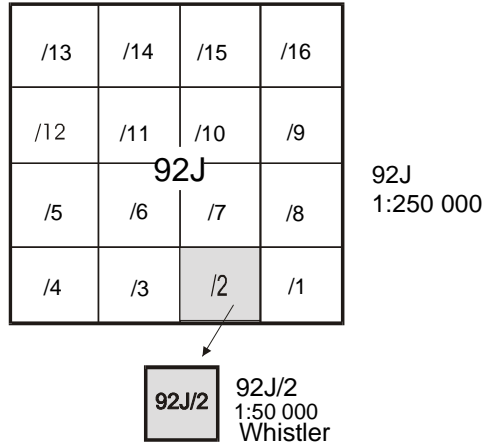

Figure 5.4 How 1:50 000 Map Sheets are Defined

An index map for the 1:50 000 maps is shown in figure 5.24

Trim Maps

The 1:250 000 blocks are also broken into smaller segments to identify TRIM maps. However, instead of 16 segments as is done for the 1:50 000 scale maps there are 100 segments to each block for the 1:20 000.

Note: TRIM maps and other large scale maps (1:5 000 and 1:10 000) are not in NTS like the 1:50 000 and 1:250 000 federal topo maps but conform to the BC Geographic System (BCGS). This will become important when describing grid coordinates.

**BC GEOGRAPHIC NUMBERING SYSTEM
MAPPING SCALES 1:20 000**

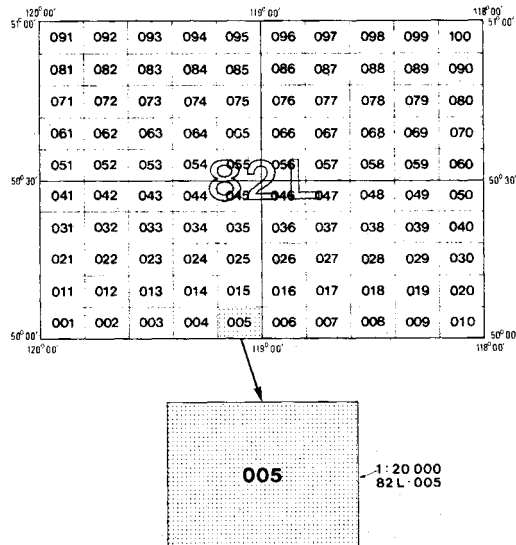

Figure 5.5 How Trim Maps are Defined (82 L is the 1:250 000 Map)

Municipal Maps

Each 1:20 000 map is further divided into 4 – 1:10 000 sheets, each of which can be divided into 4 – 1:5 000 sheets.

In BC, government topographic maps including TRIM maps are available from agents in most major centres, or from MAPS BC.

1:5 000 and 1:10 000 are the standard scales for most BC government sponsored municipal mapping. Local governments may have these maps in planimetric, topo/planimetric combinations or, in some areas, as digital orthophotos. Either of these is an excellent scale for either an urban search or detailed search status map.

Scale

A map's "scale" refers to the relationship between distance on a map and the corresponding distance on the ground. One commonly used scale in SAR work is 1:50 000 (one to fifty thousand). At this scale, one unit of measure on the map represents 50 000 equivalent units of measure on the ground.

Therefore, 1 cm on the map represents 50 000 cm on the ground (50 000 cm = 500 m = 0.5 km).

Two (2) cm on the map = 100 000 cm = 1000m = 1 km on the ground. The 1:50 000 notation also means 1 inch = 50 000 inches (about 0.8 miles) and 1 mm = 50 000 mm = 50 m.

The scale of TRIM maps is 1:20,000 which is very useful for SAR operations. In this scale, 1 cm on the map = 20 000 cm = 200 m = 0.2 km on the ground. An alternative if these maps are not available is to photographically enlarge the 1:50 000 map to produce 4 - 1:20 000 sheets.

Other scales on government maps are:

1:250 000	1 cm = 250 000 cm = 2.5 km	(4 mm = 1 km)
1:125 000	1 cm = 125 000 cm = 1.25 km	(8 mm = 1 km)
1:100 000	1 cm = 100 000 cm = 1.0 km	(1 cm = 1 km)

Sketch maps of a search area would likely have a scale of either:

1:10 000	1 cm = 10 000 cm = 100 m	(10 cm = 1 km) or
1:5 000	1 cm = 5 000 cm = 50 m	(20 cm = 1 km)

Recent advancements in digital orthophoto technology has enabled the production of "orthophoto maps" at almost any scale and combination of information.

Significance of Scale

Small scale maps (e.g. 1:250 000) cover large areas in less detail, whereas medium scale maps (e.g. 1:50 000) cover smaller areas in greater detail. Large scale maps (1:10 000) cover the smallest area with the most detail.

Figure 5.6 and 5.7 will give an appreciation of the significance of scale. Figure 5.6 illustrates the actual ground area that would be covered by a map 80 cm x 60 cm in different scales. Figure 5.7 shows the same area of land as portrayed on maps of 2 different scales.

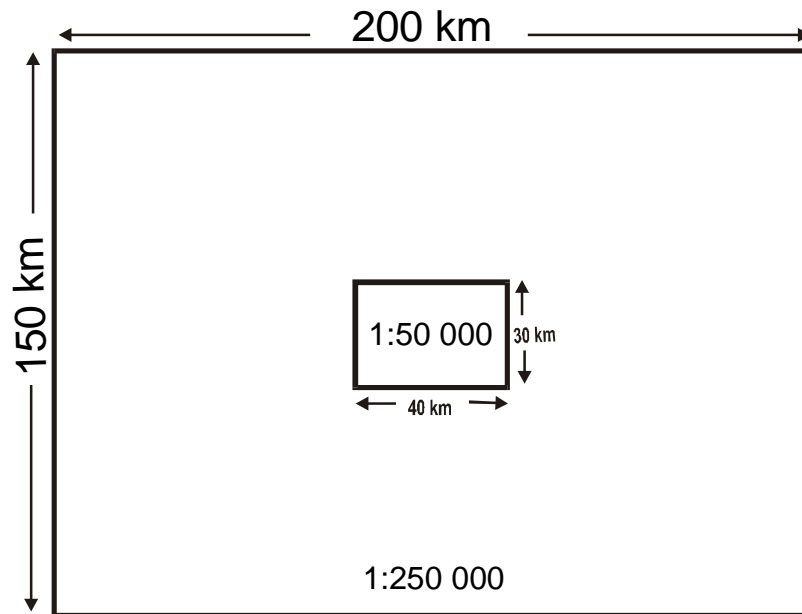
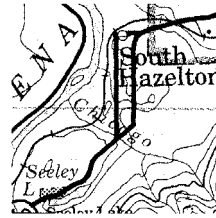
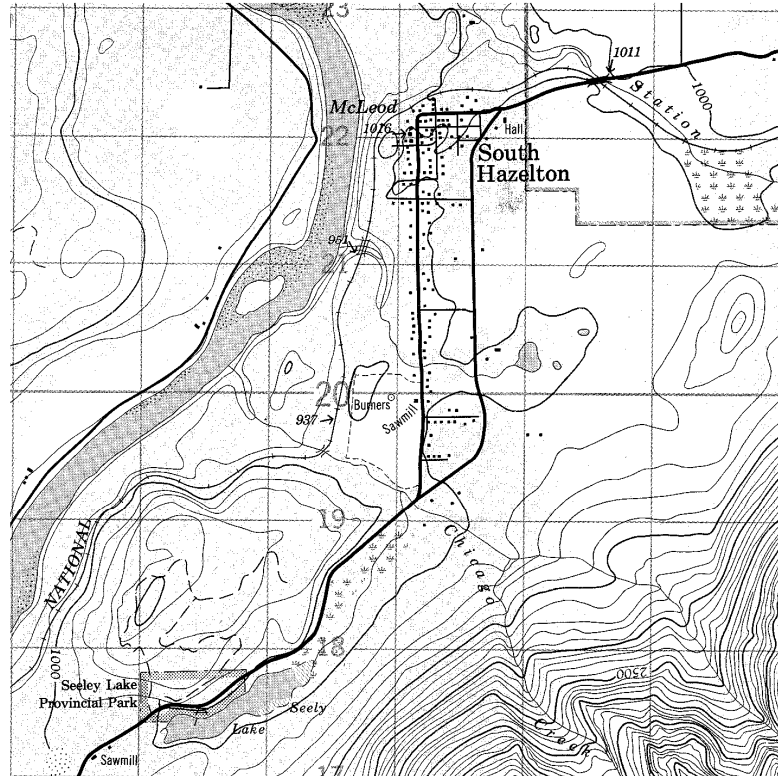

Figure 5.6

One 80 cm X 60 cm 1:250 000 map covers an area of 200 Km X 150 Km
 One 80 cm X 60 cm 1:50 000 map covers an area of 40 Km X 30 Km



1:250 000



1:50 000

Figure 5.7 Identical Sections of the Skeena Crossing Map In 2 different scales.

Distance Measurements

Several techniques are available for measuring the distance between points on a map. For people proficient in mental arithmetic, converting from units on the map to units in the field can be done in their head. However, many rescuers find it difficult to perform such calculations, particularly in the field, and some simpler approaches are available.

One approach that may be used is to compare the map distance with the scale at the bottom of the map. By measuring the distance with a ruler and then measuring the same distance along the scale, a distance can be determined.

However, in the absence of a ruler, the 2 points may simply be marked on the edge of a piece of paper which can then be laid along the scale. An example of this approach is illustrated in Figure 5.8. Note how the section of the scale divided into 100 m steps is used.

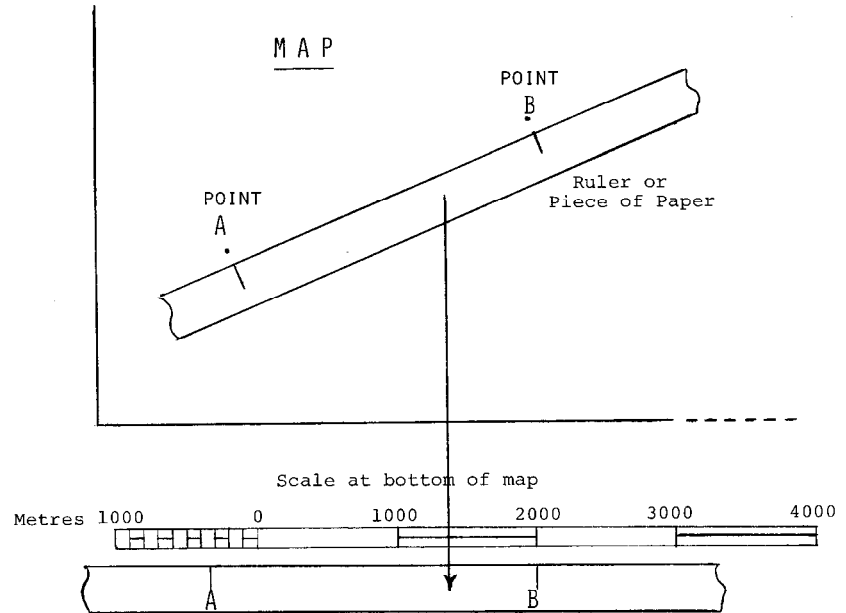

Actual distance between A and B is 2330m.

Figure 5.8 Simplified Distance Measurement

The most efficient approach to distance measurement involves the use of some form of romer. This device is simply a ruler that reads actual distance (km) rather than map distance (cm). A different romer is therefore needed for each map scale. However, the high frequency of use of 1:50 000 maps in SAR makes a romer for this scale an invaluable tool for any rescuer. A sample of a very basic romer for 1:50 000 maps is illustrated in Figure 5.9.

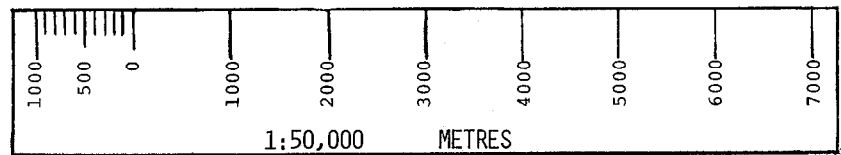

SAMPLE ROMER FOR 1:50,000 MAPS

Figure 5.9 Sample Romer For 1:50 000 Maps (not to scale)

To measure a curved route such as a trail use something flexible such as string or wire. The string or wire can be placed with one end on the starting point of the route and then curved along to follow the route on the map. Use your thumb to mark the finishing point of the route. The string is straightened and placed against the scale without stretching and the distance determined.

A set of dividers may also be used to measure between two points. The dividers are opened so that each arm is set on one of the points. The opened dividers are moved to the scale to determine the exact distance. For measurements other than straight-line distances, the dividers may be set on the scale to a very short distance (e.g. 1 km or even less), and then “walked” along the course on the map.

Also available are wheeled map measuring devices which are rolled across the route on the map and displays the actual ground distance. This only works well if the map is totally flat with no folds which seldom happens in the field.

The UTM grid lines can also be used to roughly estimate distance. The UTM grid lines on a 1:50 000 map are 1 km apart and therefore the number of grid squares that a route crosses can be counted and a distance calculated.

NOTE: Remember that elevation change is not taken into account when measuring a distance between two objects on a map. Unless the terrain between the two objects is flat the actual distance that has to be covered will be longer due to the slope. Also, the time required to travel a distance will vary depending on the elevation change.

Describing a Point on a Map

The two most common methods of describing locations on a map are UTM grid and latitude and longitude. Both use the crossing of a north-south line with an east-west line to describe a location. UTM grid co-ordinates utilize the crossing of a north-south grid line and an east-west grid line to describe a position. Latitude and longitude co-ordinates also use a grid, but with the exception of the widely-spaced lines of latitude and longitude on a map, there is no actual lines to work from.

It should be noted that some maps (older maps) are based on North American Datum 1927 (NAD27) while most maps since 1990 are based on North American Datum 1983 (NAD83). What this means to the map user is that for the same point on the ground, the grid coordinates can move up to several hundred meters when converting between the two types of maps.

It is therefore important to state which datum was used on your map when giving grid coordinates especially if there is a mix of old and new maps being used on a search. The datum that was used is stated on the map usually near the metric conversions for elevation or at the bottom of the map.

UTM Grid

On most topographic maps, and some other maps as well, a grid is superimposed to aid in describing the location of particular points. This grid is called the UTM grid (Universal Transverse Mercator). The lines on the rectangular grid run approximately North-South (North being at the top of the map) and East-West. A point on the map may be described by its position relative to the grid.

If you look at the edge of a 1:50 000 map you will see that each grid line is given a 2 digit number. These numbers also appear at one or two places across the face of the map.

On 1:50 000 maps, the grid lines have a 1 km ground spacing and are separated by 2 cm on the actual map. The grid spacing is 2 km on some 1:100 000 maps and larger still on large-scale maps.

For example, a church might be located as shown in Figure 5.10. In the horizontal direction it is about 3/10 of the way from 15 to 16. In the vertical direction it is about 8/10 of the way from 73 to 74. Its' grid co-ordinates would thus be given as **153 738**.

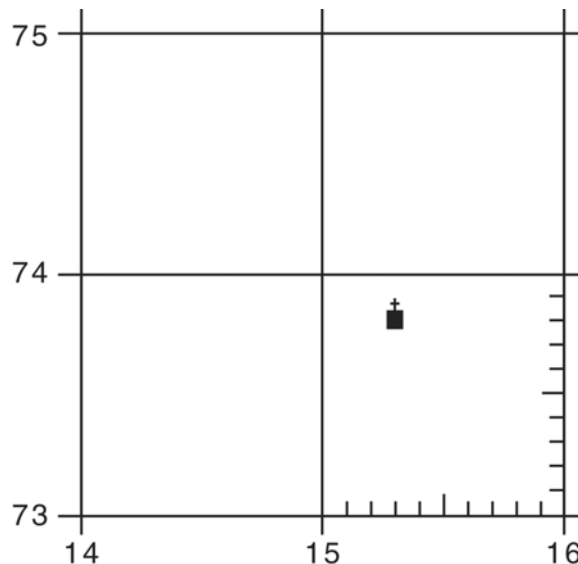

Figure 5.10a Grid coordinates of Church 153 738

Note that the "easting" co-ordinate is always given first and the "northing" co-ordinate second. A useful phrase for remembering this order is "**in the door and up the stairs**" or "**read right up**" meaning horizontal first, then vertical.

On declination adjustable compasses used by SAR Groups there are two romers on the transparent base plate that will enable you to determine tenths more accurately. These are usually for map scales of 1:25 000 and 1:50 000. Figure 5.10b demonstrates the use of a romer on a compass base for determining UTM grid coordinates.

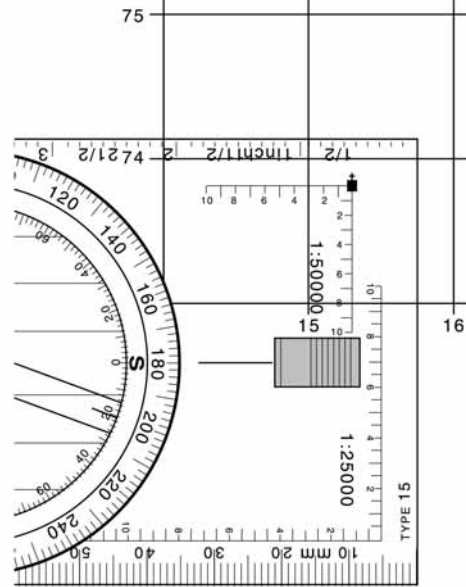

Figure 5.10b Use of the Romer on a Compass Base for Determining UTM Grid Coordinates 153 738

Figure 5.11 gives examples of the grid co-ordinates of 5 points on a section of map.

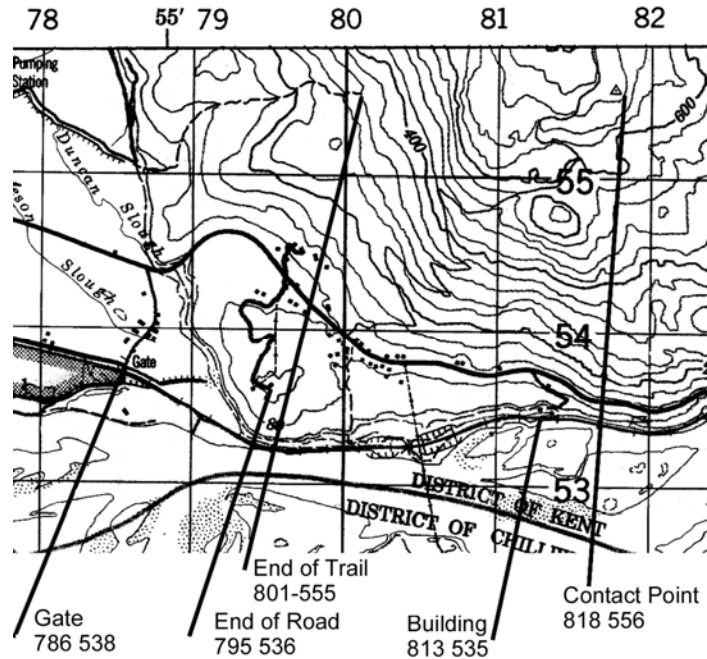

Figure 5.11 Sample Grid Coordinates

In the case of a very large search area (more than 100 km across), two points with 100 km separation could have the same grid co-ordinates. To avoid confusion, the name of the map sheet on which the co-ordinates are given should be added.

On a 1:50 000 or 1:25 000 map, one tenth of a grid division is 100 m. thus the six figure grid co-ordinates describe a position within 100 m. If a ruler is available, fractions of a division may be specified in hundredths rather than just tenths and eight figure grid co-ordinates may be used, describing positions within 10 m, however, six figure co-ordinates are satisfactory for most purposes.

In quoting grid co-ordinates, a line marked as 07 should be given as "zero-seven" rather than just "seven", and if a point were right on this line it would be given as 070 "zero- seven-zero".

Trim maps (1:20 000) may or may not have UTM grid lines across the map. If they do not have grid lines they will have the grid numbers positioned along the edge of the map. Remember to mention if you are using a TRIM map to describe a position if others are using the federal topos.

In case you forget, there is an explanation of the UTM grid system in blue on the right side of most maps that have the grid.

A GPS unit can also give your location in UTM Grid Coordinates, however, it will give a 17 character number. See the GPS section in Chapter 7 – Map and Compass for an explanation.

Latitude and Longitude

When a searcher in the field has to communicate directly with an aircraft, latitude and longitude has to be used. Pilots deal with latitude and longitude not UTM grid co-ordinates. Every point on the earth's surface has a unique latitude and longitude while different points 100 km apart may have the same UTM grid reference.

On a globe of the world, you will see a wide-spaced grid of lines of latitude and longitude. Lines (or parallels) of latitude run around the world in an east-west direction, and are parallel. They do not converge anywhere. Lines of longitude run from pole to pole. Unlike latitude, they converge at the poles, so that there is less space between them as you get farther north or south.

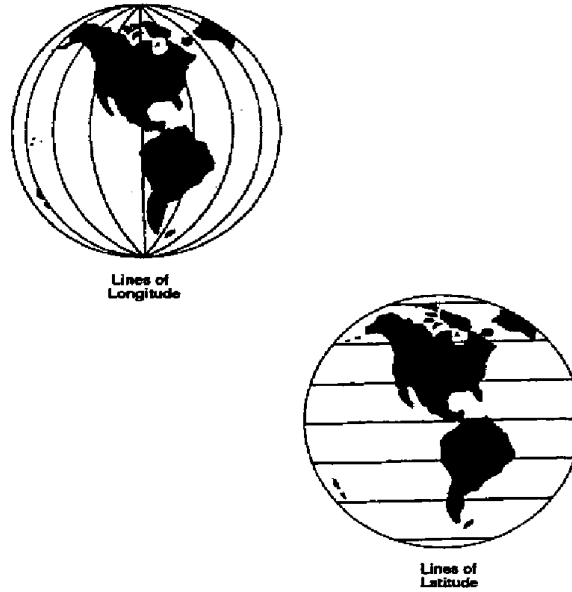
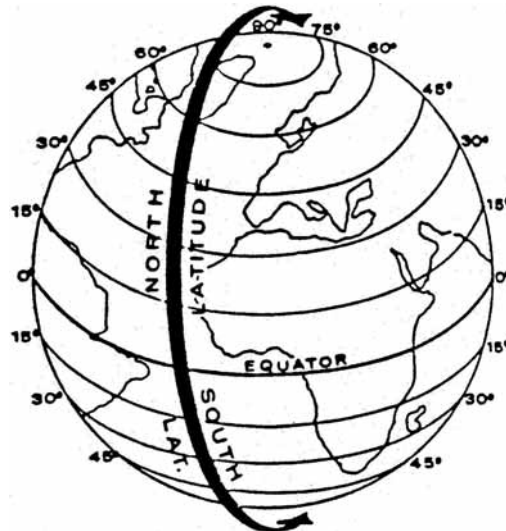

Figure 5.12 Meridians of Longitude and Parallels of Latitude

Latitude

The lines of latitude at the equator start at 0°. For locations in BC, the lines of latitude vary between 48° N (Southern Vancouver Island) and 60° N (Yukon border). The N for North is added to distinguish between points at the same angle below the equator. A degree of latitude always corresponds to about 110 km. Lines of equal latitude are called parallels of latitude.



Publisher: ERI Publications Author: ERI and Don Cooper Title: Search and Rescue Fundamentals
 © This material has been copied under licence from CANCOPY. Resale or further copying of this material is strictly prohibited.

Figure 5.13 Parallels of latitude

Longitude

Longitude is measured as an angle. Figure 5.14 illustrates its definition. The reference plane in this case is one containing the earth's axis of rotation and passing through Greenwich, England. The curved line passing through the North and South poles and Greenwich is called the Greenwich Meridian and is 0° longitude.

Points in the Western Hemisphere have longitudes of between 0° and 180° W. Points in the Eastern Hemisphere have longitudes of between 0° and 180° E. For locations in BC, the longitude varies between 114° W for south-eastern BC to 138° W in the far north-west. In BC, a degree of longitude is about 70 km, decreasing in width as one moves further North. Lines of equal longitude are called meridians of longitude.

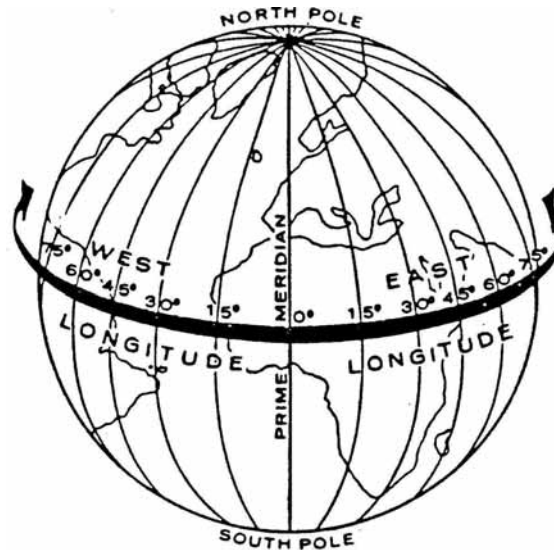

Publisher: ERI Publications Author: ERI and Don Cooper Title: Search and Rescue Fundamentals

© This material has been copied under licence from CANCOPY. Resale or further copying of this material is strictly prohibited.

Figure 5.14 Meridians of Longitude

The edges of topographic maps lie along meridians and parallels. Because a degree represents such a large distance for both longitude and latitude, degrees are divided into 60 minutes (60') and each minute is divided into 60 seconds (60"). Latitudes and longitude are indicated along the edges at 1' intervals using alternating black and white lines. Owing to the discrepancy between Grid North and True North, grid lines are not usually parallel to lines of latitude and longitude. A quick glance at a map will confirm this fact.

Determining latitude and longitude is different than UTM Grid coordinates in that you read up and then you **read left**. Latitude is given first and longitude second.

In order to find the latitude of a point its distance should first be measured from the top or bottom edge of the map, whichever is nearer. The same distance from the same edge should then be marked on the latitude scale on the left or right edge of the map. See figure 5.15. We know that the latitude increases as we progress north so in our example the point we are interested in lies between $50^{\circ} 53'$ and $50^{\circ} 54'$. Note that each of the black or white bars on the edge of the map represents 1 minute. To obtain the latitude to the nearest 5", fractions of a minute should be estimated in twelfths. As $1/12' = 5''$, $7/12'$ would correspond to $35''$.

A similar procedure is used for longitude. You will notice that the black and white bars are shorter. This is due to the lines of longitude converging at the north pole. Each bar still represents one (1) minute and still has 60 seconds in it. Using this procedure to find the latitude and longitude of a chimney is illustrated in Figure 5.15. For the chimney we would write $50^{\circ} 53' 35''$ N, $118^{\circ} 38' 40''$ W. Verbally we would say fifty degrees, fifty three minutes, thirty-five seconds North; one hundred eighteen degrees, thirty eight minutes, 40 seconds West.

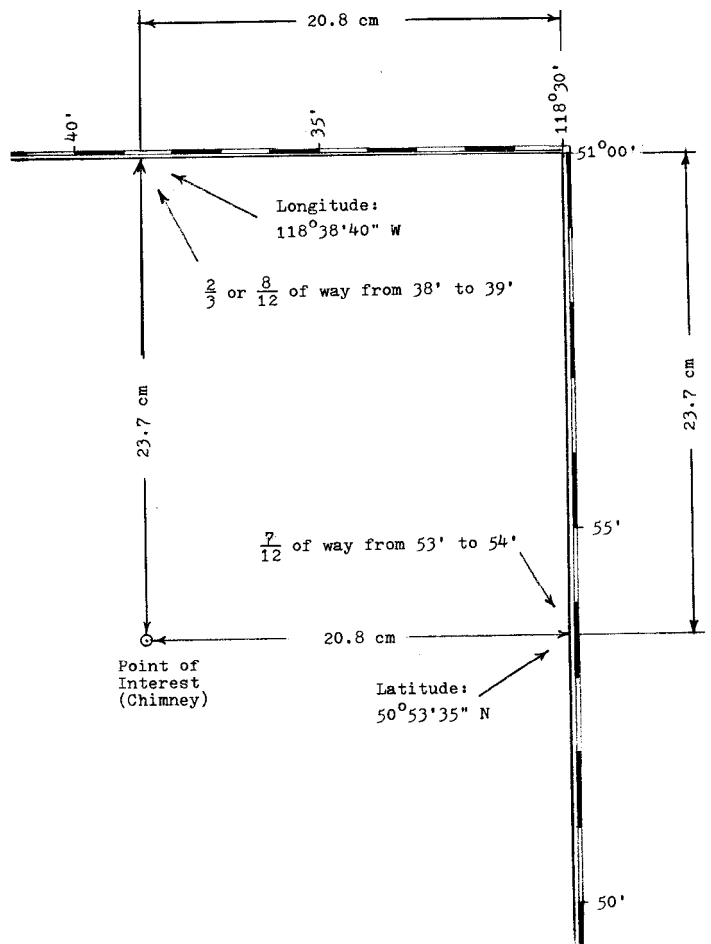

Figure 5.15 Determination of Latitude and Longitude

In giving lat – long co-ordinates, you always give the **latitude first, then the longitude.**

If the latitude and longitude are given and it is the point on the map that must be found, the latitude and longitude should first be marked on the scales on the map edges. The above procedure may then be reversed. Note that longitude increases from east to west, not west to east as with grid co-ordinates. More precise calculations of latitude and longitude may be made, but require much more careful measurement of the point's location and calculations that will take some time if a calculating aid is not available. The method just described should be sufficient for any situation encountered by a searcher in the field.

Lat/Long and GPS

Some GPS units give lat/long in degrees, minutes and decimals of a minute. For example, the chimney discussed earlier would be at 50° 53.58' N, 118° 38.67' W.

Map Symbols

Topographic maps identify numerous cultural and natural ground features, which can be divided into the following categories:

Culture: roads, buildings, urban development, boundaries, railways, power transmission lines;

Water: lakes, rivers, streams, swamps, rapids;

Relief: mountains, valleys, slopes, depressions;

Vegetation: wooded and cleared areas, vineyards and orchards;

Toponymy: place names, water feature names, highway names.

Most topographic maps have a list of symbols explained somewhere on the map. On some maps, road symbols are defined just left of the scale, and there is a huge list of symbols (Conventional Signs) in both English and French on the back of the map. On others, the symbols are on the border. Most symbols are self-explanatory, looking like what they represent. If in doubt, refer to the explanatory lists. Knowledge of these symbols can only come from frequent use of these maps. In studying maps of their own area, Search and Rescue personnel should familiarize themselves with the more limited number of signs on these particular sheets.

Contour Lines

The most distinctive feature of topographic maps is contour lines. These lines, marked in brown, join together points of the same elevation.

Recently published maps in the **1:50,000 series have a contour interval of either 20 m or 40 m**. Going from one contour line to the next means a change of elevation of 20 m or 40m respectively. Older maps in this series use a contour interval of 100 feet or about 30 m. In all cases, **every fifth contour line is made darker** as an aid in determining contour elevations.

The arrangement of contour lines can tell the skilled map reader much about the shape of the land. An immediate observation is that where contour lines are very close together, the ground is very steep, whereas where contours are well separated, the ground will be almost level.

The hill defined by the contour lines in the upper half of Figure 5.16 would have the slope given in the lower half of the figure.

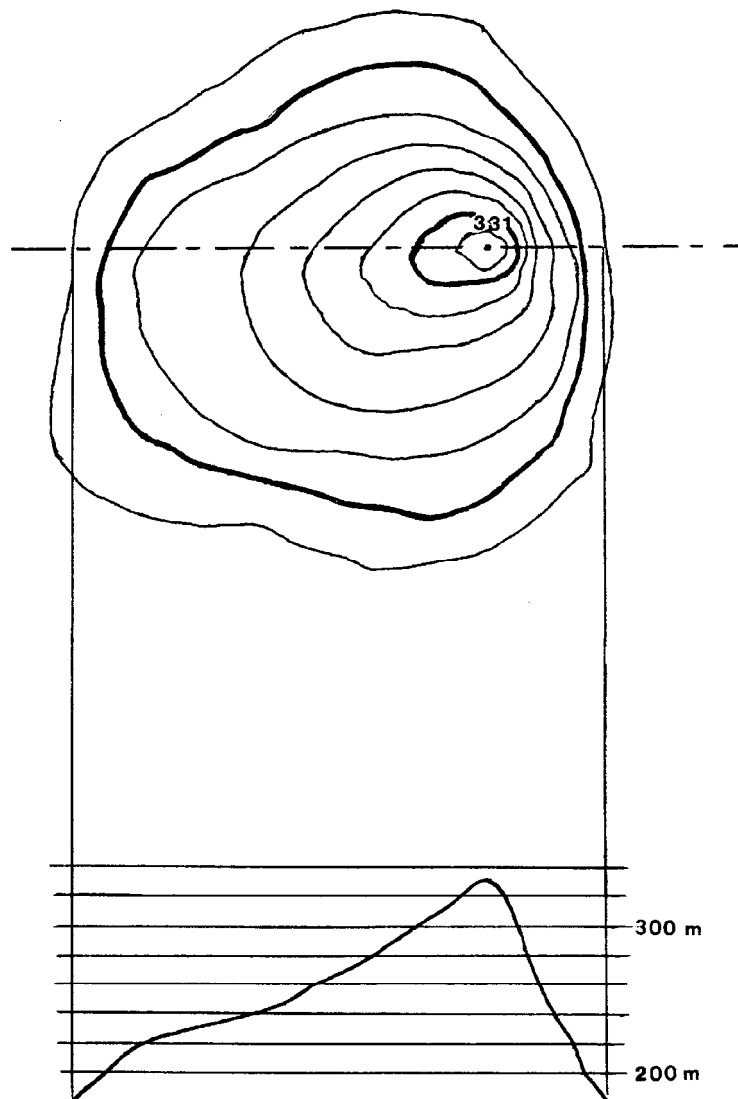

Figure 5.16 The Shape of a Hill Using Topographic Contours

Hill Gradient

Contour lines may be used to determine the average gradient of a hill. The change in elevation is first found by counting the number of contours on the hill on the map and multiplying by the contour interval.

In the diagram of the hill in figure 5.17, the contour interval is 20 m, the change in elevation between A and B is $7 \times 20 = 140$ m. The distance from A to B is 700 m according to the scale of the map, then the gradient of the hill is:

$$\frac{\text{Vertical rise}}{\text{Horizontal distance}} = \frac{140 \text{ m}}{700 \text{ m}} = 0.20 \text{ gradient}$$

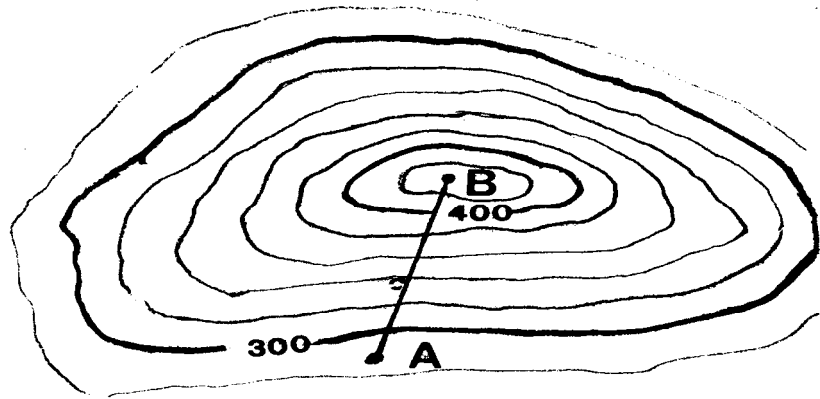

Figure 5.17 Gradient of a Hill

As 140 m is $1/5$ of 700 m, it is more common to express the gradient of this hill as 1:5 (one to five). The gradient of 1:5 means 1 m vertically for every 5 m horizontally.

Some caution must be exercised in interpreting such figures. While steady slopes with gradients of 1:2 or less can usually be climbed or descended easily, hazardous terrain may exist which the contours do not show. Steep cliffs with a height less than the contour interval (20 m) will not necessarily be indicated on the map.

On the other hand, slopes with gradients significantly greater than 1:2 can sometimes be easily negotiated if the surface is suitable. Nevertheless, knowledge of the gradient can be very helpful in assessing the difficulty of a particular route.

Generally speaking, if contours are smooth and regular it is unlikely they conceal any surprises, but if they are jagged and variable in spacing, the terrain is likely rough and short steep pitches may be lost between the lines.

Interpreting Contours

- The steeper the slope the closer the line spacing
- Valleys, ravines and gullies show up as V or U shaped lines pointing to higher elevation.
- Ridges appear as V shaped lines pointing to lower elevation.
- A saddle, pass or col will have higher ground on either side and have an hourglass shape.

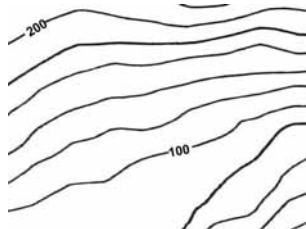

Gentle Slope

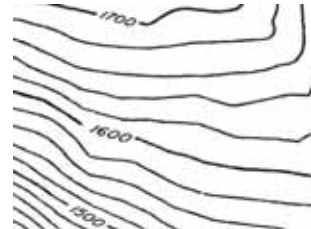

Moderate Slope

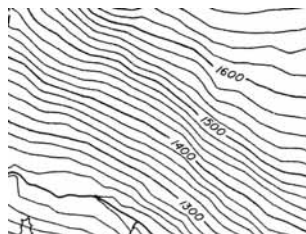

Steep Slope

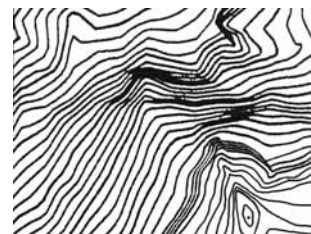

Cliffs

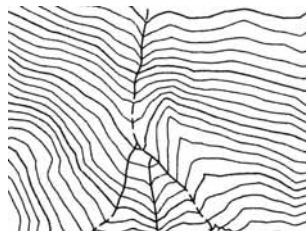

Gully w/intermittent stream

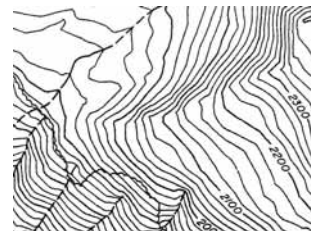

Ridge

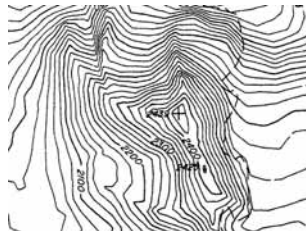

Peak or Summit

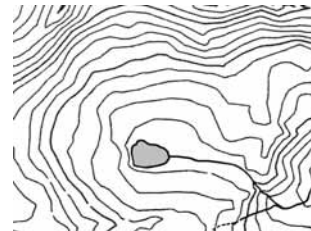

Bowl or Cirque, w/Lake

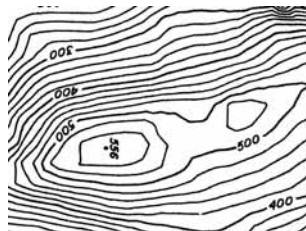

Saddle, Pass or Col



Tree Line, Clearing

Figure 5.18 Examples of Basic Topographic Features

Definitions**Col**

See saddle.

Crest

The highest part of a hill or mountain range - that line on a range of hills or mountains from which the ground slopes down in opposite directions.

Divide

The line along a range of hills or mountains from which the water flows in opposite directions, e.g. the Continental Divide

Drainage

An area in which all the water flows into one main creek or river.

Gorge

A narrow stream passage between steep rocky hills - a ravine with precipitous sides.

Gully

A water worn ravine.

Knoll

A small knob-like hill

Plateau

A table land - an elevated region of considerable area, generally fairly level.

Ravine

A long deep valley worn by a stream – deep narrow gorge or mountain cleft.

Ridge

The line along a hill or range of mountains from which the water flows in opposite directions, a divide – sometimes the crest of a line of hills along the horizon.

Saddle

A depression between adjacent hills or mountain tops, also called a Col.

Spur

A minor feature, generally in the form of a ridge running out from a hill or mountain.

Watershed

The line separating the water flowing into two different river systems -the edge of a river basin.

Route Profile

In a similar way, contour lines may be used to predict the shape of the land along the route a searcher may follow. The map in Figure 5.19 shows the route a searcher would have to follow to travel in a straight line from point A to point B. The searcher would have to drop from an elevation of 590 m to a stream at 500 m, then climb over a spur at an elevation of 610 m, then drop to another stream at 450 m before finally climbing to the hilltop of elevation 610 m. The sketch below the map in figure 5.19 shows a rough outline of this route and suggests a more circuitous route involving less change of elevation would be better. Such plots need not be done with great precision. Route selection will be discussed in more detail in the Map and Compass Chapter.

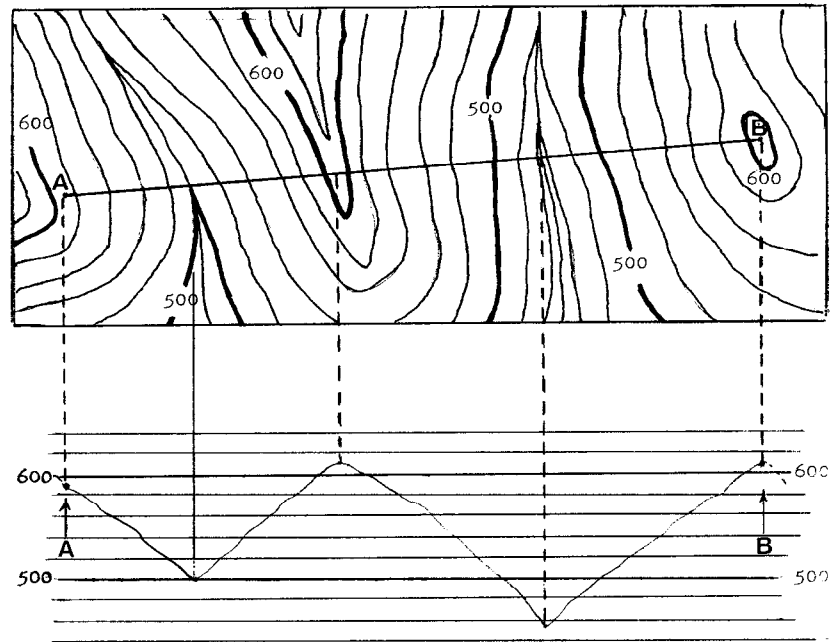
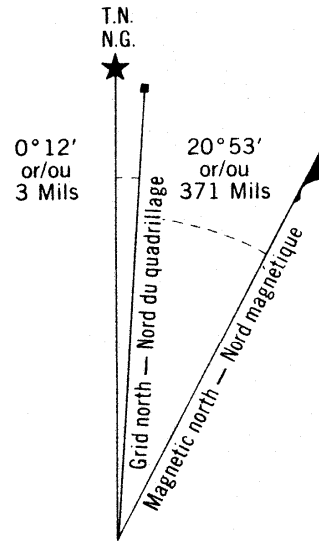

Figure 5.19 Sketching a Profile From a Contour Map

North

On the right side of a topographic map will be found a symbol similar to that shown in the figure 5.21.



Use diagram only to obtain numerical values
 APPROXIMATE MEAN DECLINATION 1991
 FOR CENTRE OF MAP
 Annual change decreasing 7.5'

Figure 5.21 Declination Information from a Topographic Map

T.N. stands for **True North**. True North is the direction of the North geographic pole, the point at which the earth's axis of rotation intersects the surface. Ideally, the vertical grid lines on a map will be in this direction. However, the problems of mapping a spherical surface on a flat map make some discrepancy necessary. The difference is small though, and the direction of grid north seldom differs from true north by more than 2°.

For SAR applications in BC, **Grid north will be assumed to be the same as true north.**

A magnetic compass, which will be discussed in detail in the next chapter, points in a northerly direction, but towards the North magnetic pole (**Magnetic North**) rather than the North geographic pole. In BC, magnetic compasses point in a direction between 20° and 30° to the East of True North.

An additional complication is that the angle between True or Grid North and Magnetic North is changing, typically decreasing by about 1/8° per year, precise information is given on the map. In general terms, if the map is placed so the magnetic North line is pointing in the same direction as the compass needle, the map will be correctly oriented. Using a map and compass together will be discussed in the Map and Compass Chapter.

Care of Maps

The following points should be noted in looking after maps.

- a) A map is a fairly fragile thing. Unless it is treated with care, particularly in the field, it will soon come to pieces. Maps are often precious and the supply of them is never unlimited. **Handle them with care.** Wet, wind, grime, folds and tears are the greatest enemies of maps.
- b) A quick way to destroy a map is to open it full out in the open air. There is always a slight breeze to catch it and start small tears that quickly spread. Tears start just as easily when a map is opened and refolded in a restricted space, particularly where there is some wind. The first thing to prevent tears is to be able to fold it so that any part can be referred to without refolding.
- c) Figure 5.21 shows how to fold a map. First, fold it in half down its longest length with the map showing outwards. Then, fold across the other way, accordion fashion, as illustrated. The number of folds will depend on the size of the map. The aim is to reduce it to a convenient size for carrying and, at the same time, ensure that there is a reasonably large area for studying when two folds are opened like a book. Folded thus, any part of the map can be studied by opening the appropriate folds. Do not fold a map in what might be called the obvious way - with map inwards, to do so ensures that no part of the map can be looked at without opening it full out.
- d) A map is easily damaged when it is folded. If opened and refolded several times, it will begin to lose detail and may even tear at the folds. For protection it should be kept in a map case or some other type of protective cover. A map case made of clear plastic allows use of the map while still in the case.
- e) Try to keep the map from getting wet; when it is wet it tears and picks up dirt easily. If it gets wet, open it out as soon as possible and allow it to dry.
- f) Some of the government topo maps are now available on Tyvek (a plastic like paper) which is much more durable than paper. Plasticizing of maps is also an effective method of increasing their durability. The use of alcohol soluble markers (not water-soluble for obvious reasons) for writing on plasticized maps is strongly recommended as markings can be easily erased after the search.

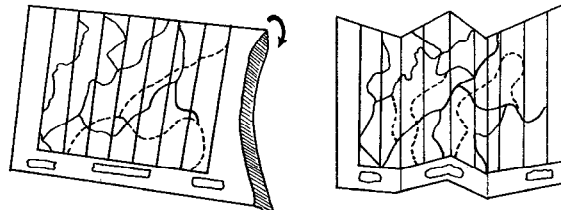

Figure 5.21 Correct Way to Fold a Map

Remember to fold the map so the area of interest can be seen.

Additional Resources

Graydon, Don, and Hanson, Kurt. *6th Edition, Mountaineering, The Freedom of the Hills*. Seattle, WA: The Mountaineers, 1997.

Kjellstrom, Bjorn. *Be Expert with Map & Compass*. New York, NY: MacMillan General Reference, 1994.

Seidman, David. *The Essential Wilderness Navigator*. Camden, MD: International Marine/Ragged Mountain Press, 1995.

Further references listed in the Bibliography.

Chapter Review

Please answer the following questions on a separate sheet of paper so that another student can use this manual. Use figure 5.23 to answer the following questions. The answers to these questions are located at the end of the manual.

1. What is the UTM grid coordinates and the latitude and longitude of the following points? Describe the latitude and longitude to the nearest 5 seconds.
 - a. The sawmill
 - b. Hagwilger Peak
 - c. The end of the road on Mudflat Creek
 - d. The outlet of the large lake on Mudflat Creek.
2. You are requested to report to 905 232. What do you find there?
3. You are going to be transported to 55° 11' 5"N, 127° 35' 30"W. What will you find there?

Answer **True** or **False** for the following statements:

4. A ridge on a map will have the contour lines pointing to higher elevation.
5. The closer the contour lines the steeper the hill.
6. 1:20 000 is more detailed than 1:50 000
7. Two points in Canada can have the same UTM grid references.
8. UTM grid lines are 2 km apart on a 1:50 000.

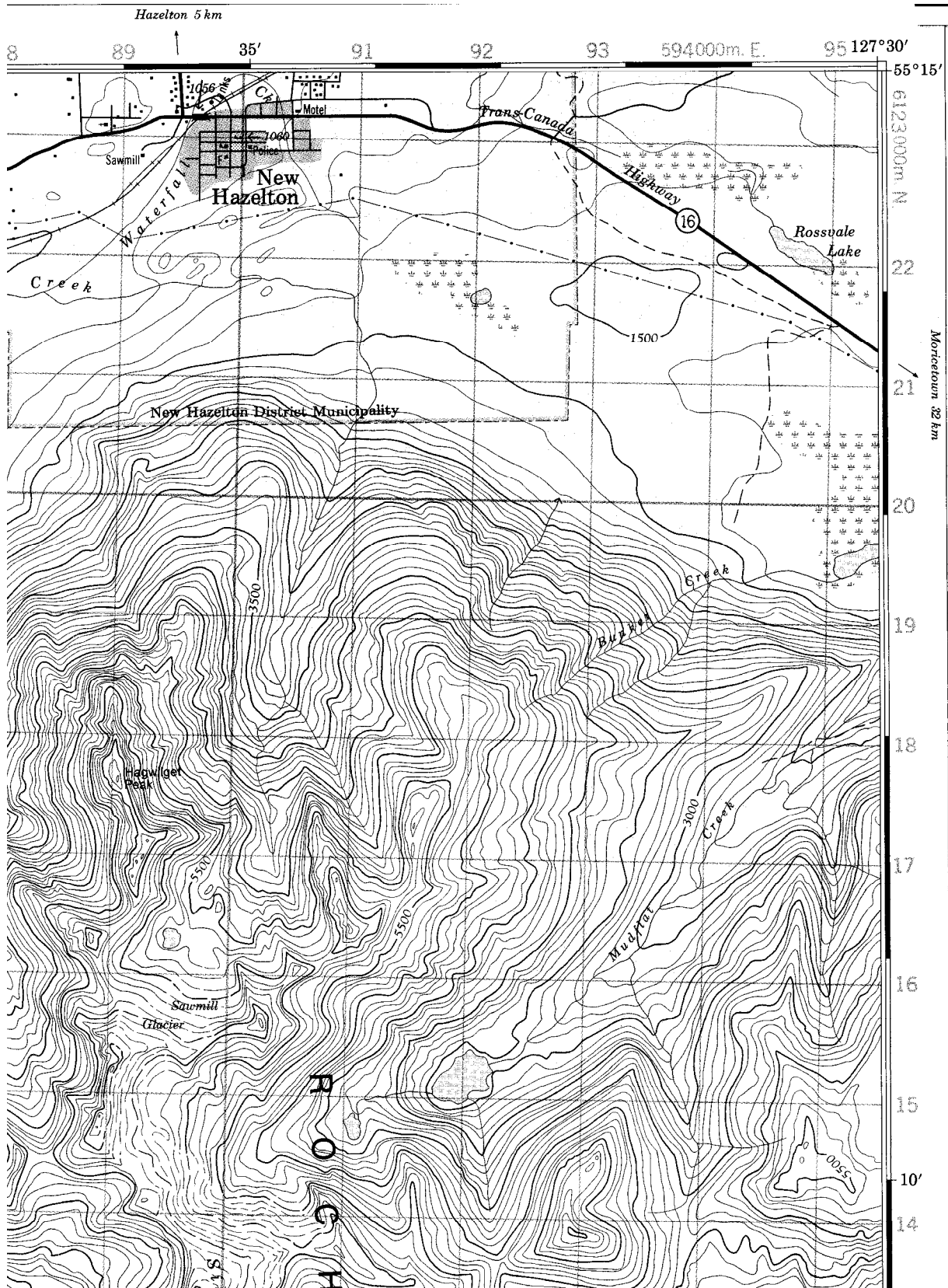

Figure 5.22 Map Exercise



Figure 5.23 Index Map for the 1:250 000 Scale Maps

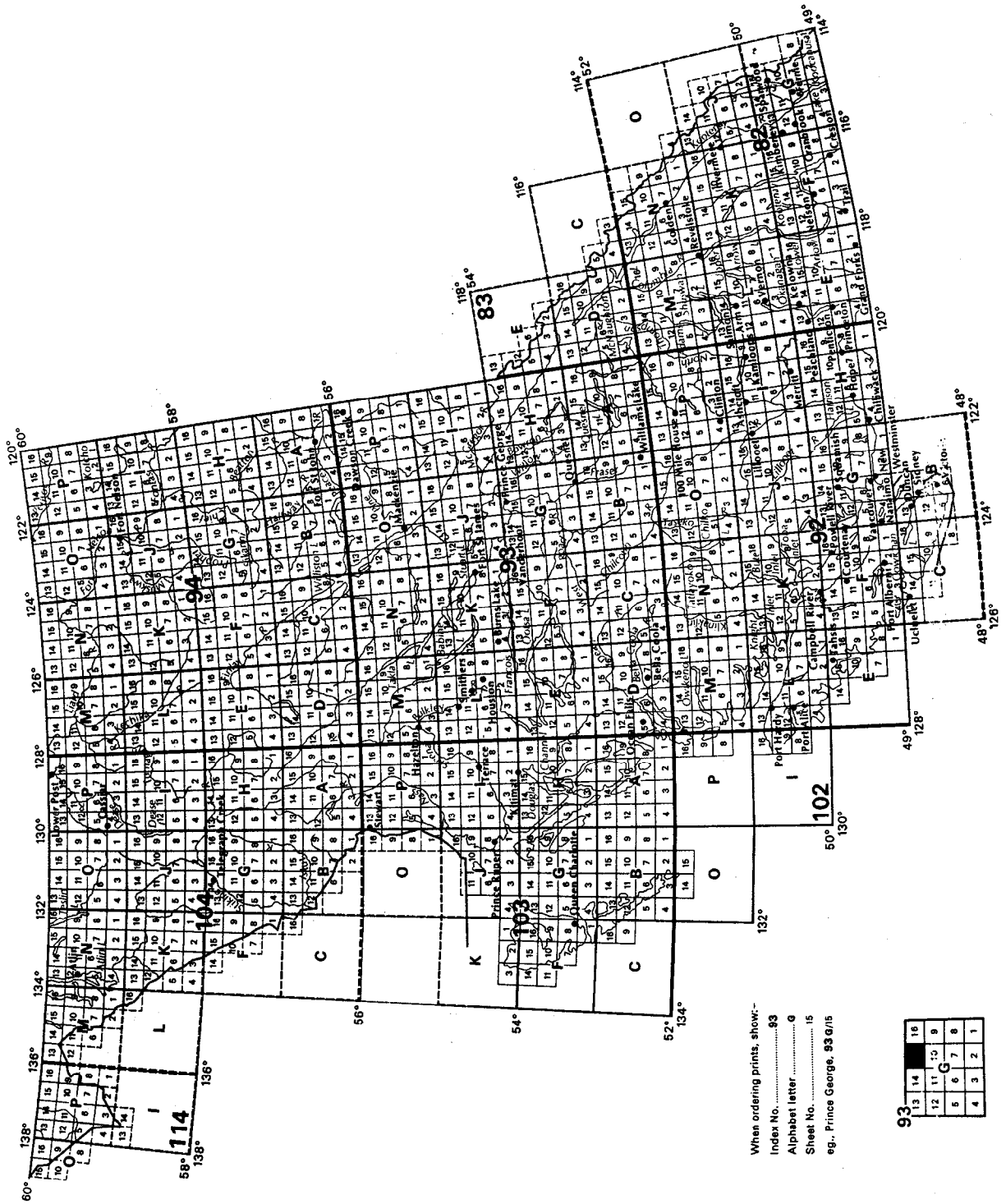

Figure 5.24 Index Map for 1:50 000 Scale Maps

Chapter 6 - The Compass

Upon completion of this chapter, you will be able to:

- Explain the use of the 360 degree system in defining direction.
- Identify the parts of a compass, i.e.:
 - base plate
 - magnetic needle
 - orientation arrow
 - sight and sighting line
 - graduated dial
 - meridian lines
- Distinguish between magnetic north, true north and grid north.
- Adjust a declination adjustable compass for magnetic declination.
- Use a compass to take a bearing and to locate a given direction.
- Use a compass to take a back bearing.
- Explain factors affecting a compass, i.e.:
 - electrical currents
 - magnetic fields
 - ferrous metals
- Navigate around obstacles.
- Use aiming off to navigate to a point on a baseline.
- Make approximate measurements of distance through pacing and other techniques and know the limitations of these methods.

The Degree System

To better understand the information presented, have a compass and topographic map available to examine and use as each function and technique is described.

Before discussing the use of a compass, it is necessary to make clear the degree system of defining direction. A circle can be divided into 360 degrees. If one thinks of a person standing at the centre of a circle, the possible directions that a person can face can be defined in terms of 360 degrees. By convention, the direction of **True North** is 0° or 000 (also 360°), East is 90° or 090 (pronounced ZERO-NINE-ZERO), South is 180° or 180 (ONE-EIGHT-ZERO) and West is 270° or 270. A direction of Northeast, being halfway between North and East would be 045.

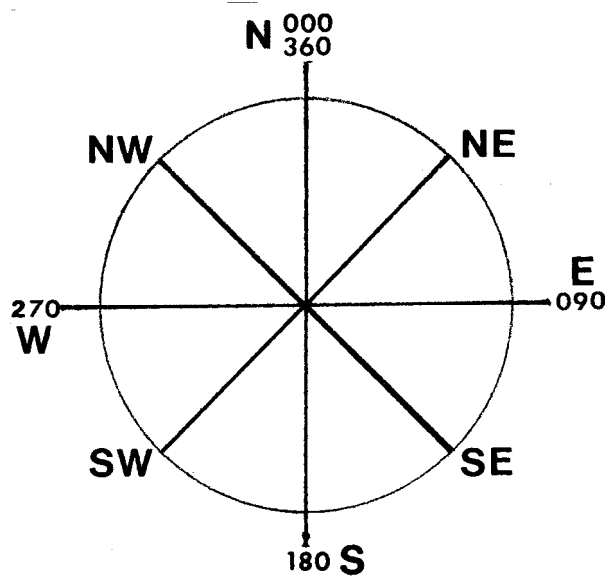

Figure 6.1

Directions defined in this way are called **bearings**. In theory each degree can be subdivided into minutes and seconds as well, but no situation in basic search and rescue will require such precision. In the discussion that follows, all bearings will be rounded off to the nearest degree.

Be aware that the Canadian Military use mils instead of degrees. Instead of dividing a circle into 360 degrees it is divided into 6,400 mils.

The Compass

PEP recommends the use of a declination adjustable compass for use in SAR work. Once the declination has been adjusted on the compass no calculations are required (declination is described on page 6-5). Several manufacturers make this type of compass. These compasses also have a hinged lid with a mirror as well as a transparent base plate.

Take your compass in hand and find each feature shown in Figure 6.2. The compass needle has a red and white end. The red end points in the direction of **Magnetic North** since the magnetic needle aligns itself with the magnetic field of the Earth and the magnetic field of the Earth focuses at the magnetic north pole. The compass housing is black (aluminum in older models) and can be rotated.

The compass needle is used to take bearings in the field and, as we will see in the map and compass chapter the meridian lines are used to take bearings from a map.

The use of the different parts of this compass will be explained in the sections that follow.

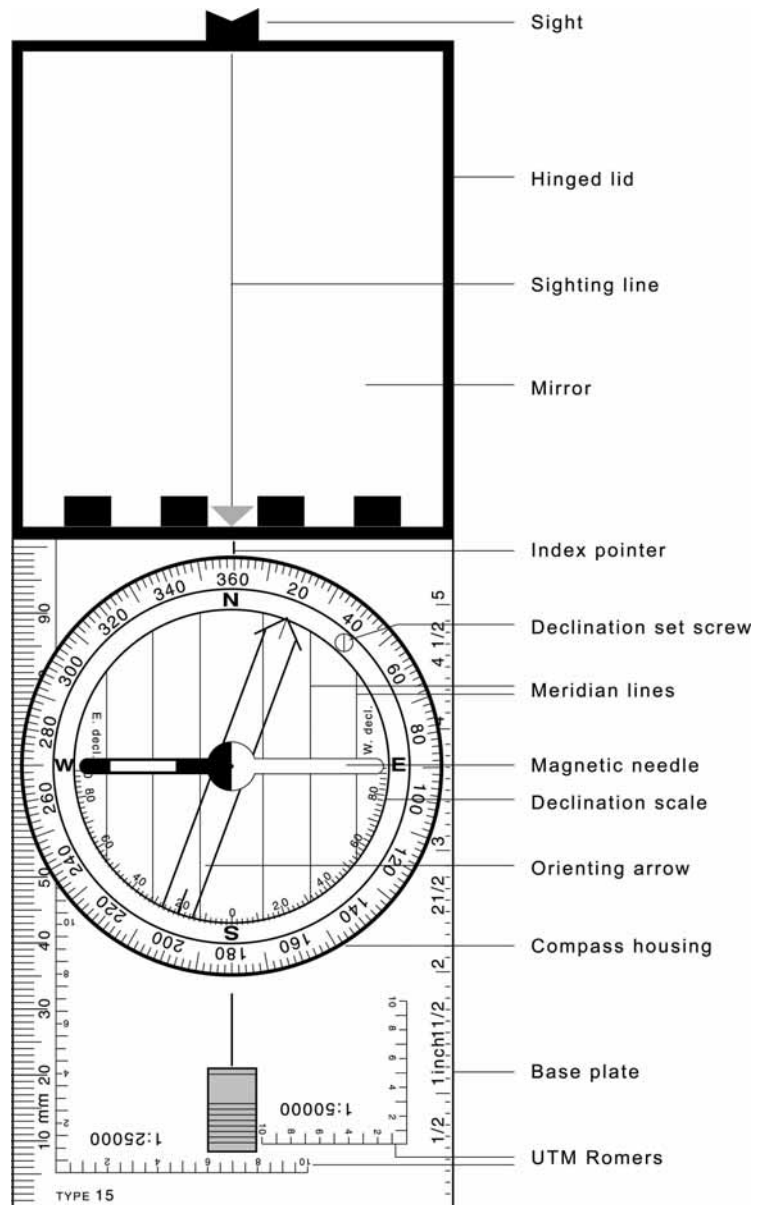

Figure 6.2 Features of the typical Search and Rescue Compass

Use of a Compass to Fix Direction

Magnetic Declination

In the chapter “Maps”, we talked about true north, magnetic north and grid north. To review, **True north** is the earth’s geographic north pole. It is the point where the lines of longitude meet. The needle on a magnetic compass points to, and therefore establishes, the direction of **Magnetic North**. **Grid north** is the north direction in which the grid lines on your map point towards. True north, magnetic north and grid north are not in the same position.

In order to fix other directions, the bearing of Magnetic North must be known. This bearing can be found on most maps and is the angle between True North and Magnetic North, known as the **magnetic declination**.

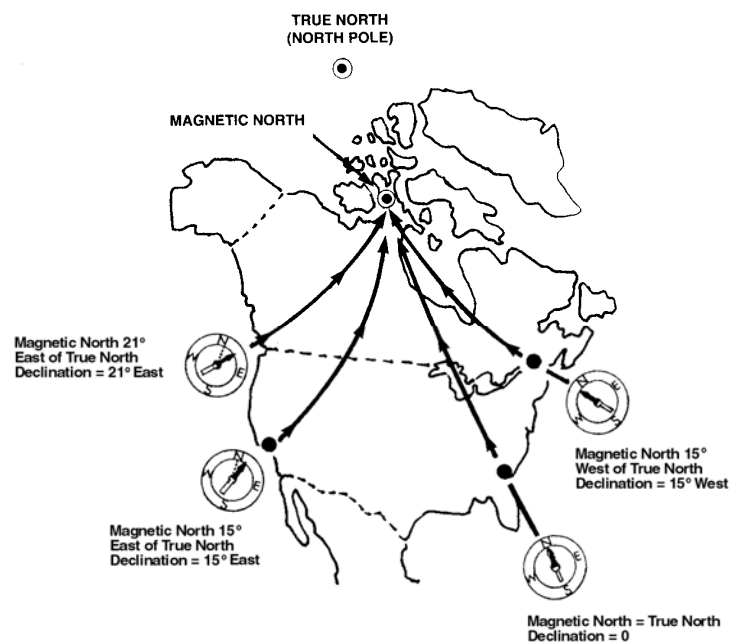
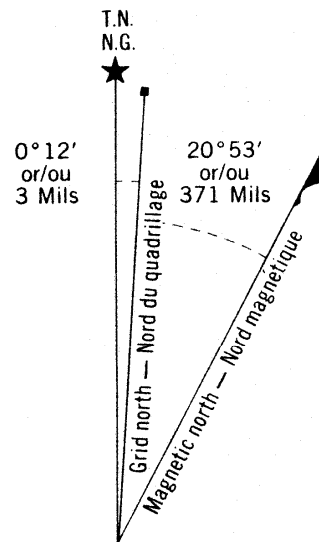

Figure 6.3a Magnetic Declination

Although this angle gives the theoretically correct value, the angle between Magnetic North and Grid North turns out to be much more important when using a compass in conjunction with a gridded map.

The data necessary to determine either angle is given in the information on the right margin of 1:50 000 maps. The grid bearing of Magnetic North is given directly, but the true bearing requires a subtraction or addition to be made. As all work done by ground searchers is likely to be in conjunction with a gridded map, **Grid North and the associated bearings will be used almost exclusively.**

However, the difference between True and Grid North must be remembered if talking to a pilot who understands North as True North.



Use diagram only to obtain numerical values
 APPROXIMATE MEAN DECLINATION 1991
 FOR CENTRE OF MAP
 Annual change decreasing 7.5'

Figure 6.3b Map Declination Information

The amount of declination changes from year to year so a correction for annual variation of the declination must be made. A particular map might have the declination diagram shown above. The magnetic declination of Magnetic North relative to Grid North was $20^{\circ} 53'$ in 1991. As this angle is decreasing by $7.5'$ annually, it has decreased by $52.5'$ ($7.5' \times 7$) by 1998. Converting $52.5'$ to minutes and seconds gives $52' 30''$. Thus, the 1998 declination would be $20^{\circ} 00' 30''$ or a bearing for Magnetic North of 020 (accuracy down to $30''$ is extremely difficult with a compass). Various web sites are available that correct for magnetic declination.

Knowing that 020 is the direction in which the compass needle points, all other directions are fixed as shown in Figure 6.4.

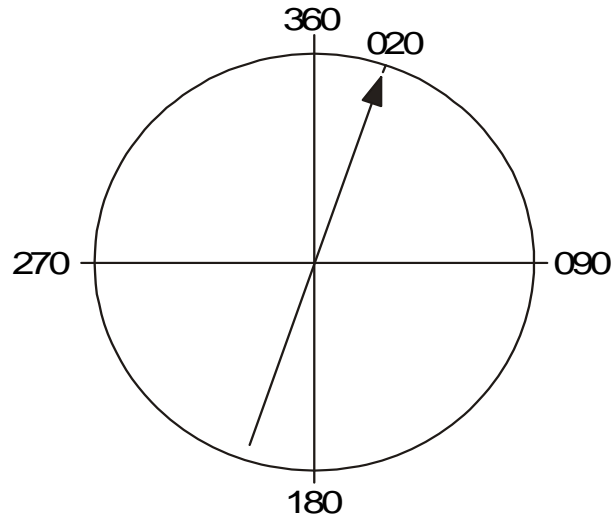

Figure 6.4 Magnetic Declination Fixes all Other Points

Although information is given to allow declination calculations to the nearest minute, rounding off to the nearest degree gives more than sufficient accuracy for most applications in SAR.

Websites are also available which will calculate the magnetic declination for a given point. One of them is maintained by National Resources Canada and is located at:

http://www.geolab.nrcan.gc.ca/geomag/e_cgf.html

Setting the Declination

A declination adjustable compass is designed to greatly simplify the problem of the difference between True/Grid North and Magnetic North. Once you set the declination for your area on the compass you do not have to pay any attention to it unless you move to a new map area.

In the inner circle of the compass, a scale that runs from 90° W decl. to 90° E decl. can be seen. If the setscrew in the compass housing at the NE position is turned with the attached screwdriver, the orienting arrow will move against this scale.

To correctly set the declination, the screw should be turned until the tiny mark in the **base** of the orienting arrow points to the known declination. In making this adjustment, it must be noted that the divisions on both the declination scale and the compass housing are 2°, not 1°, so a setting of 23° would be halfway between two divisions. When correctly set for a declination of 20° E, the orienting arrow and declination scale should appear as in Figure 6.5. The compass housing will be correctly oriented for Grid North.

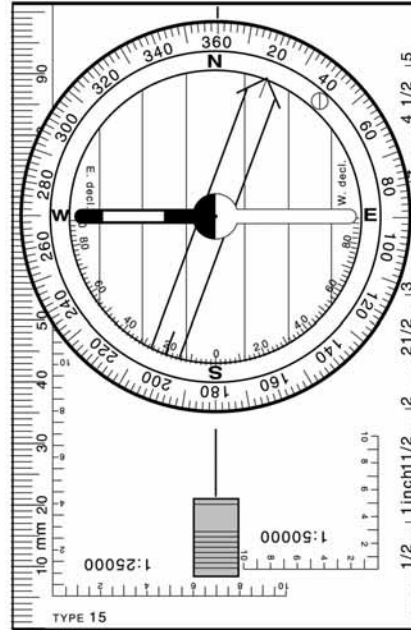

Figure 6.5 Declination Set for 20° on Newer Compasses

On some compasses (especially older models) the arrow end of the orienting arrow is adjusted until it points to the declination scale. The setup would appear as in Figure 6.6.

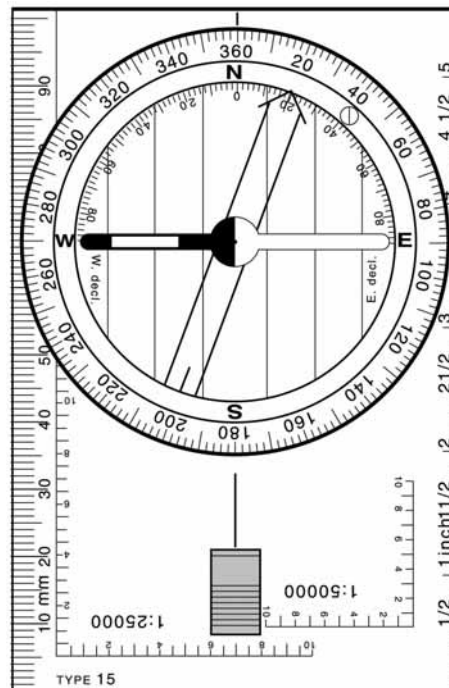

Figure 6.6 Declination Set for 20° on Older Compass

Bearing Relative to Grid North

Taking a Bearing

Once the declination is set any bearings that are taken are relative to Grid North.

On a search you may want to determine what the bearing is to a familiar landmark such as a mountain peak, from where you are located. To take a bearing:

1. The compass has to be aimed towards the object that you want to take the bearing on. This can be done two ways.
 - a) The quicker but less precise way is to hold the compass opened out flat and level at waist height with the mirror end away from you, and point the sighting line at the peak.
 - b) Increased accuracy can be obtained by using the sighting method.
 - i) Hold the compass at eye level and adjust the cover to approximately 45° so that the mirror reflects a top view of the compass dial. See Figure 6.7.

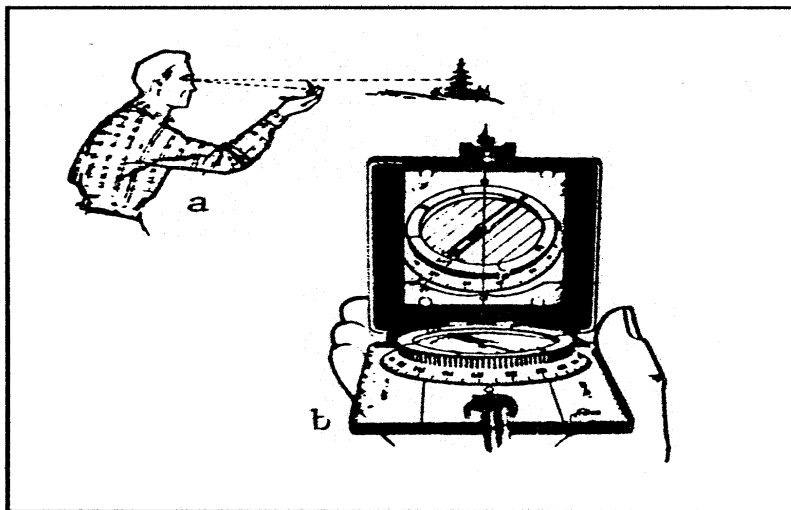

Figure 6.7 Sighting Method of Taking a Bearing

- ii) While looking in the mirror, move your sighting eye sideways until you see the sighting line intersect the two luminous points as in Figure 6.8.

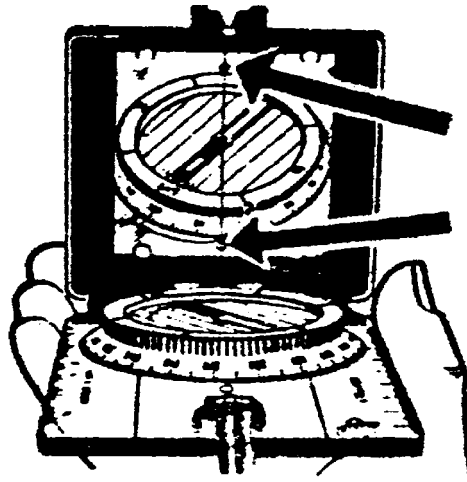

Figure 6.8 Sighting Line Oriented Correctly

2. While keeping the compass aimed toward the object turn the compass housing until the red end of the needle lies within and parallel to, the red end of the orienting arrow. Make sure the compass is level as the compass needle can “bind” and not move to the correct position if the compass is tilted.
3. The reading at the index pointer is the bearing of the object. Now that you know how to do it, step outside and take bearings on objects in all directions. Take the bearing both with the compass at waist height and with the sighting method. Remember that with the declination set these bearings are taken relative to Grid North.

How might you use this in SAR? If you were in the bush, and needed to know where you were, you could take bearings on recognized landmarks and triangulate your position. Triangulation will be covered in the chapter “Map and Compass”.

Taking a Back Bearing

A back bearing is the bearing from a landmark to where you stand. It is 180° opposite of the bearing from where you stand to the landmark. It is used in several procedures such as triangulation, returning back the way you came and in looking for magnetic anomalies. There are two ways to take a back bearing.

One way is to take a bearing on the object but instead of reading the bearing at the index pointer read the back bearing at the luminous line that is 180° opposite to the index pointer.

The other way to take a back bearing is to sight the compass at the landmark but line the white end of the compass needle over the red end of the orienting arrow (this is opposite of what you would do to take a bearing). Then read the back bearing at the index pointer.

Following a Bearing

Suppose your Ground Search Team Leader assigns you to be the compass bearer for a grid search, and says that you must follow a bearing of 135° (SE) for 300 m. To use your compass to follow a bearing of 135° you would:

1. Set the given bearing at your index pointer. In this case the compass housing is rotated until the index pointer between the mirror and the housing points to 135° .
2. Hold the compass level and turn your whole body around until the red end of the magnetic needle falls within the red end of the orienting arrow. The sighting line on the mirror now points in the 135° direction. Figure 6.9 shows how the compass would appear when aligned in the direction of 135° .

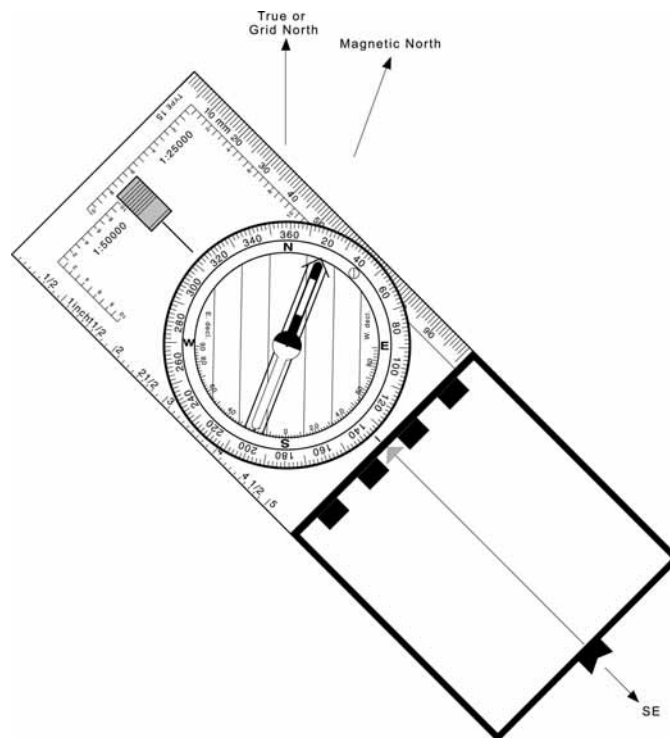

Figure 6.9 Appearance of Compass when Aligned for a Direction of Travel of 135° (SE)

3. Holding the needle exactly this way, find an identifiable object on the bearing that you can walk toward. This is often a tree, but it may be a rock, a bush, a peak, even a bend in the river or the end of a lake. The important thing is that you must not lose sight of it as you walk. If that could be a problem, choose something closer.

4. Once you have picked out an object at that bearing, walk to it. You don't need to look at your compass again until you have reached it. It is not necessary to climb over difficult obstacles: as long as you reach the object, you will be following the course.
5. When you reach it, sight again, and find a new object on that bearing to walk to. Keep repeating this process to continue along the bearing.

Lateral Drift

If you lose sight of your intermediate landmark and want to make sure you are still headed towards it, turn around and take a back bearing to your starting position. You will have to move one way or the other to line up the back bearing to your original starting position. Then turn around and take another bearing in your original direction. If you do not check your alignment when an intermediate landmark is lost, lateral drift can occur putting you off on a parallel course.

Considerable practice is essential if accurate bearings are to be consistently achieved. Setting and taking bearings using a compass without declination adjustment is described in map and compass books.

How Far off Course

For each degree of error you will be about 17.5 m off for each kilometre you travel. Therefore, if you are off 5 degrees on a 5 km hike, you will be $5^\circ \times 5 \text{ km} \times 17.5\text{m} = 437.5\text{m}$. If you are thinking in miles and feet, then figure that you will be off about 92 feet each mile for every degree of error.

Problems in Following Bearings

Dense Bush In open country following a bearing will be easy. In dense bush, you may have to take repeated bearings at trees, or even individual branches, only a few meters ahead. And if you take your eyes off the bearing point for a moment, you may lose it. Remember, if you lose your intermediate landmark you are subject to lateral drift (see above).

Local Magnetic Attraction Your compass needle is magnetic, and may waver toward any large iron or steel object, or respond to local magnetic fields. If you are near a car, snowmobile, or outboard motor – especially if they are running – the needle may be way off. Inside a building, the wiring creates magnetic fields which attract the needle. If a rifle, knife, radio, battery powered watch, batteries, belt buckles or pacemaker is too close, it will affect the compass. Being near railroad tracks or power lines can also deflect the compass needle.

Navigating Around Obstacles

On land there are many places where magnetic anomalies occur due to magnetic ore deposits. The best test for influence by magnetic rocks or localized fields is the “**back bearing**” technique. When the compass bearer reaches the object that was sighted on the desired bearing, he may turn around and sight at the starting point. If the sighting has been done correctly and local magnetic attraction is not present, **the white end of the compass needle should be aligned over the orienting arrow**. If not, a more careful analysis will be necessary.

Fog and Snow In dense fog or heavy snow there may be no natural objects to take a bearing on. Mountaineers on snowfields have a method of following a bearing without reference points. On glaciers one person sights along a bearing, the other walks along the bearing until he is just at the limit of visibility. That person then acts as a target and the compass bearer can tell him to move right or left until he is exactly in line. The accuracy of the bearing can be improved by having the target person take a back bearing on the compass bearer and adjust for any error. The compass bearer moves to the target person then the target person moves out on the bearing again.

Often as you travel on a bearing you will reach an obstacle such as a lake, river or canyon that you need to go around. There are two ways to go around the obstacle.

If you can see across the obstacle, take a bearing on an obvious landmark on the other side. Before going around the obstacle make sure you can identify where your starting point is or mark the point with flagging tape (preferably biodegradable) or by breaking a branch. Walk around the obstacle to the landmark. Take a back bearing on your starting point to confirm that you are still on course.

If you cannot see across the obstacle then you will have to use another technique. Turn 90° from your bearing and follow this new bearing counting your steps until the obstacle is passed. Return to the original bearing and walk past the obstacle. Now turn 90° in the opposite direction from your original bearing and walk the same number of steps so that you return to your original course. Once the correct number of steps have been counted turn back onto the original bearing. This is outlined in Figure 6.10.

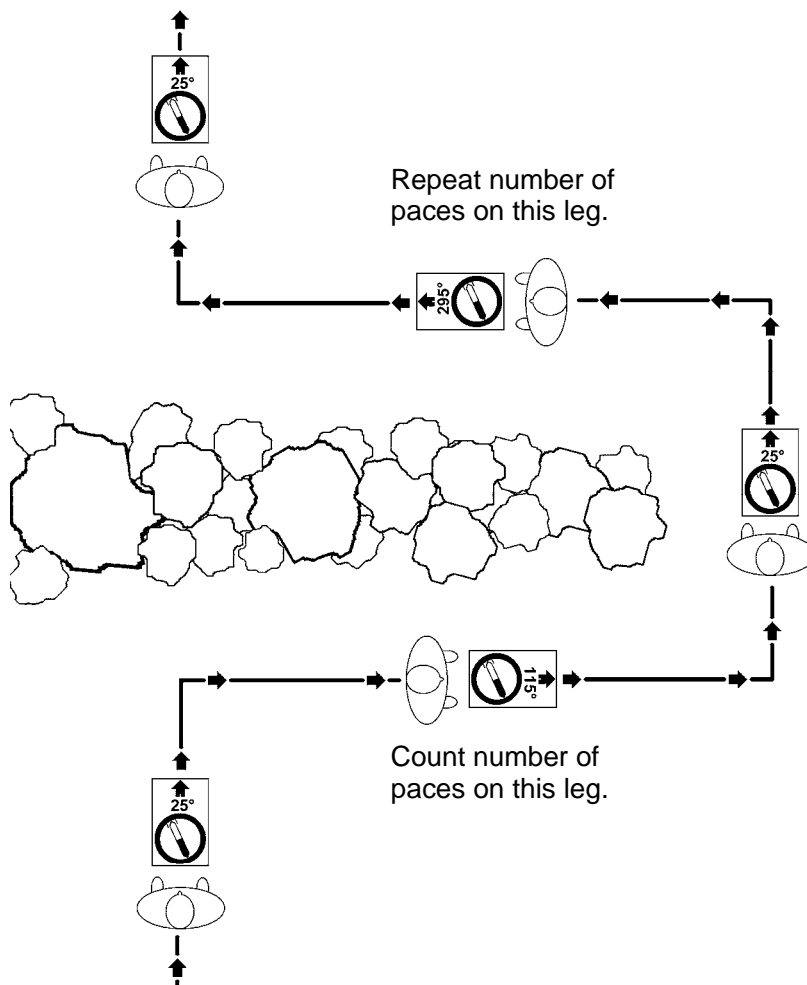

Figure 6.10 Navigating Around an Obstacle

**Aiming Off
(Deliberate Error
Reckoning)**

On occasion, a searcher may have to follow a bearing away from a baseline (also called a handrail) such as a road, trail, or shore, then return to the point of origin following a back bearing.

Following the back bearing is easy; don't change the original bearing, just put the **white** end of the magnetic needle in the orienting arrow instead of the red. The difficulty comes in finding the exact point of origin.

For example, if you left a car on a road and followed a compass bearing to a peak, then tried to return exactly to the car, you might well be off a few degrees. Arriving at the road, the car might be out of sight, and you would not know which way to look for it, because you would not know which way you were in error. If, for example, you were about 5° off at the end of 5 km (not hard to do), you would be about 437m from your target, and if you couldn't see it, you might walk in the wrong direction to locate it.

To prevent this, take a bearing 5° off one way or the other from the direct back bearing. In other words, make an intentional error. Then, when you hit your baseline, you will know which way to turn even with the inevitable error in compass work. This is called aiming off or deliberate error reckoning.

Aiming off can also be used when travelling along a route. Identifying “handrails” which are well defined features that can be easily recognized and followed such as creeks, cut lines, and cliff bands. Aim off to the handrail and follow it to your desired destination.

It must be noted that aiming off only works if the point to be located is on a handrail (baseline). It does not work for locating a small point surrounded by non-descript terrain.

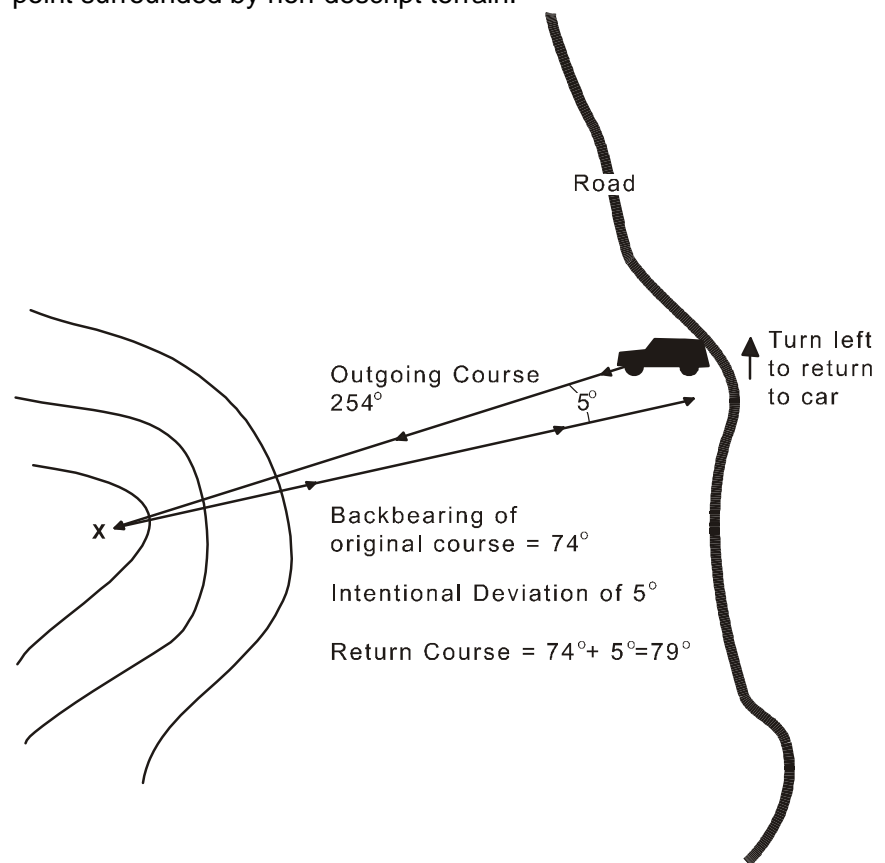

Figure 6.11 Aiming off to Return to a Baseline

Distance Measurement

Dead Reckoning: During early stages of a search, accurate measurement of distance is rarely needed. “dead reckoning”, or knowing your speed and elapsed time, is usually adequate to tell you how far you have traveled.

For example, if you estimate that you are moving one km every 20 minutes and you then walk for 40 minutes, you may reasonably expect to have gone about 2 km. This method is imprecise, but frees your mind for the search. When only a few searchers are in the field, as there is at the start of most searches, you may need every bit of attention for the search, rather than careful distance calculation.

Clearly, time will vary with the nature of the terrain and the vegetative cover. While you might travel 1 km in only 8 minutes on open ground, it might take 3 or 4 times as long in heavy bush or steep country. Elapsed time estimates improve with experience.

Frequent Position Fixing: By determining your exact position on the map whenever an opportunity presents itself, you can keep yourself oriented with respect to distance. A combination of Dead Reckoning and Position Fixing is often used, and makes it easier to spot landmarks. (Position Fixing with compass is described later). Increasing use of Global Positioning Systems (GPS) makes this much quicker and easier than position fixing with a compass.

Pacing

When accurate distance measurement is necessary, as in flagging grid search boundaries or plotting uncharted trails and maps on a Search Status Map, and no GPS is available, pacing is the most practical method.

How to Pace: Measuring distance accurately by pacing it requires considerable experience. Not only does every person have a different sized pace, but the size of a person's pace (or step) will depend on his speed and type of ground he is traversing. To obtain information about one's pace it is desirable to travel previously measured distances and count one's pace to travel these distances. The effect of varying speeds, of rough ground, and of slope should all be investigated. The figure that should be obtained in each case is the number of paces or steps that are required to travel 100 m.

The use of the pace (2 steps) or the single step as the counting unit is optional. A person might find that on smooth, level ground, 122 steps (or 61 paces) are required to travel 100 m. Thus to walk 400 m at this rate would require counting 122 steps (or 61 paces) 4 times.

It is not necessary for all members of a search team to be proficient in pacing, and indeed, many of us do not have the mental math skills to calculate on the move. Some searchers carry tiny hand calculators to make the process easier.

In order to measure distance with reasonable accuracy by pacing, you must first find the number of paces, (or steps, whichever you prefer) is required to travel 100 m. over the type of county you will be measuring.

First, measure a course of 100 m over ground typical of what you will be walking. You can also measure a course of 50 m and multiply by two. Don't choose the smoothest or least vegetated ground – take something that fairly represents the real terrain.

Walk the course counting your paces or steps. It is critical that you take normal steps! Don't try to stretch them to an even meter. If you have walked out 100 m, walk and count it back again, and average the two if there is a difference.

You now have the number of steps it takes you, and you alone, to walk 100 m. If, now, your SAR Manager tells you to follow a compass course for 400 m, you simply multiply your 100 m step count by 4.

Odd distances are only slightly more complicated, but will probably require a pencil and paper. If you need to measure, for example, 170 m, then you simply multiply your 100 m step count by 1.7. If you need to measure 520 m, by 5.2, etc.

Using the Hip Chain

An excellent tool that is coming into increasing use in SAR is the hip chain. It is a device used by resource agencies and prospectors to measure distance and lay out lines on the ground. It is a plastic belt case containing a spool of thin string and a measuring device that registers as the string is paid out. The user simply ties the string at this starting point, and can then read his counter at any time to determine how far he has gone. This method is more exact than pacing if a reasonably straight line can be maintained.

In the US, some teams have developed a technique of encircling a high-probability search area with hip chain string. A helper follows the hip chain carrier and attaches paper arrows to the string that indicates the way out. If the search subject then runs into one of these, he is guided out.

The hip chain is also excellent for laying out lines for a closed-grid search, in place of flags. Biodegradable string is available and should always be used, as it is quite difficult to pick up all the string once laid.

Hip chains are not commonly carried by search teams at this point because their cost – around \$100 – but are extremely useful. Obtaining hip chains would be a good target for SAR societies' fund raising events.

Additional Resources

Graydon, Don, and Hanson, Kurt. *6th Edition, Mountaineering, The Freedom of the Hills*. Seattle, WA: The Mountaineers, 1997.

Kjellstrom, Bjorn. *Be Expert with Map & Compass*. New York, NY: MacMillan General Reference, 1994.

Seidman, David. *The Essential Wilderness Navigator*. Camden, MD: International Marine/Ragged Mountain Press, 1995.

Declination calculation:

http://www.geolab.nrcan.gc.ca/geomag/e_cqf.html

Further references listed in the Bibliography.

Chapter Review

Please answer the following questions on a separate sheet of paper so that another student can use this manual. The answers to these questions are located at the end of the manual.

1. What is the difference between grid north, true north and magnetic north? Which ones are used in SAR?
2. Why are declination adjustable compasses used in SAR?
3. Is the declination adjustment scale on your compass at the point of the arrow or at the base of the arrow?
4. What are the two ways to aim the compass when taking a bearing? Which is more accurate?
5. What can cause local magnetic attraction?

Answer **True** or **False** to the following statements.

6. Back bearings are 90° from the bearing.
7. True north and its associated bearings will be used exclusively in SAR.
8. It is important to keep the compass level while taking a bearing.
9. Back bearings can be used to prevent lateral drift.
10. Declination is a constant, over time, in any given area.

Chapter 7 - Map and Compass

Upon completion of this chapter, you will be able to:

- Orient a map to terrain using a compass.
- Use a compass to determine the bearing to be followed between two points on a map.
- Given the bearing, use a compass to plot the direction on a map.
- Use triangulation to fix one's position on a map.
- Use a single bearing and another reference to fix one's position on a map.
- Use a map to select a suitable route for travelling between two points.
- Follow a simple course of less than 2 km in the field that has been plotted on a map.
- Use an altimeter in conjunction with map and compass for fixing position.
- Review GPS navigation systems.
- Identify the benefits and drawbacks in using GPS for navigation.
- Demonstrate travelling skills used for his/her environment such as:
 - Trails
 - Bush
 - Talus/scree
 - Snow
- Define technical versus non-technical terrain and identify the limitations of Ground Search Team members.

Orienting a Map with a Compass

While navigating on a search it is recommended that the map be oriented to the terrain so you can identify visible landmarks, find your position and plan your route. Orienting a map is turning the map so that the north on the map is located north in the landscape. There is two ways to do this:

1. One way is look at your surroundings and identify known features such as mountains, roads, rivers and valleys. Then turn the map until the known feature on the map is lined up with actual surroundings. You have now oriented the map by inspection.
2. A simpler way is to orient the map with a compass. First make sure that your compass is adjusted for magnetic declination then set the compass at 360° . Place it on the map with the meridian lines on the compass lined up with the North-South grid lines on the map. Now turn the map and compass together until the red end of magnetic needle is in the red end of the orienting arrow. The map is now oriented with the terrain by using a compass.

Finding a Bearing on a Map

In the next procedure – finding a bearing on a map – the magnetic needle will not be used.

If the searcher wishes to know what bearing he must follow on the ground to get from point A to point B on a map, the following procedure is followed:

The long edge of the compass (either one) is placed along the line joining A and B with the sighting line (mirror end) towards B. Exactly where on this line the compass is placed does not matter.

Holding the compass in this position the compass housing is turned until the meridian lines on the base of the inside of the housing are aligned with the North-South grid lines on the map with the orienting arrow towards the North.

The position of the magnetic needle does not matter – it has nothing to do with this procedure. The reading on the compass housing at the index pointer will be the bearing to follow in going from A to B. Figure 7.1 illustrates the arrangement of the compass when set to read a bearing from a map. In this case, to go from A to B would require following a bearing of 135° .

One edge of the compass base has a centimetre scale impressed on it and provided that the points are not too far apart, this scale can be used to determine distance from A to B using the procedures discussed in the chapter on maps.

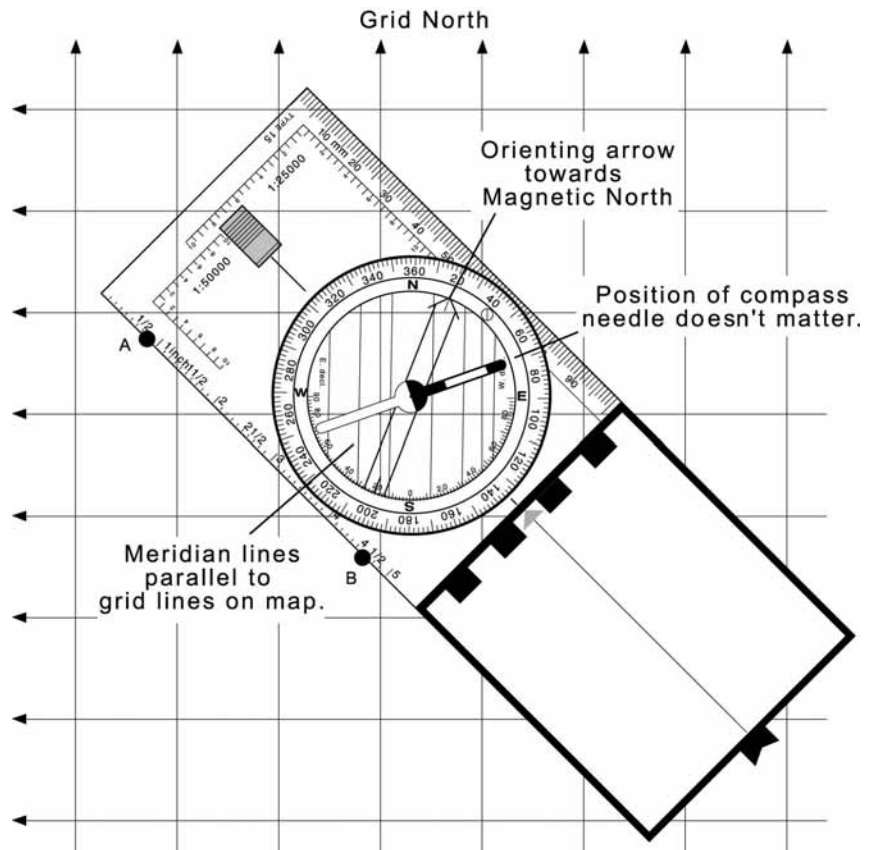

Figure 7.1: Arrangement of a compass to determine the bearing required for travelling from Point A to Point B

The things you must remember are:

- The sight line (mirror end) must be towards the destination.
- The meridian lines must be aligned with the grid lines.
- North on the compass housing must be oriented to Grid North on the map. If it is pointing to the bottom of the map your bearing will be off by 180°.
- The position of the magnetic needle does not matter.
- Before going to use this bearing in the field the declination has to be set for the map being used.

Plotting a Bearing on a Map

If the position of a point on the map is known and the bearing from that point to an uncharted point is also known, the searcher may mark this direction on the map using a procedure similar to the one just described.

The compass housing is first adjusted to the desired bearing. It is then placed on the map with one long edge just touching the known point near the end of the compass opposite to the mirror. Keeping this known point on the edge of the compass, the **base** is rotated around the point until the meridian lines are parallel to the North-South grid lines with north on the compass housing pointing to Grid North. Again, the magnetic compass needle position does not matter.

A line drawn along the edge of the compass in the direction of the direction-of-travel arrow will give the desired direction. If the distance to the unknown point is also known, the unknown point may now be plotted on the map. This procedure is illustrated in Figure 7.2. In this case, the bearing from point A to a second point is known to be 230° . The compass is adjusted to 230° , then placed on the map and rotated around point A until the meridian lines are parallel to the grid lines.

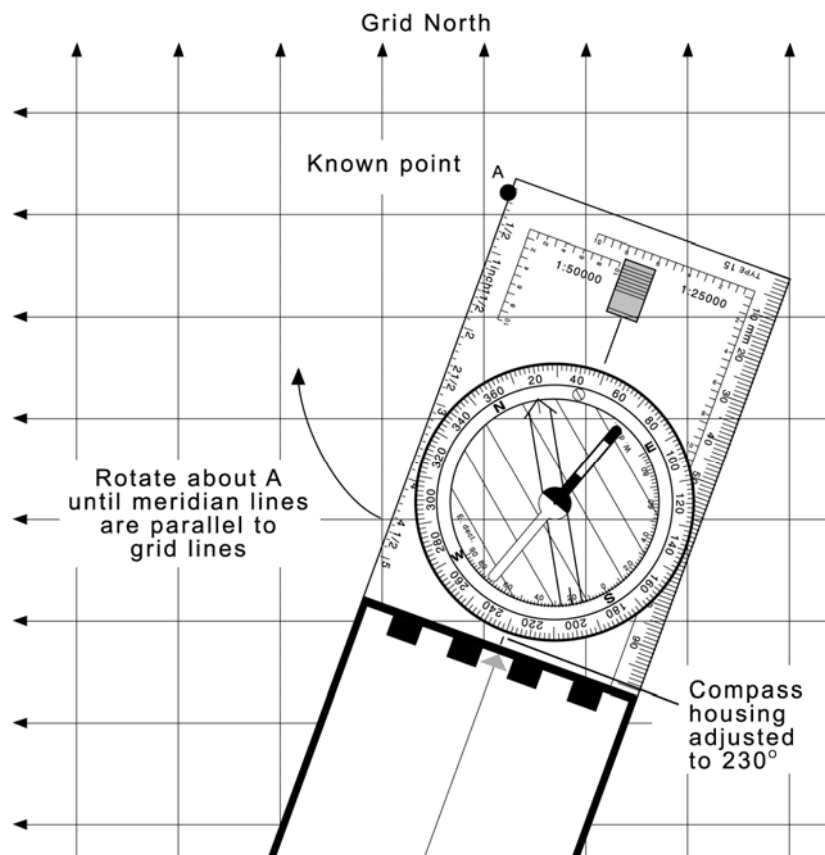

Figure 7.2a: Using a Compass to Plot a Bearing of 230° from a Fixed Point (original compass position). Position of compass needle does not matter.

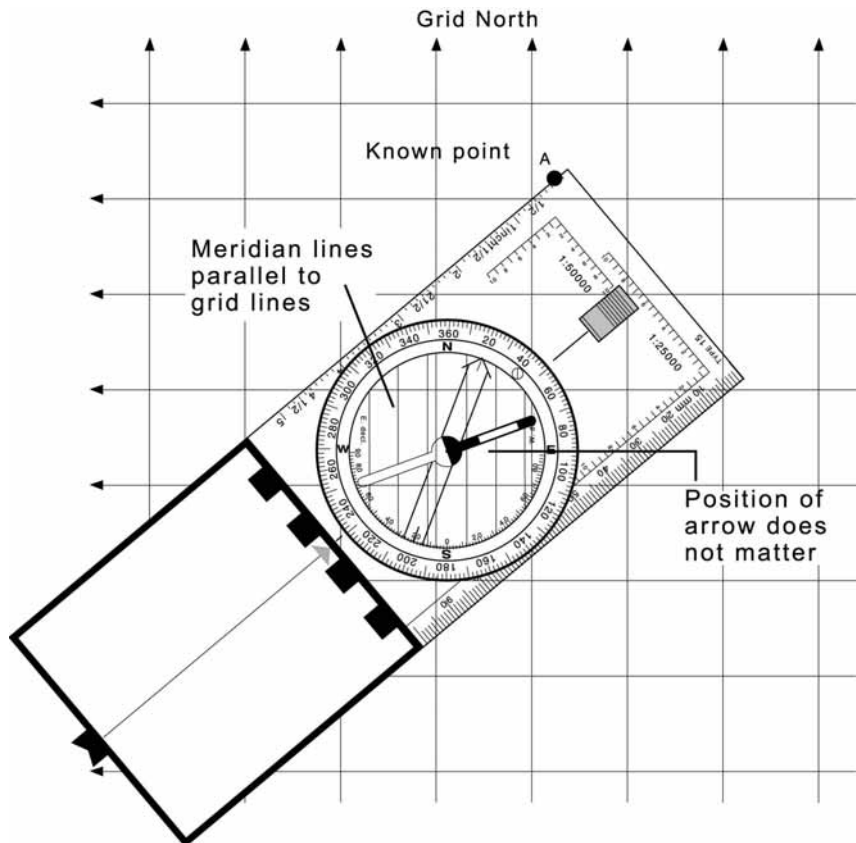

Figure 7.2b Finished compass position for plotting a bearing of 230°. Meridian lines are parallel to gridlines. Position of compass needle does not matter.

Triangulation: How to Find Your Position

While out on a search you may want to know where you are on the map. A technique called triangulation (also called resection) is used to determine this position. To use this technique you have to be able to spot two distant landmarks that can be positively identified on your map. As this is not always possible to do (e.g. in cloudy weather, or treed flat terrain with no identifiable landmarks) the technique has some limitations.

The most frequently used landmarks are mountain peaks, but such man-made features as bridges, tall chimneys or prominent buildings are commonly used. Also used are small islands, the end of peninsulas, sharp ends of lakes, or any precise point that is identifiable, clearly seen and which appears on the map. To triangulate:

Triangulation

- Sight on the landmark and determine its back bearing by aligning the white end of the compass needle over the orienting arrow instead of the normal red end. This will be the bearing from the landmark to your position as if you were standing on the landmark.
- Plot (draw) the bearing from the sighted landmark onto the map, just as if you were standing on the landmark and plotting a line of travel on that bearing.
- Do the same for the second landmark, plotting this line also.

Since you must be located on both lines, the point where they cross will be your location. For maximum accuracy, the two known points should be well separated, and preferably at something like right angles to each other. The closer they are, the less accurate the technique will be. Conversely, if they are at almost 180 degrees, they will be less accurate.

Figure 7.3 illustrates this technique. From the searcher's position, the back bearing to the hilltop at point A, grid co-ordinates 236 566, is found to be 146° . The back bearing to a bridge at point B, grid co-ordinates 278 564, is found to be 192° . These bearings from points A and B are plotted on the map. Their intersection at point C with grid co-ordinates 269 517 indicates the searcher's location.

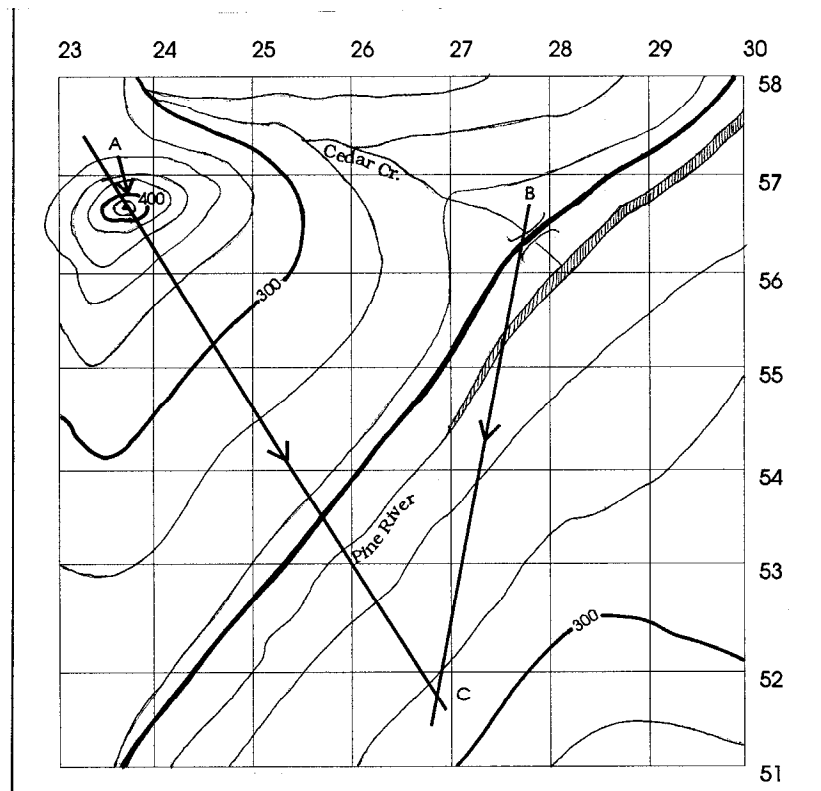

Figure 7.3 Triangulation to Fix a Searcher's Position (See text for detail)

Line of Position

Only one back bearing needs to be taken if an additional fact is known. If, for example, the searcher is walking along a road, the intersection of the back bearing with the road will define the searcher's position. This is called a line of position since you must be somewhere on the back bearing from the landmark and you are defining your position using the additional fact (e.g. on the road).

This technique would apply equally to any other linear feature marked on the map such as a stream, power line, railway line, or lake shore along which the searcher is known to be located.

A special case of this situation arises when the searcher knows his or her elevation as a result of using an altimeter. Altimeter use will be discussed at the end of this chapter. As long as the searcher's approximate location is known, his or her position can then be established along a particular contour line. Figures 7.4 and 7.5 illustrate these forms of position fixing.

In Figure 7.4, the searcher is somewhere along the creek marked on the map. The back bearing to the mountaintop is found to be 123° . By plotting this bearing from the mountaintop on the map, the searcher's location is fixed at S.

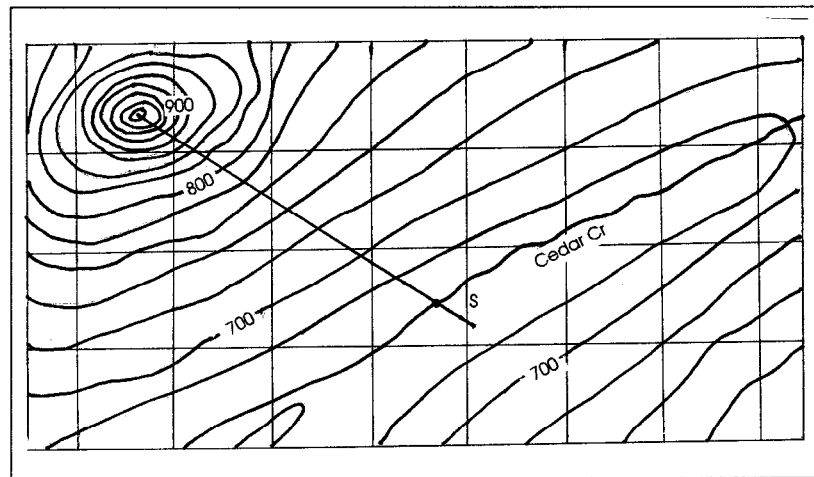

Figure 7.4 Fixing Location using a Known Travel Aid (Creek) and Back Bearing to a Known Point (Mountaintop)

In Figure 7.5, the searcher's altimeter indicates an altitude of 960 m. The back bearing to the tall chimney near the railway line is found to be 278° . By plotting this bearing from the chimney on the map and finding its intersection with the 960 m contour, the searcher's location is fixed at S.

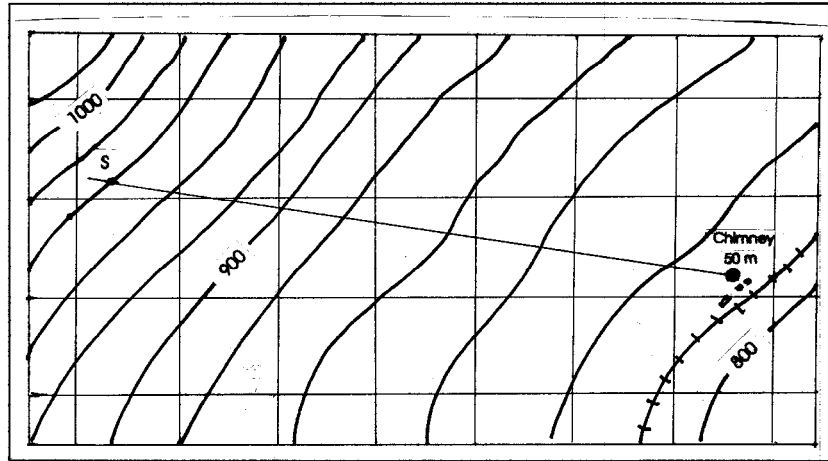

Figure 7.5 Fixing Location using a Known Elevation and Back Bearing to a Prominent Object (Chimney)

In theory, these techniques require finding the point of intersection of only two lines. Greater confidence in position location can be achieved by using a third line if at all possible. If the three lines intersect, or come very close to intersecting at one point, this position is almost certainly the correct one. It is quite unusual for your compass work to be so precise that all three lines intersect perfectly. Significant differences between the points of intersection will require that you repeat your plotting with more care.

Triangulation to Locate a Signal

Triangulation can also be used to fix the location of a signal (e.g. smoke, reflector, or sound). From your known position on the map take a bearing on the signal. Plot this bearing on the map and move to another known location and take another bearing on the signal or have a second team take a bearing on the signal from another known location. Plot this second bearing on the map and where the bearing lines cross gives a rough location of the signal. This will only work if the signal can be seen or heard from the two locations.

Route Finding (Orienteering)

A situation may arise in a search where a search team is asked to get to a particular point as fast as possible. Discovery of a new clue may have necessitated a change of tactics, or the victim may have been found injured and assistance may be required with transportation. Assuming the search team knows their present location, their fastest route to the point requested will not necessarily be a straight line. If the terrain is uncomplicated and the distance relatively short; straight line navigation is probably best, but this situation will not always be the case.

The topographic map should alert the searcher to any obvious barriers or hazards on the straight line route. If these are significant, an indirect approach involving other navigational techniques must be employed.

Certainly, choosing a route on which the slope is acceptable, and on which excessive alternating descending and ascending does not occur, is a very important consideration. As such a route may be quite circuitous, distance measurement is likely to be quite difficult. As a result, the searcher should first aim to get to a point that is fairly close to the required point and which can be reached and identified relatively easily. Once at this intermediate point, straight line navigation may be used to get to the desired destination. The more changes of direction, the greater the chance of error.

Figure 7.6 illustrates such a procedure. A search team at point A, grid co-ordinates 171 808, receives word that an aircraft has spotted what could be the wreckage of a missing plane in fairly dense forest at point B, grid co-ordinates 202 766. The SAR Manager wishes them to get to point B as quickly as possible. The straight line path, marked -----, is impractical for two reasons. A very steep hill immediately in front of the search team could prove quite dangerous, and the river running down the middle of the map is impossible to cross without a bridge. A good route might be the line marked ACDB. The team would descend from the hill to the road somewhere near C, using the gradually sloping spur on the hill's eastern flank. It would then follow the road to where it crosses the river on a bridge at D. At this point, it could be established that the desired point would be found on a bearing of 096° at a distance to be determined from the map scale. Straight line navigation could then be used.

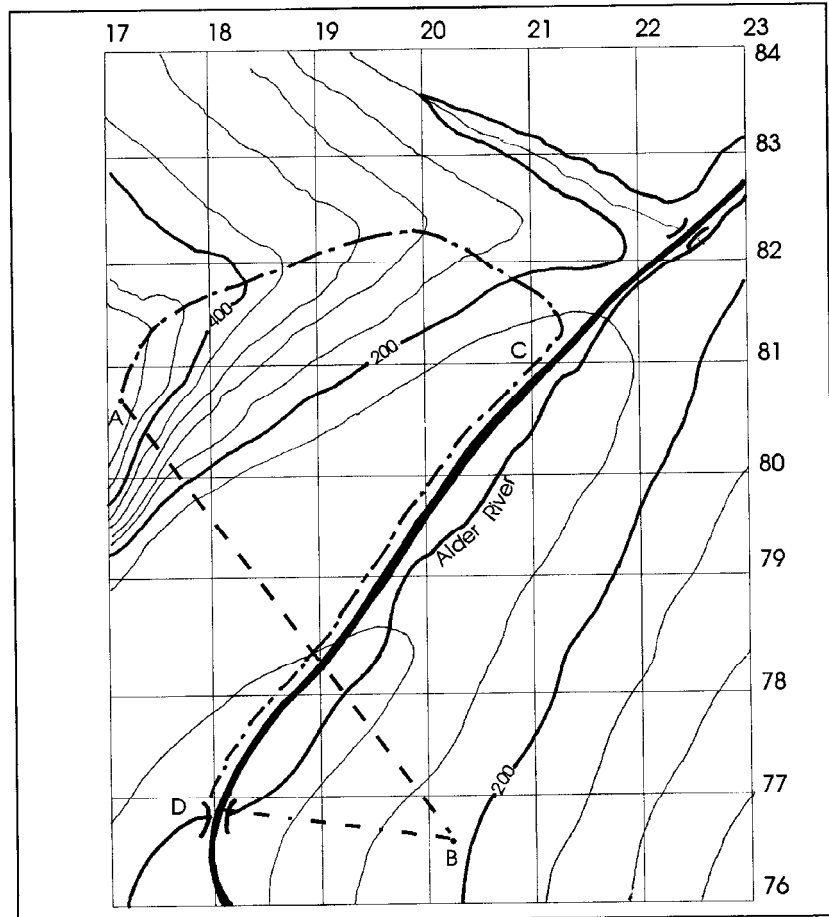

Figure 7.6 Choosing the Fastest Route from A to B. (See text for details)

The increasingly popular sport of “Orienteering” uses these same skills although usually on a smaller scale. Orienteering races involve finding a series of markers which have been placed at specified locations on a relatively large scale (typically 1:10 000) map, and getting to each of the markers as quickly as possible. The navigational skills required in orienteering are very similar to those in SAR. SAR group team members are encouraged to participate in orienteering activities going on in their area. There are few better ways to polish map and compass skills.

Altimeters

As mentioned earlier in this chapter, the effective use of map and compass in some areas can be enhanced through the use of an altimeter. An altimeter is a modified barometer that measures altitude. Atmospheric pressure decreases with higher altitude and an altimeter measures the atmospheric pressure but displays the reading in units of altitude. By using an altimeter to determine your altitude and thus which map contour you are on, you may take a bearing on a known point and plot a single line of position on your map. Your position is where the line crosses the contour.

In times of poor visibility, an altimeter can be used to determine when a searcher has reached a particular point on a road, trail, or other travel aid. The position will be found where the contour line for that elevation crosses the trail on the map.

As atmospheric pressure varies with weather conditions as well as altitude, an altimeter must be set frequently for it to operate properly. It should be set at a known elevation before beginning a search, and then be checked and reset if necessary at any known elevations along the search route. If the altimeter reading increases significantly when the searcher knows no significant increase in elevation has occurred, falling atmospheric pressure is indicated which is usually a sign of deteriorating weather conditions.

Altimeters are available from most suppliers of outdoor recreational equipment. The cost can vary from \$50 or less for the least expensive models to several hundred dollars for the most reliable ones. Moderately priced wristwatches are now available with built-in altimeter/barometer modes, which will read in either feet or meters. It is a great help for mountain search teams to have several altimeters in the party.

Global Positioning System (GPS)

GPS receivers allow for quick and accurate identification of one's position based on information the unit receives from GPS satellites. These satellites transmit their position and timing information to the receivers. The receivers use this information to triangulate the receiver's location in latitude and longitude. Some GPS receivers can readily toggle between lat/long and UTM grid co-ordinates. The receiver needs to obtain a signal from three satellites to pinpoint a position. Obtaining a signal from a fourth satellite provides more accuracy as well as the elevation of the position. The GPS receivers have a potential accuracy of locating a position within 15 meters however the U.S. Department of Defence introduce selective availability which lowers the accuracy to within 100 m. This is often accurate enough for most SAR requirements.

One of the benefits of using GPS receivers in SAR tasks is to pinpoint positions when traditional navigational techniques (such as triangulation with a magnetic compass) cannot be performed. Examples of situations in which this would be useful are: finding a injured subject at night and transmitting the location to base, describing the position of a potential clue in a whiteout and noting its position for future reference, or informing the SAR Manager exactly where the search teams are located in terrain in which traditional triangulation will not work (eg. pine forest with no identifiable landmarks).

In addition to pinpointing your position, GPS receivers can also be used to guide you to your destination. An example of how this could be of benefit to a SAR Group would be in guiding evacuation teams to the location of a found subject. Once the subjects' position is known the co-ordinates could be given to the evacuation team and entered into the GPS receiver. The receiver can then tell you the compass bearing, distance and once you start moving the speed at which you are travelling. A topographic map is still necessary to indicate hazards along the route.

There are some disadvantages in depending solely on the use of GPS receivers for navigation. The receivers do not work well under heavy forest cover especially if it is wet or covered in snow, or if used in deep valleys or gullies. In these conditions, the receivers have difficulty picking up satellite signals and without the data from three satellites, a location cannot be given. In addition, GPS receivers can be damaged if dropped, do not work well at low temperatures and the batteries can go dead. The elevation information from a GPS is so inaccurate as to make the readings useless. An altimeter has to be used if accurate elevation readings are required. Also, unlike altimeters, GPS receivers cannot give the barometric pressure which can be used to determine weather change.

GPS receivers definitely have some advantages that can be of benefit to SAR teams but in **no way should they replace traditional map and compass work for wilderness navigation.**

GPS and UTM Grid

GPS receivers can display your location as UTM Grid Coordinates. However, the number they display will not be the 6 figure grid coordinate that are commonly used by SAR Groups.

For example, the grid coordinates from a GPS receiver for the end of the logging road on Taite Creek (Figure 7.7) would be:

11U 0431125
5515400

The key is to know which figures to use to make the 6 digit grid reference.

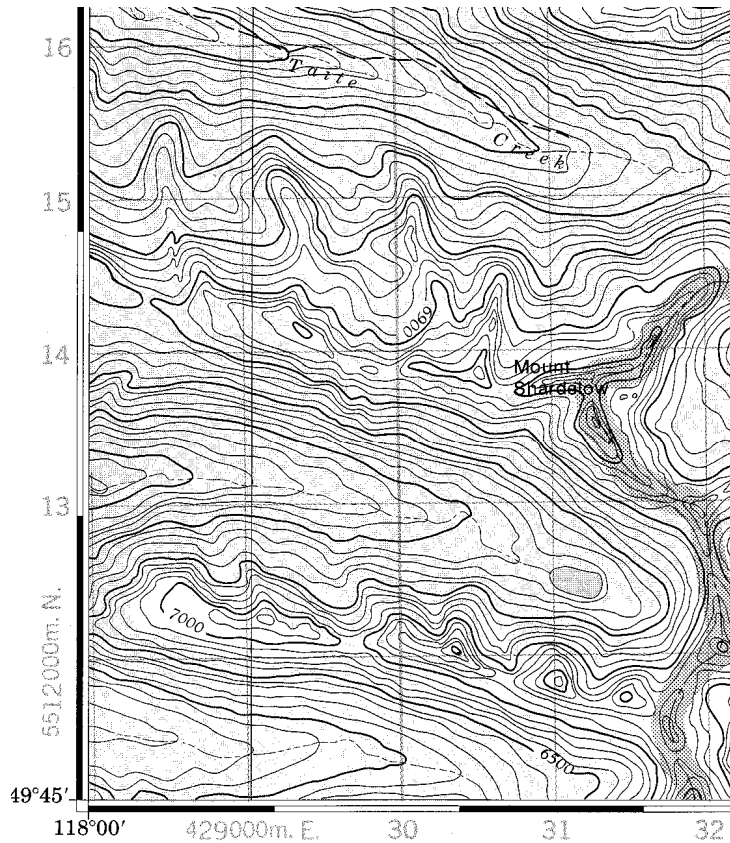

Figure 7.7 A UTM Grid Coordinate for the end of the road up Taite Creek from a GPS Receiver would be:

11U 0431125
5515400

To begin, the 11U refers to the map's grid zone. The grid zone for a map appears on the margin of the map (Figure 7.8).

GRID ZONE DESIGNATION: DÉSIGNATION DE LA ZONE DU QUADRILLAGE: 11U	100 000 m SQUARE IDENTIFICATION IDENTIFICATION DU CARRÉ DE 100 000 m <div style="border: 1px solid black; width: 80px; height: 40px; margin: 0 auto; text-align: center; line-height: 40px;"> MF </div>
---	--

Figure 7.8 Grid Zone Designation as it appears on the margin of a 1:50 000 map

The number on the top line after the grid zone designation is the easting coordinate while the lower number is the northing coordinate.

The easting coordinate (0431125) gives the east position down to the meter (remember GPS receivers are only accurate to within 100m due to selective availability). If you look in the corner of the map the full starting easting coordinate is given. In our example it is 429000 (Figure 7.6). Note that the 0 at the beginning of the easting coordinate is not put on the map. The larger 29 numbers indicate the grid line number for the grid line situated directly above the full number (429000). Therefore, as the end of the road is over from the 31 grid line, the 3 digit easting coordinate for the end of the road is 311.

The northing coordinate (5515400) is figured out in the same manner as for the easting coordinate. In this case the starting grid number for the map is 5512000 with the larger 12 indicating the grid line next to this number. As the end of the road is above the 15 line the 3 digit northing coordinate is 154.

To summarize, a reading from the GPS receiver of:

11U 0431125
5515400

becomes 311 154 in a six digit grid coordinate.

The conversion to a 6 digit coordinate can be easily done in the field by dropping the first two and the last two numbers off both the easting and the northing numbers.

Travel Skills

While conducting a search you may experience terrain that normally you would not think of travelling through. Terrain such as heavy brush, steep gullies, and swamps pose challenges to the searcher. Even on a relatively flat trail there are things that should be considered while travelling.

One thing to think about is your pace. On a SAR task with the adrenaline flowing through your body you tend to walk faster than you should. Remember, you may be walking for hours and you don't want to burn yourself out too soon. A moderate pace (not too slow) with short rest stops is the most efficient way to travel. Adjust your pace for the terrain. When travelling as a group, the pace should be adjusted for the slowest person, making sure no one falls behind. Putting the slowest person at the front of the group can set the pace and encourage the slow person to hike at a slightly faster pace. Ten minutes into the hike is a good time for an initial rest to adjust equipment and clothing. After that, a 5 minute rest every 1 hour to 1.5 hours should be sufficient.

Trails

Often a hasty search of trails is one of the first things to be done on a search. The search teams are sent along the trails to look for clues. Knowledge of the trails to be followed is a definite asset as more time can be spent looking for clues and less time spent looking for the trail. This trail knowledge is even more helpful at night when the trails are harder to follow. Time spent hiking and learning the local trails is an invaluable exercise.

If you are sent to search an unfamiliar trail and the objective is to follow the trail for a specific distance, make sure that you do not lose the trail. If you happen to find that you have lost the trail, stop, keep one person at the last position and have another person walk back and look for where the trail turned off. Keep within voice contact and if you have to work your way back to where the trail turned off, work as a group. Do not become separated.

Brush

Brush can be encountered in two different circumstances in SAR tasks. One is that searchers have to travel through the brush to the search area and the other is that a brushy area has to be searched.

If you are just travelling through the brush it is best to try and avoid it. Here are some ideas to keep in mind when avoiding brush. Travel on trails or roads even if the distance is longer. Travel in tall timber as there is less brush under the trees. Travel on ridges, straight up creekbeds, travel on snow, scree or talus or travel on game trails.

If you are required to search brush then you will have to go straight through it. Often by the time the dense bush is being searched all other high probability areas have been searched. Searching through dense brush is a slow difficult process. When searching through dense brush these suggestions might be helpful.

- Wear gloves especially for searching in areas of brambles or Devil's Club.
- Wear clear goggles to protect your eyes from being whipped by branches (this is especially important if searching brush at night when the branches cannot be seen).
- Make sure you see where you are placing your feet as there can be holes, water or even cliffs under the brush which cannot be seen.
- Make sure any loose equipment is securely attached to your body. There have been instances of pagers, radios and other types of equipment being knocked off in the bush that then required finding.
- Follow a compass bearing as it is very easy to lose your direction in the bush.

Talus and Scree

Often when searching in mountainous areas the searchers will come across talus or scree slopes. As mentioned earlier these slopes can provide brush free paths up mountains but they can also be quite dangerous if not stable. Talus or scree slopes often are in gullies or are at the bottom of cliffs. Talus is composed of rocks that are large enough to step on individually. While travelling up a talus slope it is important not to dislodge large rocks or rock avalanches onto yourself or onto other members of your search team. Keep close together when travelling as a group so no rocks gain momentum if they become dislodged.

Scree slopes are made up of small pebbles and rocks and are a couple centimetres in width. The size of rocks is usually quite uniform in scree with the rocks moving around your feet if stepped on. Movement of the rocks can make uphill progress on scree slopes very tiresome. Avoid hiking up scree slopes if at all possible. During downward descent use the movement of the rocks to help you descend. Again, if travelling as a group stay close together and try to avoid damaging vegetation on the slope, slope sides or bottom.

When crossing scree or talus slopes on trails it is important to locate where the trail leaves the slope and heads back into the woods. This is especially important at night. Many hours have been spent looking for trails on the edges of talus and scree slopes.

Snow and Glaciers

Snow is often encountered on searches in BC. Snow can make travel easier or it can make it difficult and dangerous. In soft snow other equipment such as skis or snowshoes are required to travel effectively. Their use will not be covered in this manual. Some of the hazards include cold, winds, avalanches, breaking through snow bridges across creeks, tree wells and crevasses on glaciers. Glacier travel requires special techniques which are beyond the scope of this manual.

Technical versus Non-technical Terrain

You are on technical terrain when special equipment or special techniques are required to move across an area. Examples of technical terrain include glaciers; mountains that require lead climbing; class 4 scrambling or repelling; swiftwater; caving; diving; and flat ice crossings.

It is important for SAR volunteers to know their limitations and that going into technical terrain requires more instruction and practice than is provided in the GSAR course.

Additional Resources

Graydon, Don, and Hanson, Kurt. *6th Edition, Mountaineering, The Freedom of the Hills*. Seattle, WA: The Mountaineers, 1997.

Kjellstrom, Bjorn. *Be Expert with Map & Compass*. New York, NY: MacMillan General Reference, 1994.

Seidman, David. *The Essential Wilderness Navigator*. Camden, MD: International Marine/Ragged Mountain Press, 1995.

Further references listed in the Bibliography.

Chapter Review

Please answer the following questions on a separate sheet of paper so that another student can use this manual. Use Figure 7.7 to answer the questions. The answers to these questions are located at the end of the manual.

1. What is the bearing looking from Pyramid Mountain to the Opal Cone? What is the back bearing?
2. You are in the Valley of Skookum Creek. Base wants to know what your location is. You take two bearings. The bearing on the east Gargoyle is 291° and the bearing on Pyramid Mountain is 32°. What is the UTM grid reference of your location?
3. You are on the trail by Elfin Lakes. You take a bearing on Pyramid Mountain and find that it is 67°. What is the latitude and longitude and the grid reference of your position?
4. What is one area of technical terrain on the map provided.

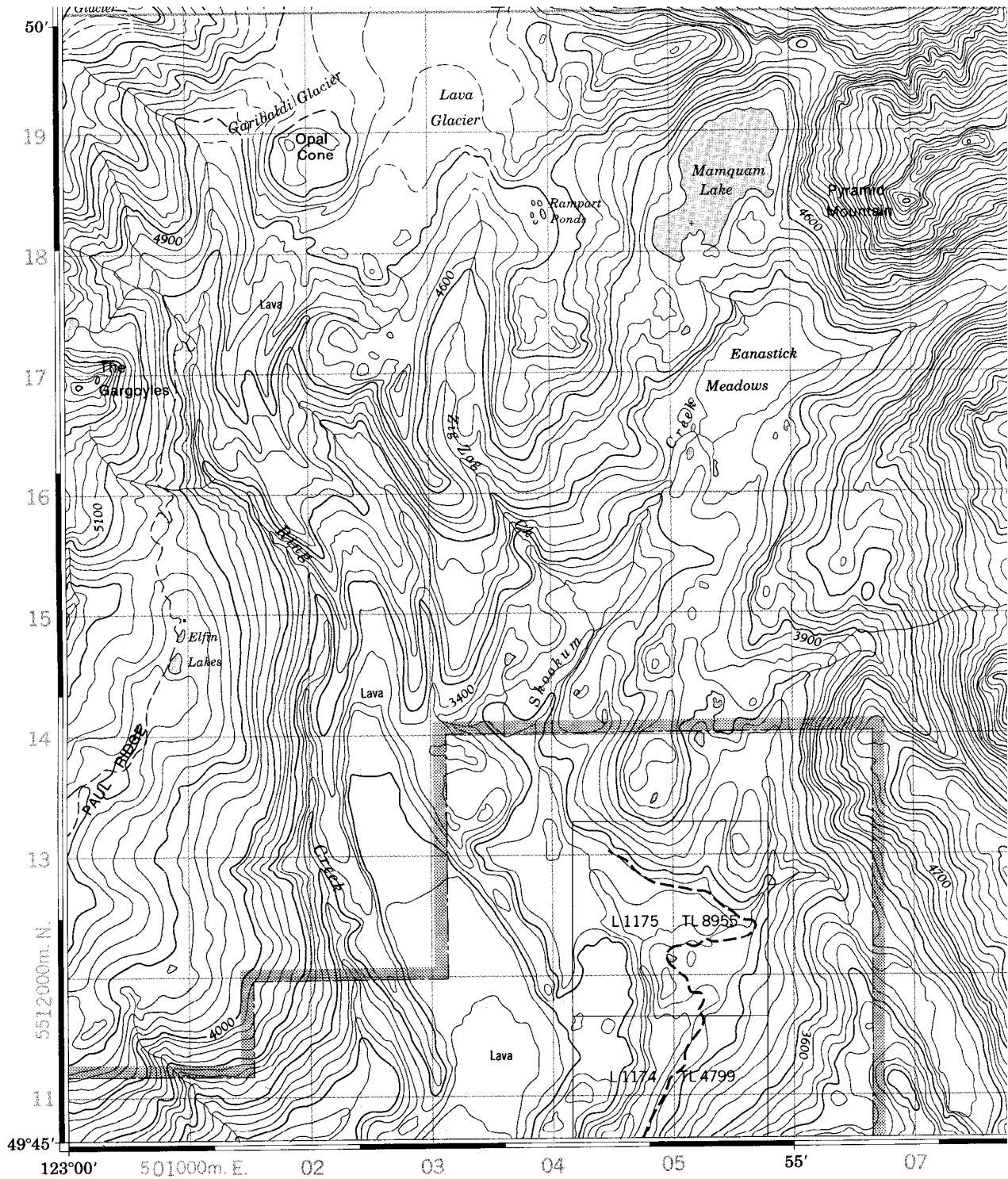

Figure 7.9 Map and Compass Exercise

Chapter 8 - Survival Skills

Upon completion of this chapter, you will be able to:

- Describe how a survival situation may be encountered on a SAR operation.
- Summarize some of the psychological problems associated with being in a survival situation.
- Explain ways how fear can be controlled.
- Define the “ Will to Live”.
- Explain how the survival situation plan “STOP” - Stop, Think, Observe, Plan can be used in a survival situation.
- Manage your energy budget when in a survival situation.
- Describe how the human body loses heat: by
 - a) Radiation
 - b) Conduction
 - c) Convection
 - d) Evaporation
- Discuss the prevention of hypothermia.
- Discuss the prevention of hyperthermia.
- Describe the function of each of the following layers of clothing:
 - a) Underwear Layer
 - b) Insulation Layer
 - c) Shell Layer
- Describe different types of outdoor footwear.
- Describe the importance of an adequate pack for SAR.
- Construct a 24-hour ready pack.
- Build, light and maintain a fire.
- Build a simple shelter.
- Perform different signal techniques for maximum visibility.
- Explain the physical needs for food and water.
- Identify possible sources of food and water when in survival situations.
- Explain the reasons for and describe methods of water disinfection.
- Describe correct procedures for personal waste disposal (how to shit in the woods).
- Defend the rule of staying put when lost and justify when travelling would be acceptable.
- Describe procedures for dealing with bears, cougars, and rattlesnakes.
- Discuss techniques for dealing with insects, ticks, rabies and Hantavirus.
- Demonstrate acceptable survival techniques in a supervised overnight exercise.

Introduction

An individual will not be prepared to participate in a wilderness search unless they are able to cope with at least some of the situations facing a missing person. In particular, the searcher should be able to stay in the wilderness for several nights should he or she become lost, injured or otherwise stranded. Knowledge of survival skills is essential for a person trained in GSAR.

Preparation and experience are vital keys to your survival. By having the right equipment and practicing under varied conditions on a regular basis you will be able to gain some of the essential experience that you or your team will need in a real life situation.

Preparation and practice will give you confidence and a psychological boost when you need it most.

You can read every survival book but it is not until you get “out there” that you will realize the full impact of a survival situation.

Practice is the key. Someone once said “He who dies with the most toys wins” however it should be noted that person still died. Having all the gadgets and survival toys in the world will not help if you do not know how to use them or have only used them in a sterile environment. You may be in serious trouble when you are put to the test.

Statistics point out that a majority of lost people are found going downhill in a streambed. Have you ever thought of going into a stream drainage area when there is a foot of snow on the ground, during a rainstorm, in the dark, with a wind blowing and practiced starting a fire or building an emergency shelter? This is not an unrealistic situation. Could you survive?

Remember **PEP=Survival**.

Practice + Experience + Preparation = Survival. Practice to gain experience and being properly prepared will make all the difference in your survivability.

The intention in this chapter is not to provide a complete treatment of all aspects of wilderness survival but rather to provide a brief summary of basic information relevant to a searcher when in a survival situation.

Survival Psychology

One important way of preparing for a survival situation is to simply anticipate it and know the types of personal reactions that may occur. Knowing what to expect can help to reduce the deleterious effects of some of these reactions.

Fear leading to **panic, anxiety, shame** and **despair** need no further description here. More importantly are the **weapons** that can be used to combat these emotions. These weapons include:

- Fear
- Knowledge and Experience
- Concentration
- Confidence in SAR
- The Will to Live (Positive Mental Attitude)

Fear

Fear itself can become a survival weapon if this powerful stimulus is controlled and channelled. It is not always the physically strong or happy-go-lucky person who most effectively handles fear. Timid or anxious persons may be the ones who respond well under stress resulting in a better chance of survival.

“No fear” often means “No brains” in a survival situation. It is OK to have a healthy respect and awareness of the seriousness and challenges of a situation. Controlled fear is controlled energy. Do not exaggerate the urgency of your situation but do not underestimate it either.

Knowledge and Experience

Knowledge and experience are extremely effective weapons. Knowing what to do to survive, how to facilitate a rescue and how to make life more liveable in the meantime cannot help but reduce fear and anxiety. Having confidence in one's own ability and equipment is vital.

Other weapons include **concentration** and **confidence in the SAR Team**. Concentrate on the job to be done without allowing one's mind to wander and visualize the worst. Have confidence in the SAR team, knowing that they are skilled and will do their utmost to remedy the situation as soon as possible.

Will to Live

The most important weapon of all in a severe survival situation is the **will to live**. This quality is impossible to explain, difficult to develop and varies from one person to another. It is why some people have survived for long periods of time in seemingly impossible situations, while others have perished in a relatively short time in survivable circumstances.

Enemies of Survival

The psychological problems discussed earlier can be exacerbated as time passes by other **enemies** of survival. Survival enemies include:

- Pain
- Cold
- Heat
- Thirst
- Hunger
- Fatigue
- Boredom and Loneliness
- Insects
- Predatory Animals

Pain can weaken the will to survive and can easily get the best of a person if it is allowed to do so. Knowledge and application of appropriate first aid is a good defence against pain as well as a **positively** occupied mind. Making special efforts to keep working and keep up hope are important ways of reducing the effects of pain.

Cold numbs the body, the mind and the will to survive. Cold can cause the desire for warmth and sleep and displaces the main goal of survival. Cold may be overcome by keeping physically busy and by lighting a fire and building a shelter.

Heat can lead to heat exhaustion or heat stroke. Heat can be overcome by resting during the hottest part of the day, staying out of the sun and getting enough fluids into your body.

Thirst, even when not extreme, can dull the mind and under no circumstances should a person be deprived of water unnecessarily. A strong will to survive can diminish the negative effects of thirst.

Hunger lowers the physical, and sometimes the mental, efficiency of the body. Thirst and hunger increase a person's susceptibility to the weakening effects of cold, pain and fear. Carrying survival rations is one way to reduce the effects of hunger in the short term.

Fatigue, in even a small amount, can reduce mental ability causing one to easily adopt the feeling of **just not caring**, leading to dangerous behaviour such as the reckless use of tools. Avoiding **unnecessary exertion** and maintaining a good mental attitude can delay the onset of fatigue.

Boredom and loneliness are two other tough enemies of survival. Once again maintaining a good mental attitude and keeping active are the best antidotes.

Insects may be extremely annoying and cause morale to drop. Protection with nets, smoke, or insect repellent can help in this respect. On many summer survival courses insects are the biggest complaint.

Predatory Animals

Problems with predatory animals are very unusual but fire can help keep them away.

With all these enemies the most important thing is being able to recognize when they are occurring.

“STOP”

One way to deal with the mental problems in a survival situation is to **STOP** (Stop/Think/ Observe/Plan).

If you find yourself in an emergency or survival situation the first thing to do is to **STOP** moving. Rushing around can increase anxiety and will make you more confused. In this state, decisions are made with no forethought and actions do not follow a logical plan. Once you have stopped moving you can **THINK** about the actions that can be done to improve your chances of survival. While you are thinking you can look around and **OBSERVE** your situation. Look for immediate hazards or resources you can work with. Finally after thinking and observing you can **PLAN** your actions in a deliberate practical manner.

Energy Budget

It is also important to remember that in a true survival situation there is an energy budget. Every action, such as travelling, shelter building or gathering food, uses up energy reserves and these reserves are limited. Therefore, before an action is carried out it should be decided that the benefits of that action outweigh the disadvantage of the energy loss.

Survival Qualities

Weather, terrain and the nature of an emergency have important effects on survivability, but even more important can be the qualities of the person trying to survive. A list of the desirable qualities includes:

1. Hoping for the best, but preparing for the worst
2. Decisive
3. Can improvise
4. Can live with himself/herself and with others
5. Is patient
6. Can adapt to situation
7. Can control his/her fears
8. Can remain cool, calm and collected
9. Can endure setbacks without being discouraged
10. Is mentally and physically prepared
11. Knows the survival pattern and uses it.

Equipment and Clothing

When a GSAR member responds to a call there is always the chance that it will turn into an overnight or a longer stay in the wilderness. The GSAR member should be hoping for the best but prepared for the worst. This means on every call the GSAR member should be carrying the appropriate equipment. This equipment includes the clothing you wear and the 24 hour ready pack which you carry.

Each of us is a heat producing organism that depends upon clothing and shelter for protection from temperature extremes. Our bodies have to be protected from losing too much heat (hypothermia) and from gaining too much heat (hyperthermia).

Hypothermia

Hypothermia is a drop in the core body temperature to a level at which normal muscular and mental functions are impaired. The first symptoms of hypothermia are:

- Shivering
- Deterioration in mental functions (responses are slow or inappropriate)
- Stiff and clumsy fingers

More severe hypothermia includes

- More “umbles” Stumbles, mumbles, fumbles, grumbles
- Apathy
- Slurred speech, Confusion
- Shivering stops
- Incoherence, disorientation and irrationality

Prevention of hypothermia is simple while treatment is not. The following discussion focuses on prevention and does not include treatment.

Hypothermia Prevention

Hypothermia is one of the most frequent causes of death in the mountains. It is just as prevalent in damp, moderately cool environments as it is in cold environments. Knowledge of how heat is lost from the body will be helpful in preventing hypothermia.

Heat is lost from our bodies in 4 ways: conduction, radiation, convection, and evaporation. Conduction is the loss of body heat through body contact with colder objects. This type of heat loss is especially important when sitting or lying on the cold ground, ice or snow. It is therefore important to insulate your body from the cold ground with an insulating material such as a closed foam pad or more commonly in SAR operations your pack and extra gear. In addition, when clothing gets wet it conducts heat away from your body 25 times more quickly than dry clothing. Avoidance of getting wet and putting on dry clothing is critical in prevention of hypothermia.

Radiation is the loss of body heat as the body emits infrared radiation from exposed area of skin. An exposed head can radiate up to 50% of the bodies heat loss. Wearing a hat can prevent most of this loss.

Convection is the loss of body heat as air currents replace the warm air next to our body with colder air. The body then heats the colder air losing that heat. Getting out of the wind and wearing clothing that prevents air movement around the body are ways to prevent convection heat loss.

Heat is lost from the evaporation of water either through perspiration or through respiration. Most of the heat loss is through perspiration with a minor amount of heat loss occurring because of respiration. Perspiration into clothing should be avoided as once the clothing is wet it loses its' ability to prevent heat loss. If heading up the trail remove extra clothes early to prevent them from getting wet. **Once you have stopped remove any wet clothes and put on your extra clothing before you feel chilled.**

Hyperthermia

On hot days hyperthermia (heat exhaustion leading to heat stroke) has to be prevented by wearing loose fitting light coloured clothing and remembering to shade the head and the back of the neck. In extremely hot environments exercise should be limited and resting during the hottest part of the day may be appropriate. This is especially important in people who have not acclimatized to the hot environment.

Proper fluid intake is extremely important in the prevention of hyperthermia with most people not drinking enough fluids. Forcing yourself to drink more liquids than you think you need is necessary for proper hydration.

Clothing

Every individual's metabolism is different as is everyone's tolerance and comfort levels. For this reason, the best way to regulate body temperature is with the layer system. With this, a number of easy on/off layers of clothing are used rather than one large and heavy garment. The layers are treated as:

The Underwear Layer

While the underwear layer provides some insulation, its primary function is to control moisture next to the skin. Keeping the clothes next to your skin dry is the key to staying warm.

Rather than absorbing moisture like the natural fibres, polyesters and polypropylene work by repelling water away from the skin surface. To function properly it must be thin and in close contact with the skin surface. In some products, a small percentage of Lycra has been added to maintain a close fit.

**Insulation (clothing)
Layer**

This layer should offer insulation while absorbing and transferring outwards the moisture passed from the underwear layer beneath. The trapped air in the clothing layer provides the insulation. It should fit comfortably, not too tight, and dry quickly. A variety of zippers offer alternative methods of ventilation to prevent moisture build-up without actually removing the entire garment.

With very little exception, thickness means warmth. However, wearing many thin layers offers more warmth than one thick layer. By varying the selection of materials in this layer and using a number of garments in the layer, a variety of temperatures can be accommodated. Materials in this layer include wool, fleece, pile and occasionally down.

Wool

Wool is warm when wet and does not wick moisture. Wool will absorb 30% of its weight in water and still retain heat. Wool should not be washed too often as this removes the water repellent oils.

Polyester

Polyester (fleece, pile) is a good insulator, remains warm when wet but has relatively poor wind resistance. Some type of wind proof outer layer is required for fleece or pile to be a useful insulator. In addition, care has to be taken around fires as sparks will melt polyester clothing. Wool is a better choice around fires as it is more flame resistant.

Down

Down has extremely good insulating properties and is a good choice in very cold, dry conditions. However when it gets wet it is a very poor insulator and it takes a long time to dry. Therefore it is not the best choice when physically active or when there is a chance it will get wet.

Cotton

Cotton has no place in poor weather as it provides no insulation when it gets wet. Cotton is suitable for warm or hot days as it is very comfortable and provides protection from the sun. Alternate clothing must be available in case the weather changes.

**The Shell (outer)
Layer**

The shell layer is what actually protects the wearer from wind, sun, rain, snow etc. Waterproof materials can cause condensation under the shell while protecting against outside moisture entry. Non waterproof materials allow the wearer to get wet while allowing inside moisture to escape.

A material providing as much waterproofness as possible while allowing interior moisture to escape is the best compromise for an exterior shell layer. Although the ratios between waterproofness and breathability vary, some of these materials include; Goretex, Sympatex, Quarapel, Stormshed etc. No material will keep the wearer totally dry if vigorous activity is performed in wet conditions. Ventilation has to be carefully managed to prevent the build up of moisture from perspiration.

Footwear

While a balance between waterproofness and breathability is critical for high exertion work such as ascending mountain trails, a case can be made for staying absolutely dry. Oftentimes searchers or rescue personnel spend a long time out in the rain or snow not moving very fast. Such assignments might include confinement teams, lookouts or open grid searches through moderately dense wet bush.

Instead of looking to high tech recreational equipment look to an industrial supplier. What do forestry workers, public works and fisheries workers wear under similar circumstances with similar activity levels. They use neoprene, PVC or coated nylon raingear not Gortex or Quarpel. Whatever type of waterproof clothing is purchased it should fit loose to allow some venting.

The selection of appropriate footwear can vary depending on the conditions. Leather hiking boots are good for searching through the woods and alpine areas while plastic boots are more appropriate for more technical conditions in snow and ice. Felt packs with rubber bottom sections and leather uppers are the best for less technical terrain in snowy, cold conditions. Rubber boots are a viable option for searching through swampy areas where your feet will constantly be in water.

Good quality hiking boots with leather uppers and vibram soles are the best footwear for many situations in SAR, but must be looked after properly, including regular waterproofing. If the boots do get wet and need drying by a fire, great caution should be exercised. The boots should be placed upright and should never be closer to the fire than a position that is warm to the hand. They should be turned periodically so they **dry slowly**. Under no circumstances should they be left unattended.

If boots cannot be dried completely, wearing a dry pair of socks will help. Felt packs have to be maintained properly as dirty leather or synthetic uppers will allow snow to stick and the melt water to run down into the boot. Cleaning and waterproofing will prevent this.

The combination of socks most commonly worn is a wool outer sock with a synthetic liner sock against the skin. An extra pair of wool socks should be carried in your pack and if the conditions are very wet two pairs of dry socks should be carried.

Blisters

Blistered feet can become a serious problem, even with boots that fit well. "Moleskin" (or an equivalent product such as Kurotex), or duct tape **used at the first sign** of a problem is an effective way of controlling blisters.

Once a blister has started, moleskin should not be applied directly onto the blister. The moleskin will pull the blister apart. An effective way to deal with a blister is to cut a donut out of moleskin and place it around the blister. Make sure the moleskin is thick enough to prevent any pressure on the blister. If it is not thick enough add another donut of moleskin to the first layer applied. Tape the moleskin in place to prevent it from shifting.

TREATING HOT SPOTS AND BLISTERS

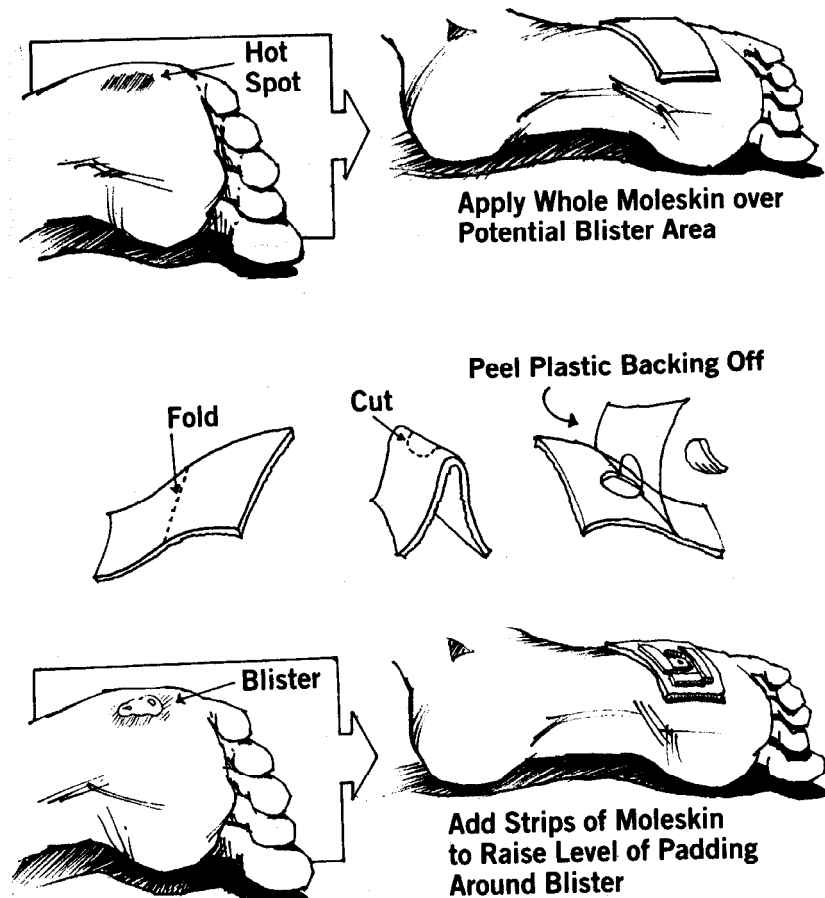

Publisher: Simon & Schuster, Inc. Author: P. Simer, J. Sullivan Title: The National Outdoor Leadership School's Wilderness Guide
© This material has been copied under licence from CANCOPY. Resale or further copying of this material is strictly prohibited.

Figure 8.1 Care of Blisters

Gaiters

Gaiters are a useful accessory to keep excess water and debris out of boots and are invaluable in **snow** and **insect** country. These are especially useful in preventing ticks from getting onto your legs.

Head and Hands

Since a large percentage of body heat loss can occur through the head a hat, toque, hood, or balaclava is an important addition to your pack. Hats also provide protection against heat in hot climates and against sun exposure to the top of the head and face. A bandanna can also be useful in protecting the head and neck from the sun either by itself or in combination with a hat.

Mittens or gloves should be carried to protect the hands from the effects of cold weather. Mittens keep the hands warmer than gloves but gloves allow for more dexterity. A combination of gloves with overmittens for very cold weather might provide the best attributes of both.

Ready Pack

Whenever a person participates in a wilderness search, he or she should be prepared to be **self-sufficient for at least 24 hours**, regardless of conditions. GSAR team members should keep a pack loaded and ready to ensure the ability to respond to a call quickly. Remember, that being prepared for a task in the summer will be different than being prepared for a task in the winter.

Never travel without your pack. There is a tendency to get the people into position using helicopters, snowmobiles or vehicles and bring in the gear on a later trip. If the weather closes in and the helicopter can't fly, you may be in for an interesting night if you left your pack behind.

It is imperative that all GSAR members have personal equipment ready to go at all times. Keeping a ready pack "ready" is often a struggle for SAR volunteers as their gear is used for other activities besides SAR. However, once the pager goes off or the call comes in, time should not be wasted hunting for gear.

Keeping in mind the procedures described in this chapter, the following list of **personal** equipment is recommended for all people involved in SAR and should be carried with them on any wilderness search:

- Plastic tarp or shelter (3 m x 4 m)
- Water proof clothing bag (2 large orange plastic garbage bags)

Spare clothes:

- Wool or pile toque
- Wool or pile mitts
- Wool socks
- Wind and waterproof coat and pants
- Wool or pile coat
- Some additional clothing for the subject

Equipment

- Fire starter (matches, lighter and candle)
- Food
- At least 1 L of water (2 L if there is no dependable water source), water container and some way to purify the water
- Pot with a lid
- Rope (15 m light nylon)
- Knife
- Declination adjustable compass
- Headlamp plus extra bulb and battery
- Pad and pencil
- Map
- Toilet paper
- Personal first aid
- Insect repellent
- Sunscreen
- Whistle
- Watch
- Sunglasses

Other useful items which could be included are:

- Folding saw
- Altimeter
- Emergency blankets
- Flagging tape
- Scissors
- 3-5 m light wire
- Clear eye protection for searching bush at night
- Sleeping bag
- Lightweight stove and fuel
- Pencil flares
- 2-12 hour light sticks
- Duct tape
- Food
 - Semisweet chocolate
 - Soup cubes
 - Protein bars
 - Hard sugar candy
- Booklet on wilderness survival

First Aid Equipment

Recommended minimum basic supplies; to be contained in each members kit in a small waterproof package:

- 10 cm x 5 cm pressure bandage
- (6) 10 cm x 10 cm gauze pads
- 7.5 cm x 5 m. "Kling" gauze roller bandage
- 2.5 cm adhesive tape
- (6) Elastoplast (recommended) bandaids
- latex gloves
- triangular bandage
- moleskin or equivalent product
- A piece of drinking straw and thread for tick removal, small container for taking the tick to the local health unit.
- Pocket mask for artificial respiration or CPR

Any other items of personal need or desire may be added, e.g. sting stop, ASA, allergy medication, etc.) Other items may also be desirable depending on the circumstances of the search.

Survival Pattern

Being prepared with the correct clothing and equipment on a SAR task is the first step in surviving an emergency situation. Knowing the survival pattern is also important in increasing the odds of survival. The **survival pattern** is the order in which the necessities of life are acquired. The pattern is:

1. First Aid
2. Fire
3. Shelter
4. Signals
5. Water
6. Food

The following sections will discuss the methods of instituting the survival pattern. First Aid will not be discussed, but in no way should this omission minimize the importance of First Aid as the first step in the survival pattern.

It must be added that the order of **Fire** and **Shelter** in the above pattern does not meet with unanimous agreement among experienced outdoors people. There is no question that circumstances do exist where this order should be reversed. For example, if it is raining heavily, finding shelter quickly is likely to be much more beneficial than what may be futile efforts to start a fire. In the discussion that follows, Fire will precede Shelter, but the need to use common sense in determining the order is vital.

Improvisation

In a survival situation the equipment may not be available to provide for the necessities of life. This is where the ability to improvise and adapt to conditions is extremely important. A lack of imagination can directly impact your survivability. Being able to use whatever equipment you have available along with what is available in the local environment to provide for the necessities of life can make the difference in a survival situation. Having a desire to live, focussing on what has to be done, keeping an open mind about how things can be done and using whatever is available are the keys to survival. If you are with your search team (which you should be on a SAR task) then discussing your survival options with your teammates can open up new opportunities that no one had thought of by themselves.

If you have only one hour of daylight left and you are forced to use what mother nature has provided you are going to be very hard pressed to gather enough fuel, build a fire and construct a suitable shelter before dark sets in.

Fire

Fire is a basic element of survival procedure no matter what time of year. It is the difference between life and death in the winter. It can be used for:

- Providing essential **warmth**,
- **Drying** clothing,
- **Cooking** food,
- **Signalling**,
- **Melting snow** or **boiling** unsafe water,
- **Keeping animals away**.

As important as any of these practical uses, is the **boost** given to the **morale** of the person in distress when a good fire is obtained.

Before building a fire, it is important to find a suitable location. If the fire is to be used in conjunction with a shelter, then the position relative to the appropriate shelter site is vital. The location should be **sheltered** from wind and what wind there is should not blow smoke straight into the shelter.

If possible, the fire should be built on a **mineral soil** (sand-gravel) **base** to prevent the fire spreading underground. If there is snow on the ground, then it is best to dig down to solid ground, making sure to clear a wide enough area to provide adequate ventilation for the fire. If digging is not practical, then providing a **base of green logs** will stop the melted snow from extinguishing the fire. Setting a **fire under trees is not recommended**. There is a danger of setting the tree on fire in all but the wettest times of year. If there is snow on the branches, the heat from the fire may cause it to drop, burying the fire, shelter and possibly the victim.

A supply of **water or sand** should be kept close to the site if there is the remotest possibility of the fire starting to spread. The fire should **not** be built **in a depression**. Heavy rainfall could result in water accumulating and extinguishing the fire, as well as it being difficult to push logs into the hot coals. The fire should be close enough to the shelter to provide some warmth, but not so close as to risk setting fire to it. A bank of big logs on the side of the fire opposite to the shelter will help **reflect** heat into the shelter. However, the amount of heat reflected back is minimal with the main advantage being that the logs making up the reflector can be drying. If ringing the fire with rocks, do not use porous rocks or rocks that have been in water as there is a danger of a rock exploding when heated.

It is also useful to position you and your shelter between the fire and a rock face. The rock face will radiate heat back keeping you warmer.

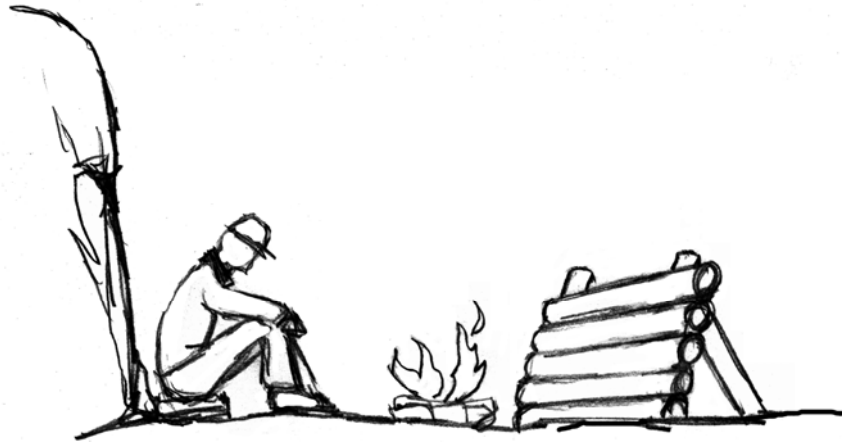

Figure 8.2 Fire Location

Provided that a suitable site for the fire has been chosen, successful fire lighting has four requirements. The basic elements of lighting a fire are:

1. Spark
2. Tinder
3. Fuel
4. Oxygen

The **spark** is needed to initiate the fire. Matches (preferably an abundant supply of waterproof/windproof strike anywhere matches stored in a sealed container) are the most likely spark source, but a lighter, magnesium starter blocks, striker starter, or flint and steel are also common and reliable sources. Other more exotic techniques are described in books on survival training but these other techniques take a lot of time, practice and energy to master.

When choosing matches there is the good, the bad and the ugly. Good matches are strike anywhere matches (may be difficult to locate), the bad are waterproof, hurricane matches (they require a striking surface that becomes unusable if wet) and the ugly are paper matches (should not be used in SAR).

The spark is useless without **tinder** to ignite. Tinder must be **dry, fine and highly inflammable**. Suitable material include:

1. Cotton fuzz (scraped from clothing)
2. Paper fuzz
3. Absorbent cotton (first aid kit)
4. Dead, dry grasses
5. Fine amounts of dry bark such as birch or cedar
6. Granulated pitch from stumps
7. Commercial fire starters or candles
8. Sections of used bicycle inner tubes

Most types of tinder **readily absorb moisture** so it is very important to keep tinder in a dry place. **Fuel** for the fire is needed in **large amounts**, and a good supply should be gathered before starting the fire. Enough fuel should be collected to last the night as searching for firewood at night is to be avoided. Collect 2 to 3 times more wood than you think you need.

Kindling is the first fuel to be ignited by the tinder and it must be small and dry. Dead wood that is still standing is the best source. In very wet weather, the best place to look is the lower dead branches of living evergreens. Tiny, **brittle** branches no thicker than a pencil lead will nearly always burn well. Test for dryness on pine trees by bending the branch, if it snaps it is dry, if it bends then snaps it is partially dry and if it bends without snapping it is still wet. Some wood should be split into kindling and **feather sticks** may be made to improve the ease of ignition. Feather sticks are dry sticks shaved on the sides in a fan shape. Kindling is replaced by more substantial fuel once the fire is going. Softwoods are usually easier to ignite but hard woods burn hotter. The final requirement for a fire is **oxygen**. The fire must be **well-ventilated** to ensure an adequate supply of oxygen.

To light the fire, the tinder should be arranged so the heat from it rises through the maximum amount of kindling. Arranging the kindling in a tepee shape over the tinder is best. As the kindling begins to burn, the next larger sized pieces of fuel should be added and so forth. Start with the driest wood available and use the greener wood (or wet wood) after the fire is going. A **common mistake** is to smother a new-lit fire by adding **too much fuel too soon**. Other common problems are:

- Poor selection of tinder and fuel.
- Failure to shield match from wind.
- Lighting fire from downwind side.

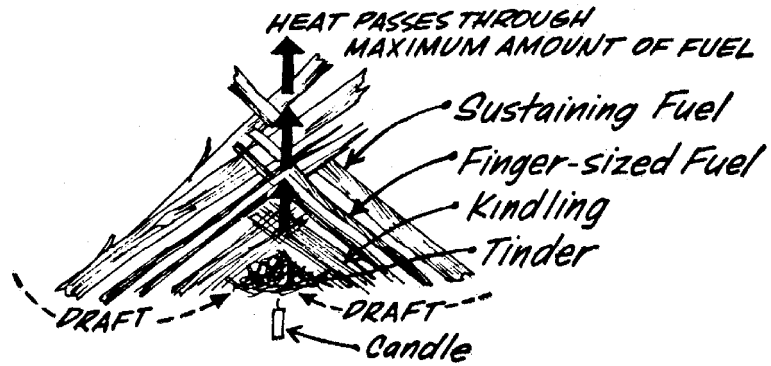

Publisher: Survival Education Association Author: G. Fear Title: Surviving the unexpected Wilderness Emergency
© This material has been copied under licence from CANCOPY. Resale or further copying of this material is strictly prohibited.

Figure 8.3 Tepee Fire

While a strong wind can be a serious problem, a gentle wind will improve ventilation and enhance combustion. Blowing gently into the fire when starting it is another way of achieving a similar effect.

The need for a large supply of good firewood cannot be over emphasized. Dry firewood may be easy to find in the middle of summer however when it is raining or there is snow, it becomes more difficult. Places to find dry wood include:

- Standing dead trees.
- The bottom side of trees that have fallen over but do not touch the ground.
- Higher up a slope away from creeks that often have very moist environments.
- Inside hollow tree stumps.
- Under rock overhangs.
- Within the exposed root systems of blown over conifer trees (roots contain high amounts of pitch).
- Within slash piles.
- Within clumps of willow or maple brush where stems have died or broken off and have become lodged upright.
- By splitting firewood, the inside should still be dry.
- In deep snow, digging down to the base of a tree will uncover dry wood.

Chopping logs into short pieces is a waste of energy so either feed the end of a log into the fire until the whole log is consumed or put the middle of the log onto the fire and burn it into two logs. Setting aside adequate tinder and kindling for the next day and ensuring it remains dry is absolutely vital. The most vital thing of all is **making sure the fire is out when leaving.**

Shelter Building

After necessary first aid has been applied and a fire has been established, the third step in the survival pattern is providing a shelter. A shelter is essential protection against the elements at all times of the year. It also provides a place for drying and storing equipment and firewood and together with the fire can make an excellent signal for airborne searchers. Not to be underestimated, is the psychological lift of having a "home". In extreme environments it is also wise to carry some sort of extra equipment such as a bivi shelter or tent. However, knowledge of building other types of shelters is important.

A good shelter site will have a **good supply of firewood and building materials nearby**. Also nearby should be a **water supply**. For ease of spotting, an **open area** is most desirable, but if protection from the elements makes this arrangement unsuitable, there should be a clear area nearby for making signals. A campsite in the trees is very hard to detect from the air. The proximity of food resources should be considered but is not a high priority. There are a number of situations to be avoided in selecting a shelter site. It **should not be:**

- In the possible path of falling rocks, landslides or avalanches.
- Under dead trees or large dead branches of living trees.
- In an area that could be flooded with a heavy rainfall.
- In swampy or tidal terrain.

Other factors include, having as **level** an area as possible, an area where the **base for a fire is suitable** and considerations about the strength and direction of the prevailing wind. In winter, protection from the wind is desirable, but in summer the wind can assist in keeping away flying insects. All other things being equal, a **pleasant view** can be of psychological benefit.

A shelter should be kept small and dry with a **minimum amount of energy expended to build it**.

Naturally Occurring Shelters

Do not overlook the use of naturally occurring shelters such as caves, downed trees, large rock overhangs, debris piles or boles of trees. If these are not available then there are many types of shelter that can be constructed. Bush lean-to's, tepees, domed shelters, snow caves, quincies, and igloos are but a few examples. A complete treatment of the various arrangements is impossible in this brief overview. The types of shelters discussed in this chapter include a lean-to with a polyethylene roof, double lean-to, parachute tepee, snow trench, tree wells and snow caves. Details of other types will be found in books on wilderness survival.

Lean-to Shelter

Construction of a plastic lean-to requires a sheet of polyethylene about 3 m x 3.5 m (10 x 12 ft), a ball of strong string, a sharp knife and preferably, a small saw. It is easiest if **two trees**, no more than 20 cm in diameter, can be found with a **space of approximately 2.5 m** between them. The location of these trees should be aligned at 45° to the prevailing wind so the wind will not blow into the lean-to but will provide ventilation for the fire and keep the smoke away. Figure 8.3 illustrates the possible arrangements.

A lean-to without a fire is a cold shelter.

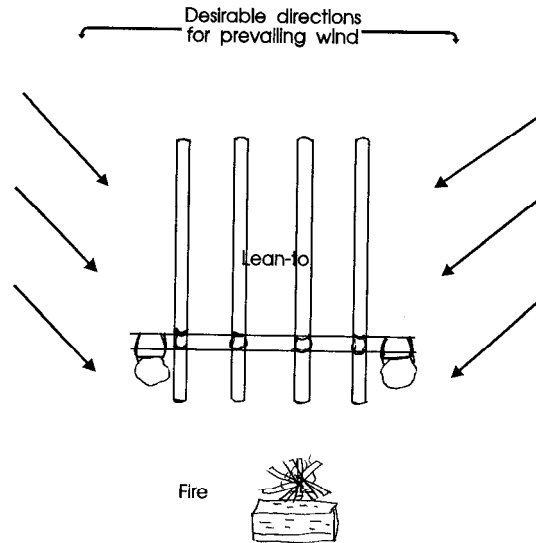

Figure 8.4 Lean-to Orientation

A **ridgepole** for lashing between the trees is the next requirement. This pole should be 5-10 cm in diameter and long enough to project slightly beyond each of the two trees selected earlier. It should be lashed to the trees on the side opposite to the fire and should be chest-high or less for a one-person lean-to and shoulder-high or less for a two-person lean-to. Three or four roof poles are required. These poles should be long enough to reach from the ground at the back of the lean-to to as much as 1 m beyond the ridgepole. They should slope at about a 45° angle. Figure 8.4 illustrates the general arrangements of the frame of the lean-to.

Once the lean-to frame is complete, the plastic should be laid over the roofpoles and securely fastened down. As the plastic can be easily punctured it is important that the roofpoles be as **smooth** as possible. Holes should not be made in the plastic for attachment purposes. The ends of the plastic should be **wrapped around logs** to hold the back and sides in place. Where strings must be attached it is best to insert a small stone in the plastic and tie the string securely around it.

The plastic should be kept **taut** to avoid pockets where water can collect and to minimize flapping in the wind. It is desirable that the plastic forms sides on the lean-to as well as a back in order to keep in the heat from the fire and keep out the wind. Practising building a shelter of this type is the best way to understand the problems involved and how to overcome them.

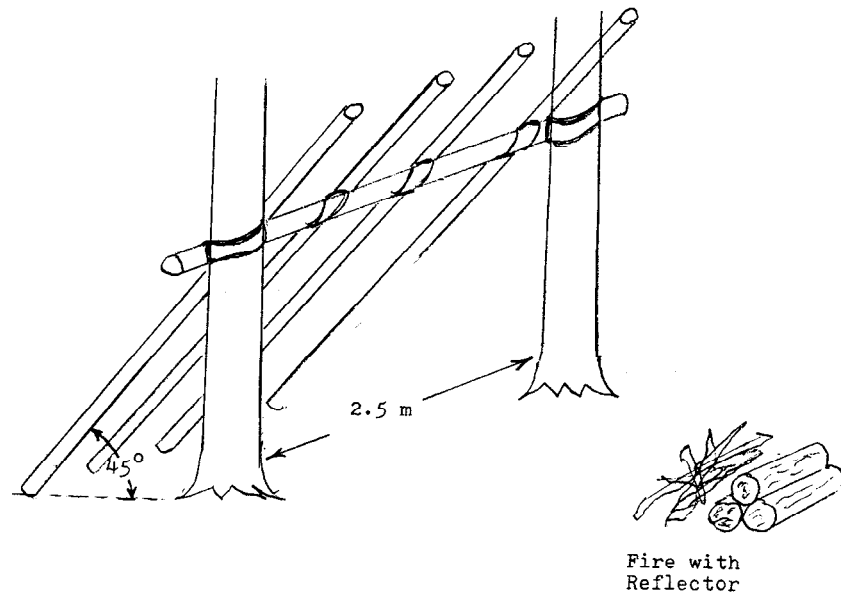

Figure 8.5 Lean-to Frame

The floor of the lean-to should be covered with a thick bed of green boughs from evergreens. A thick layer of larger branches should be placed on the bottom and a second layer of smaller branches on top. This bed of boughs serves three purposes:

- It insulates the occupant from the cold ground.
(Remember that heat loss from conduction to the ground can be very significant).
- It makes it more comfortable for sleeping.
- In the event of hearing an aircraft it provides a quick means of generating a lot of smoke through putting the green boughs on the fire.

For environmental reasons, making the bed of green boughs should **only** be done **in a genuine emergency**.

Two other modifications can increase the warmth in the shelter. One is placing a space blanket between the roofpoles and the plastic on the back of the lean-to so that the aluminum side faces the fire. This arrangement will reflect more heat into the lean-to. The other modification is to have the plastic overhang part way down the front of the lean-to after it crosses the ridge pole. This will trap more heat in the lean-to.

Double Lean-to

A double lean-to is made by facing two simple lean-to together with a space in-between for the fire. Special consideration should be made for wind direction. The wind should be blowing down between the shelters and not across them.

Parachute Tepee

A parachute tepee can provide a quick, easy shelter to get out of the rain. A parachute tepee is constructed by:

- Place a fist sized rock in the middle of your piece of plastic
- Wrap the rock with the plastic and tie with rope.
- Suspend the rock and plastic from a tree branch forming a tepee.
- Peg down the edges of the plastic.
- In windy or rainy conditions a doorway should not be cut (Figure 8.5).

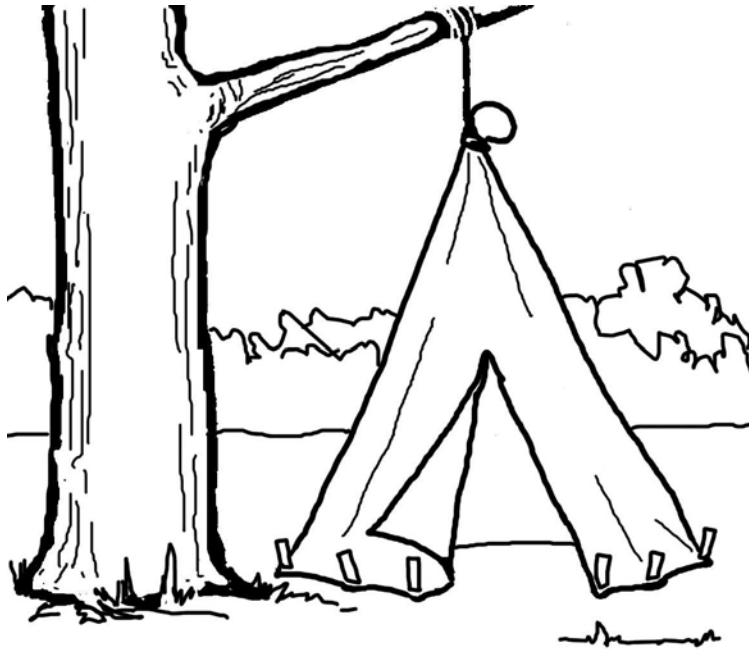

Figure 8.6 Parachute Tepee

Winter Conditions

In winter conditions more protection from the elements may be needed than the simple lean-to provides. To construct many of the winter shelters a shovel is required and an ice saw may come in handy. Remember to insulate the living area from the snow with bark, boughs, limbs or equipment.

In an emergency situation the quickest shelter that provides the best protection from the elements with the least energy expended in its' construction should be used. For winter conditions this would be a snow trench or tree-pit shelter.

Snow trench

A narrow trench is dug that is 1-2 m deep and is as long and wide as is needed to fit one or two people. It is either roofed with plastic tarp or snow blocks. If a plastic tarp is used it should be sloped and its' edges weighted with snow (Figure 8.6). Be aware that heavy snowfall can collapse the roof.

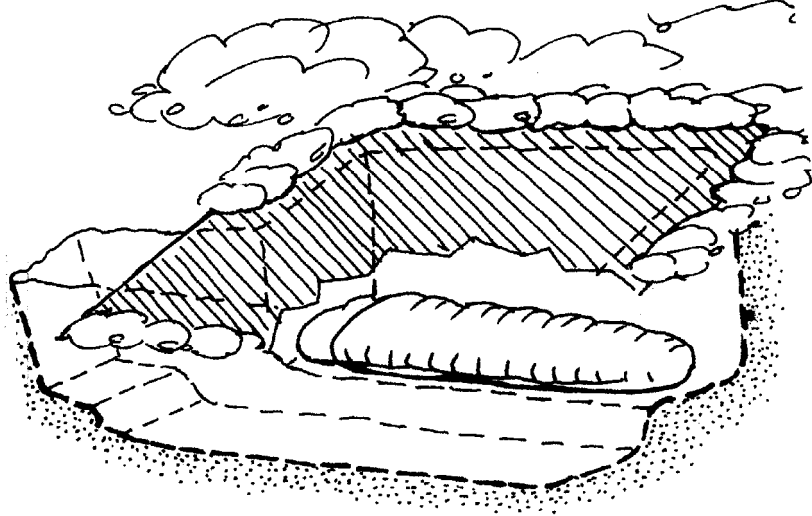

Publisher: The Mountaineers Author: D. Graydon, K. Hanson Title: 6th Edition – Mountaineering The Freedom of the Hills
© This material has been copied under licence from CANCOPY. Resale or further copying of this material is strictly prohibited.

Figure 8.7 Snow Trench using Plastic Tarp

If snow blocks are used for the roof they can be cut when removing the snow for the trench or they can be quarried nearby. Once the trench is dug make a ledge around the top edge of the trench. The snow blocks are placed on top of the ledge and angled over the trench forming an A-frame style roof. Fill the cracks with snow and cover the windward end of the trench with another block (Figure 8.7).

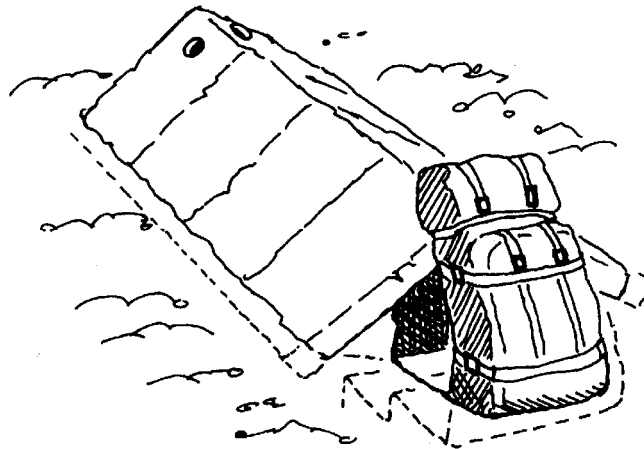

Publisher: The Mountaineers Author: D. Graydon, K. Hanson Title: 6th Edition – Mountaineering The Freedom of the Hills
© This material has been copied under licence from CANCOPY. Resale or further copying of this material is strictly prohibited.

Figure 8.8 Snow Trench Using Snow Blocks for a Roof.

Tree Well Shelter (Tree-Pit Shelter)

If you are in a wooded area where there is deep snow, the area around tree trunks already have spaces that can be enlarged into shelters. Before starting, knock down any large accumulation of snow sitting on branches that may fall onto your shelter. Dig around the base of a tree and especially under spreading boughs that are buried in the snow. If necessary roof the pit with snow blocks, boughs or plastic. Insulate yourself from the snow.

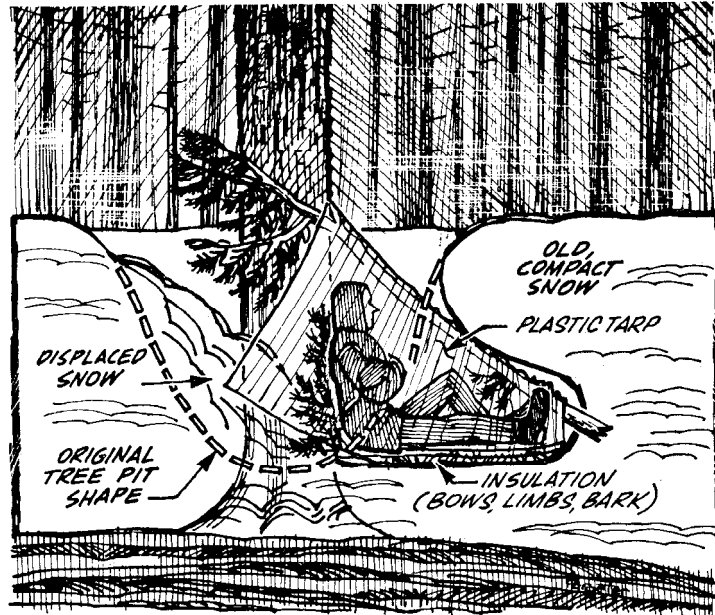

Publisher: Survival Education Association Author: G. Fear Title: Surviving the unexpected Wilderness Emergency
© This material has been copied under licence from CANCOPY. Resale or further copying of this material is strictly prohibited.

Figure 8.9 Tree-Pit Shelter

Snow caves

Snow caves take considerable more time to build than a snow trench (up to 3 hours) and care must be taken not to get too wet while building one.

To build a snow cave you dig into a snow bank or drift and hollow out a cave. The entrance should be lower than the cave and a ledge should be built inside the cave to sleep on. Push a hole through the roof to allow for ventilation. Smooth the surface of the roof so that water will run down the sides of the cave.

In an emergency situation it is better to dig a snow trench or build a tree well shelter than expend the considerable energy building a snow cave.

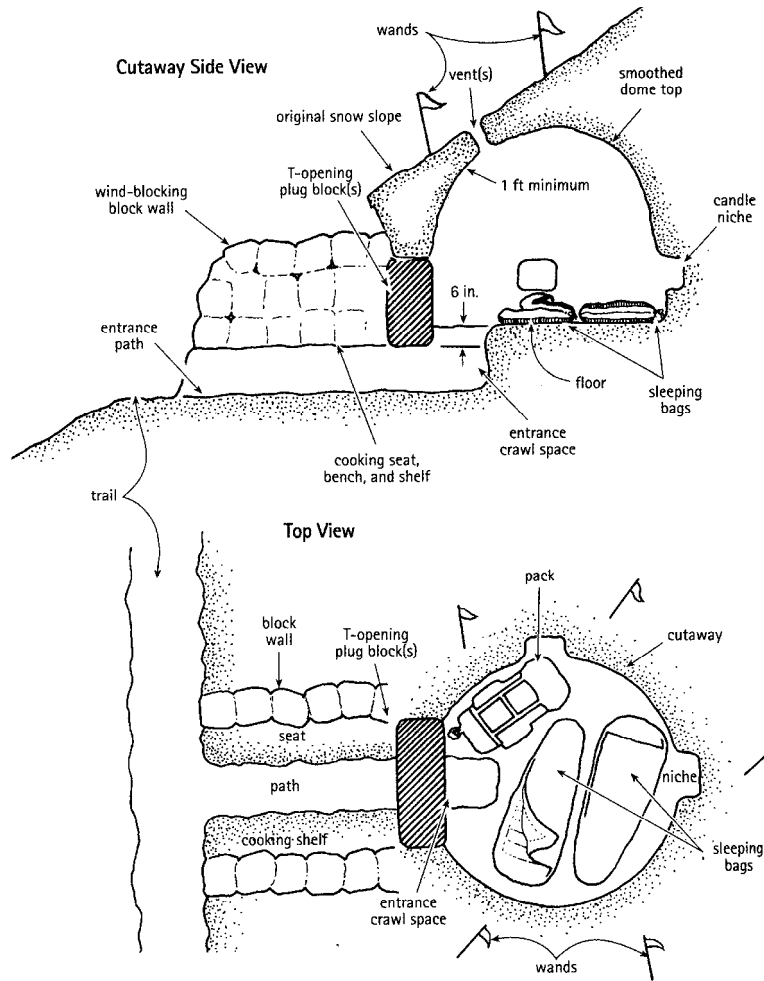

Publisher: The Mountaineers Author: D. Graydon, K. Hanson Title: 6th Edition – Mountaineering The Freedom of the Hills
 © This material has been copied under licence from CANCOPY. Resale or further copying of this material is strictly prohibited.

Figure 8.10 Snow Cave The T-opening is an enlarged opening for removing snow as you build the cave. The opening is closed with blocks at the completion of snow cave construction.

Signals

With a fire established and a shelter built, the immediate prospects for survival are greatly improved. The next step in the survival pattern is to make sure searchers will know you are there. Arrangements must be made so **signals** can be given and given **quickly** when the opportunity arises.

As most search teams carry a **radio**, this method is most hopeful in the short term. However, batteries will eventually run down so great care must be exercised in conserving this limited resource. Transmission uses much more energy than receiving. The instructions for effective radio operation in the communications chapter must be followed closely. **Keeping batteries warm** will help maximize energy output.

Another common type of signal available to well-equipped searchers is a **pencil flare gun**. Simple varieties do not propel the flare very high so care should be taken to ensure it will **clear the highest trees** in the area. Flare visibility will depend on atmospheric conditions and the time of day. Flares are bound to be limited and should only be used when there seems to be a high probability of being sighted. SAR personnel having flares in their equipment packs should make sure they are familiar with how to use them.

When buying refills for your pencil flares buy the correct flares for the type of pencil flare gun that you have. Erma flares will not fit in True Temper pencil flare guns.

Other types of signal must be improvised. The common international distress signal is **three of a kind**, be it **three fires, three smokes, three shots, three whistle blasts** or three of any other type of signal.

Fires or smokes are most effective if placed in a **triangular pattern** at least 30 m apart. **Dark or black smoke** is most effective in **winter** and can be produced by burning **pitch or rubber**. **White smoke** is more effective in summer and can be obtained by burning **green vegetation**. In any case, **some smoke is better than no smoke**. It should be remembered that the campfire itself is a signal and is more effective if it can be kept burning all night. A light in the shelter can make the shelter particularly visible at night.

Mirror Signaling

The device responsible for more aircraft spottings than any other type of signal is a **mirror**. The sighting mirror on a declination adjustable type compass can be used for this purpose. The aim is to reflect the sun onto the aircraft. Figure 8-10 illustrates one technique for using a signal mirror.

The thumb of your right hand is held in line with the plane and your right eye.

The mirror is held with your left hand in front of your left eye so that your right eye can see the plane and the thumb of your right hand.

The mirror is adjusted so light reflected off mirror hits the thumbnail of your right hand.

Inevitable shaking of mirror will cause some reflected light to hit aircraft.

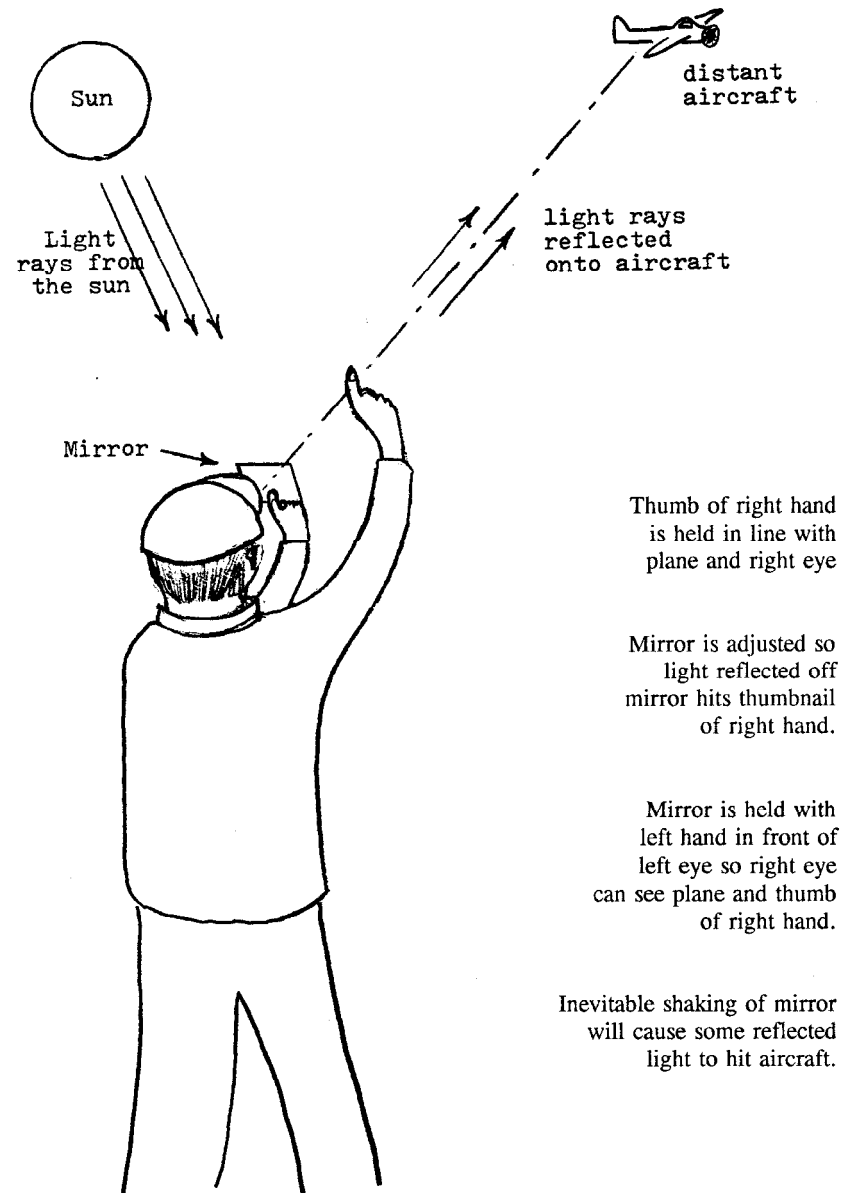

Figure 8.11 Signalling Aircraft with a Mirror

Ground to Air signals can be constructed in an open area using whatever materials are available. These signals, given in Table 8-11 should be as large as possible (7-10 m high) and offer the **maximum contrast** with the background. The lines should run in a NE-SW or NW-SE direction to catch the **maximum sun shadow**. Carrying **code cards** is strongly recommended but the main symbols to remember are the **V** and the **X**.

TYPE	SYMBOL	CODE
ICAO	V X N Y	Require Assistance Require Medical Assistance No or Negative Yes or Affirmative
Canada Only	↑ L L (space 10 feet apart) F L W	Proceeding in this Direction All is Well Require Food and Water Require Fuel and Oil Require Repairs

Table 8.1 Ground to Air Emergency Code

In summary, the **length of time** spent in a survival situation is often **governed** by the **effectiveness** of the survivalist's **signals**. Signals should be prepared **as soon as possible** and the effectiveness of **smoke** as a signal cannot be over emphasized.

Food and Water

With injuries treated, a fire burning, a shelter constructed and signals set, the next concern for the survivalist is food and water, Of the two, the need for water is more immediate. It is worth remembering that under normal circumstances, a person can survive only:

- 3 minutes without air
- 3 days without water
- 3 weeks without food

Water Requirements and Sources

Hydration is extremely important in SAR both during a survival situation and during a SAR task. Fortunately, water is readily available in most parts of BC, although some travel may be required to reach it and treatment of the water is required in most cases. The minimum daily requirement of water is about half a litre but physical characteristics, diet and the degree of physical activity may increase this figure. So too will environmental circumstances such as temperature.

Therefore, if the SAR task has a moderate level of physical activity one litre may be the **minimum** required while on a strenuous task 2 litres may be the **minimum** required.

Under hot conditions, cold conditions or at higher altitudes the amount of water required increases greatly and 4 litres per day could be required.

Methods of Disinfection

Water sources in the wilderness include **lakes, flowing water** and **snow**. Water used to be quite safe to drink from streams and lakes in BC but that is no longer the case. Microscopic organisms such as ***Giardia*** (beaver fever), ***Cryptosporidia***, ***Campylobacter***, ***amoebic dysentery*** and **Hepatitis A** have spread to many watersheds through contamination with human and animal wastes. In general, surface water and shallow wells should be considered contaminated and water should be disinfected before use. The main methods of disinfection are heat, halogens (iodine and chlorine) and filtration.

Snow is still a good source of pure water as long as it is taken from within the snow pack, away from trails or areas of animal activity. When using snow as a source of water it is important to add it to water a little at a time. Keep the water bottle inside your jacket. When melting snow for water it is more efficient to retain some water in the pot so that when the snow is added it forms a wet slush.

Boiling

Boiling is the best way to kill bacteria, viruses and parasites. A full boil for at least two minutes is recommended. At elevations over 2,000 meters (6,500 feet) you should boil water for at least three minutes to disinfect it.

Iodine

Iodine is effective against viruses and bacteria, can kill *Giardia* with a soak period but is not effective against *Cryptosporidium*. The soak time to kill *Giardia* depends on concentration and water temperature. Whenever possible use warm water (20°C) and let stand a minimum of 30 minutes after mixing. To be absolutely sure that *Giardia* has been killed in colder water an 8 hour soak should be allowed. If you are using 2% tincture of iodine, use 10 drops (0.5 ml) for every one litre of water. For iodine tablets, follow the manufacturer's directions.

Iodine has a few other problems such as it dissolves slowly in cold water, leaves a disagreeable taste and should not be used over a long period of time as it can cause thyroid problems. Even though ***Cryptosporidium*** has not been found in high numbers in pristine surface water iodine should not be relied on as your sole method of purification as it is not effective against ***Cryptosporidium***. It should also be remembered that halogens such as iodine have a brief shelf life.

Chlorine

Household bleach (5% chlorine) does not work well in killing off ***Giardia*** or ***Cryptosporidium*** parasites. The amount of bleach needed to kill these parasites makes the water impossible to drink.

Water Purification Recommendations

Water Filters

The effectiveness of water filters is dependent on the pore size. A filter should remove particles down to 0.4 microns to be effective. Most backcountry filters are effective against larger organisms such as *Giardia* or *Cryptosporidium*, some are effective against bacteria (such as *Campylobacter*) and none are effective against viruses. The use of iodine treatment to control viruses before or after filtration can make the purification more complete. Some filters come with a charcoal filter to remove the iodine while others have a built in iodine matrix.

Boiling water is the best way to kill bacteria, viruses and parasites. Therefore it is very important to carry a pot and lid and have some means to heat the water to a boil (light a fire, carry a stove).

It is important not to transport untreated water in your water bottle as the microscopic organisms can remain in the few drops left behind when you pour the water into your pot. Transport untreated water in your pot to assure that the pot and water will be sterilized when boiled

A combination of iodine and filtration is also effective against bacteria, viruses and parasites. Iodine is effective if *Cryptosporidium* is not a problem and if the water temperature is not too cold. Chlorine does not work well in killing *Giardia* or *Cryptosporidium*.

Sources of Water in Arid Regions

Dew

Heavy dew occurs in areas where there is warm days and cool nights. Dew on plants can be sponged off with a clean cloth and the cloth wrung out to obtain the moisture. Walking through bushes with cloths tied to your ankles can speed up the collection time.

Solar Still

This is effective in desert areas with cool nights and warm days. Dig a hole that is 90 cm across and 45 cm deep. Line the hole with green vegetation and put a collection can in the middle. Suspend a piece of plastic across the hole forming a cone. Put a stone on top of the plastic to orient the bottom of the cone over the collection can. As the day warms up water will condense on the under surface of the plastic and run down to drop off into the collecting can. The heaviest condensation will be at night when the plastic cools down. You can expect to get ½ a litre from this setup depending on the moisture content of the soil.

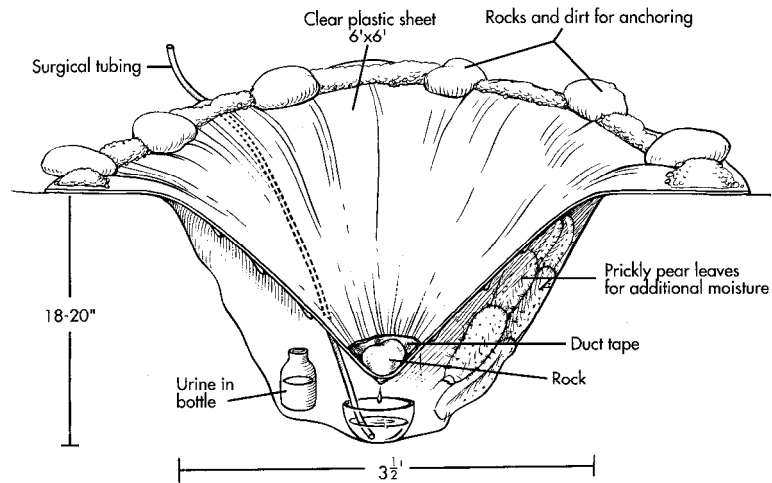

Publisher: Mosby Author: P.S. Auerback Title: Wilderness Medicine – 3rd Edition

© This material has been copied under licence from CANCEOPY. Resale or further copying of this material is strictly prohibited.

Figure 8.12 Solar Still

Other factors to consider about water:

The bluish-white water characteristic of a glacier-fed stream should be allowed to settle before consumption. The colour results from fine particles of grit in the water which, if swallowed, can cause intestinal problems. In the winter, **snow and ice** form suitable sources, but these materials **should be melted** over a fire rather than consumed directly, thereby wasting valuable body heat.

Some vegetation such as fruits and berries also serve as water sources. Ponds, puddles and other small bodies of still water may be used but considerable care must be exercised. It is important to remember that water is vital for the digestion of most foods and **one should not eat if one has no water**.

Do not eat snow to obtain water as this increases your risk of hypothermia.

Food

Assuming water is available, food concerns may be addressed. For adults the normal daily intake is about 2500-3000 calories, but life may be sustained indefinitely on just 500 calories a day. Again, minimum requirements depend on the physical characteristics of the individual, the level of physical activity and the environment. If the nutritional input is low, so too will be the physical output.

For the person who has some rations, a few basic principles should be followed:

- Do not eat on the first day.
- Physical activities requiring greatest exertion should be done on the first day.
- An inventory of all food sources should be taken.
- Perishable items should be eaten first.
- Small amounts should be eaten often rather than taking one large meal.
- If water is in short supply, carbohydrates are most suitable, requiring little water for digestion.

Generally, when food supplies are limited, so too must physical activity. Survival demands passive behaviour.

Finding food in natural surroundings presents some challenges. There are many edible items but recognition and procurement usually requires many years of experience. Foraging can expend more energy than the food value gained from the food that is gathered and stomach-upsets caused by inappropriate food can also cause a loss of energy. **In fact, no food may be better than a little food in the short term.** Using known quantities that are close by is the best principle.

Animals

When more substantial quantities of food are required, small game such as squirrels and rabbits give the best return for the energy expended in capture. A squirrel snare is the most efficient capture technique as it works 24 hours a day with minimal physical output. Boiling is generally the best method of preparation as it conserves food value and renders parasites harmless. When skinning rabbits or squirrels wear your first aid gloves to prevent transmission of Tularemia.

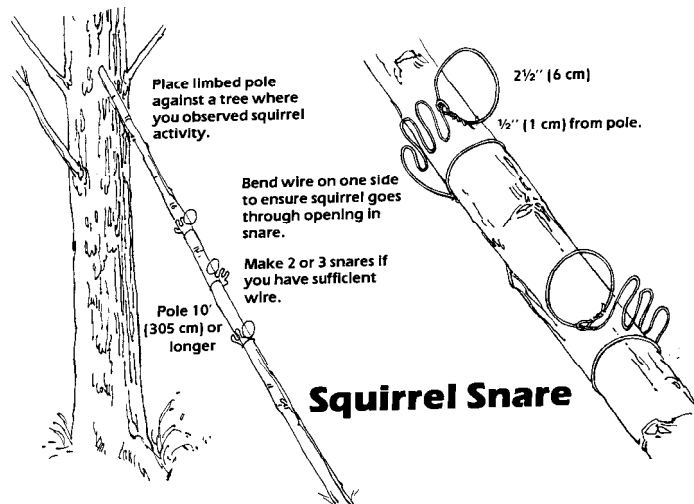

Publisher: Crown Publications Inc. Author: Province of BC, D. L. Hawley Title: Outdoor Survival & Safety

© This material has been copied under licence from CANCOPY. Resale or further copying of this material is strictly prohibited.

Figure 8.13 Squirrel Snare

Plants

Most green plants, leaves, blossoms, inner bark, roots, lichens, mosses and berries are edible at some time during their growing season. Some can be eaten raw but some must be cooked. Among the precautions to be exercised are:

- **Caution – Water hemlock is fatal if ingested.** Be extremely careful collecting around shallow streams. Water hemlock is 0.6-1.3m (2-4ft) tall has purple-streaked stems, hollow-chambered rootstocks, 2-3 lobed leaves and small white flowers. Ingesting extremely small amounts will kill you.
- Avoid mushrooms unless edibility is known with certainty.
- Avoid plants with milky sap unless positively identified as edible.
- Avoid white berries and berries growing in terminal clusters (clusters at end of branch).
- Avoid plants which when tasted in small amounts leave a burning or bitter taste in the mouth.
- In doubtful cases use an edibility test. Boil the plant and taste test a small amount. Then wait eight hours watching for possible ill effects.

It is impossible in this brief overview to deal adequately with the topic of edible plants and other matters related to the procurement of food. Books on survival deal with this subject in detail.

Sanitation (How to Shit in the Woods)

While out on an extended SAR mission the time will undoubtedly come when nature calls. It is extremely important for SAR volunteers in the wilderness to deal correctly with human waste disposal. Incorrect disposal of human waste has led to water source contamination, vegetation destruction, and the unsightliness of toilet paper and deposits in wilderness areas.

The general rules for waste disposal in the wilderness is to be at least 60 m away from any water source, trail or campground. When urinating, it is best to pick an area of rocks or bare soil and try to avoid hitting foliage as animals will damage the foliage to get the salt in the urine.

At lower elevations where there is an organic layer a “cat hole” can be dug into the organic layer (not into the subsoil) and the solid waste deposited in this hole. Toilet paper deposited in the hole takes a long time to breakdown so many people are now carrying it out. The cat hole should be covered and the forest floor returned to its original condition.

Travel

In alpine areas it is not recommended to bury solid waste as it will not break down. In heavily used areas and alpine areas the preferred minimal impact method of dealing with solid waste is to pack it out. The "blue-bag" system has been developed to deal with packing waste out. In this system there is an inner blue bag which is used to collect the waste and then the inner bag is put inside the outer bag. The waste is then carried out and the contents are dumped in an outhouse or toilet and the bag is disposed of in the garbage as for disposable diapers.

The general rule when lost is to stay put. This rule does not preclude travelling short distances for the purpose of finding firewood, constructing a shelter, making signals or finding water and food, but normally travelling longer distances should only be attempted in exceptional circumstances.

Even when travelling short distances for any of the reasons just mentioned, the trail should be marked to ensure an easy return to camp. Blazing trees with an axe, or marking the trail with snow blocks or piles of rocks are commonly used for this purpose. Flagging tape is ideal. Whatever type of marking is used, the marks must be readily visible in either travel direction.

In addition, a message should be left at camp describing where you have gone, when you left and when you expect to return. Searchers finding your camp during your absence will then know what to do.

In rare circumstances where survival prospects would definitely improve by lengthier travel, five basic requirements must be met:

- You must know where you are and where you wish to go.
- You must have a means of setting and maintaining direction.
- You must have the physical stamina for the task.
- You must have suitable clothing.
- You must have food, water, fuel and shelter available as well as the means to make signals.

If you lack any of the 5 requirements, travel should not be attempted. Once travel has been initiated, these requirements continue to apply. It is particularly important to conserve energy, stopping and resting if tired. Fatigue is the worst enemy of sound judgement. Looking after one's feet is also very important. Crossing large streams on logs and climbing or descending cliffs represent unacceptable risks and should be avoided if possible. So too is fighting one's way through dense vegetation. While travelling one must always be prepared to signal if an opportunity arises. The trail should be marked and messages left at regular intervals.

TRAVEL CONSIDERATIONS

Creek Crossings

See Chapter 18 - Shoreline Searches and Safety

Ice Crossings

While travelling through the wilderness in winter it may be necessary to cross a frozen body of water. Crossing frozen water is always risky and should only be done as a last resort. Factors to consider in deciding whether to cross a section of ice are the type of ice (how did it form), ice quality, ice thickness, and what is under the ice.

There are many different types of ice such as clear ice, snow ice, layer ice, candle-ice or old rotten ice. Guidelines for the strongest ice (clear, solid new ice) are as follows:

10 cm	walking/ice fishing
13 cm	snowmobiles
20 – 30 cm	vehicles

For ice other than clear solid new ice the thickness has to be increased and some types of ice should never be ventured out onto.

Ice is weakened if the water underneath it is moving and the faster the current the weaker is the ice. **Crossing ice that has moving water under it should not be done.**

Any object that protrudes through the ice absorbs heat and weakens the ice around it. Slush is a danger sign as this indicates that the ice is weakening. Ice covered by snow can either be stronger or weaker depending on whether the snow insulates the ice from melting or insulates it from freezing.

If it is decided that crossing is safe then using a stick to probe the ice ahead and walking in a shuffling motion is the best way to move across. Your pack waist strap should be undone for quick removal if you fall through. Ice picks (sharp items such as knives, ice axes, or pens) should be available and ready to be used to drag yourself out of the water. The use of a safety line may be beneficial. If you break through the safety line can be used to pull yourself out.

Breaking through the Ice

If you break through the ice you will not have much time before you become incapacitated. There are several things you should do:

- Breathe deeply and avoid the natural tendency to hold your breath. Tests have shown that this greatly improves your chances of surviving immersion hypothermia.
- How deep is it, maybe you can stand up.
- Remove pack, snowshoes, and skis.

- Break thin ice towards thicker ice but do not try to break ice all the way to the shore.
- Use skis or snowshoes on the edge of the ice to spread your weight and try to lift your self out.
- If you do not have something to spread your weight then extend your arms forward over ice, use any type of ice pick you can (walking stick, knife, keys, or pens) to get a better hold on the ice and draw yourself out on to your stomach.
- If you do not have a sharp item then extend your arms forward over the ice, kick with your legs and draw your hands back towards your waist pulling your body up on the ice on to your stomach.
- Stay on your stomach until stronger ice is reached.
- Roll well away from the weak ice before standing up.

Once out of the water it is extremely important to protect yourself from hypothermia. Get out of wet clothes and into dry clothes as quickly as possible. Build a fire and warm your neck, face and front of trunk first and construct a shelter if the weather is bad.

If a companion breaks through the ice use a pole or rope to pull him out. A loop in the rope can go around his body as he will probably be too weak to hold on to the rope. Do not go to assist the companion unless you have been trained in flat-ice rescue and have the equipment available.

Bear and Cougar Awareness

BC is fortunate to still have a large population of wildlife such as bears and cougar. While travelling through the wilderness of BC it is important to know how to avoid encounters with these animals and know what to do in a confrontation with them.

Bears

The two most common species of bears in BC are black bears and grizzly bears. Grizzly bears generally can be identified by the hump on their shoulders, massive heads, upturned snout and long claws. Both types of bears are extremely strong, can run as fast as a horse for short periods and are able to swim. Most bears can climb trees but adult grizzly bears tend not to.

Both types of bears are omnivores and tend to eat mostly vegetation but also eat fish, small mammals and occasionally larger mammals. Some tips to remember when travelling or working in bear country:

- Make noise while you work or travel.
- Keep the wind at your back as you move.
- Stay alert and be aware of your surroundings,
- Avoid areas that show signs of bear use.
- Leave potential feeding areas.
- Never camp near where bears feed.
- Do not keep food in your shelter, at night hang food from a tree branch at least 6 metres off the ground.
- Do not cook or eat near your shelter.

If you do encounter a bear:

- Try not to overreact, think about your circumstances.
- Leave the area if the bear has not become aware of you.
- If you can't leave, make the bear aware of your presence by talking and waving your arms.
- Move slowly away and don't run unless you are absolutely sure you can reach safety.

If you are carrying bear spray:

- It should be oil based not water based.
- Have it out of the package so you are ready to use it.
- Do not use it as a repellent. Spraying your campsite will not keep bears away and as the smell wears off bears are attracted to it.
- Use it as a last resort when the bear is very close.
- Make sure you are not spraying into the wind or you will receive the spray in your face.
- Bear spray may not be effective against an enraged or aggressive bear and its effectiveness on black bears is being questioned.

If a bear acts aggressively:

- Try to determine its intent ...defensive or predatory
- If you notice cubs or food nearby, or you startled the bear, it is probably acting defensively. Back away slowly and wave your arms. If a **grizzly bear** attacks, roll into a ball on the ground protecting your face and stomach. If it is a **black bear**, you should try to fight it. Attack its nose and eyes. Carry a straight knife in bear country rather than a locking knife as the straight knife can be grabbed with one hand.

Here are some things to do if a bear (black bear or small grizzly) seems to be stalking you:

- Try to intimidate it by acting aggressively – jump up and down and shout; and, try to climb a tree, if you have time.
- Remember – don't threaten, don't panic and don't run.

Your best course of action is to avoid bear encounters altogether. By following the key points above, you significantly reduce your risk of an accidental encounter.

Cougar

Cougar attacks are extremely rare but when they occur they receive a great deal of attention in the press. Most cougar attacks are against children but occasionally adults have been attacked. If you meet a cougar:

- Do not run (slowly back away)
- Stay calm
- Face the cougar
- Enlarge your image by picking up branches
- Give the cougar an avenue of escape

If a cougar acts aggressively to you:

- Arm yourself with a large stick, throw rocks and speak loudly and firmly
- If a cougar attacks **fight back!**

Insects

Insects such as mosquitoes, horse flies, “no-see-ums” can be a major problem for SAR personnel in spring, summer, and fall

The methods to protect yourself from insects are:

- Clothing – heavy clothing that is tight at the wrists and ankles and includes gloves and a head net can be effective in cool weather.
- Netting – head nets, and in hot weather shirts and pants made of netting which will be more comfortable than heavy clothing.
- Insect Repellents
 - DEET is effective against mosquitoes but not as effective against biting flies.
 - Etyhyl-hexanediol and dimethyl phthalate are more effective against biting flies but not mosquitoes.
 - Citronella and Avon Skin-So-Soft are less toxic repellents but check to see if they work for you.
- Try to avoid the use of perfumes and deodorant soaps as insects are attracted to some of them.

If you are allergic to bee or wasp stings let your GSTL and/or your SAR Manager know and carry the appropriate first aid supplies.

Ticks

Ticks are tiny bugs, about the size of a sesame seed, which feed on blood. Adult ticks can be distinguished from insects by having eight legs rather than six. They cannot jump or fly and do not drop from trees. They wait for hosts on the top of grasses and shrubs and attach themselves to the host as it brushes by. While most tick bites do not result in disease some do. Ticks have been found in BC carrying the organisms that cause numerous diseases such as Lyme disease, Rocky Mountain Spotted Fever, Tularemia and Relapsing Fever. While the chances of getting these diseases are small, it is worth taking steps to avoid being bitten.

Avoiding ticks

To protect yourself against tick bites:

- Walk on cleared trails wherever possible when walking in tall grass or woods.
- Wear light coloured clothing. Tuck your top into your pants and tuck your pants into your boots or socks and consider wearing gaiters.
- Put insect repellent (containing DEET) onto clothing and all uncovered skin.
- Check clothing and scalp (covered or not) when leaving an area where ticks may live. Make sure lighting is good so that you will not miss seeing the ticks.
- Regularly check household pets which go into tall grass and wooded areas.

Tick Removal

Prompt removal of the tick is important as the longer the tick remains on a person's body, the greater the chance of disease transmission.

Traditional removal methods such as tweezers (with or without twisting), fingers, petroleum jelly, fingernail polish, applying kerosene or use of a hot match head are **not recommended** as any one of these procedures can cause the tick to vomit, defecate or urinate. This can increase the likelihood of infection as the infectious agents are within the tick's bodily fluids.

Dr. E.K. Murakami (Clinical Associate Professor, Department of Family Practice, UBC) and Dr. S. Christie have developed a new field technique for removal of ticks. This new technique avoids any vomiting of the intestinal contents of the tick.

The equipment required for this technique is a piece of drinking straw and a piece of thread.

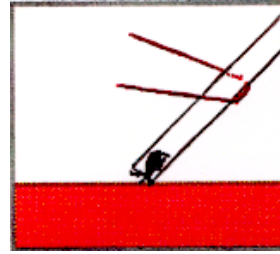

Figure 18.14 Step 1 The straw is placed over the wood-tick and is held at a 45°. A piece of thread is placed around the straw and slid down to the skin.

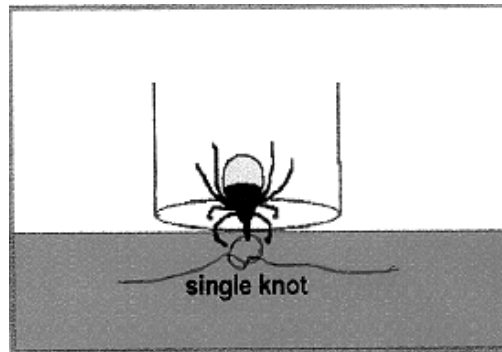

Figure 18.15 Step 2 The thread is brought down against the skin around the tick's jaw. A single knot is made and slowly tightened to close around the jaw of the tick.



Figure 18.16 Step 3 Remove the straw and pull gently upwards on the string. It may take up to a couple minutes for the tick to release. This method avoids regurgitation of infectious agents and the tick remains alive and in one piece.

After the tick has been removed, place it in a container with a piece of damp gauze. Label container with date shipped, name of person bitten, what part of body bitten, what part of the province the tick came from.

This container should be taken to your local health unit as soon as possible for testing at the provincial laboratory.

Once the tick has been removed, clean the bite area with soap and water or rubbing alcohol. Wash hands with soap and water.

If you have the following symptoms within days or weeks after being bitten by a tick please report them to your physician immediately:

- General symptoms of headache, muscle and joint pains, fatigue or weakness of the muscles of the face.
- Skin rash, especially one that looks like a “Bull’s Eye”. It may or may not be where the bite was.

Rabies

Rabies is a viral disease that is transmitted through saliva, typically by an animal bite. This disease affects the nervous system and can kill its’ victim if not treated in time. It can be carried by wild animals, domestic pets and farm animals so special care should be taken to avoid any animal which appears to be dead or ill. In BC, by far the most common rabies carrier is the bat. If you are bitten or scratched by a bat, or any animal that is acting strangely there are two things you should do:

- The first thing to do with any animal bite is to wash the wound well with soap and water. This lessens the chance of any infection.
- Seek medical attention right away.

Hantavirus Pulmonary Syndrome

Hantavirus pulmonary syndrome (HPS) is a severe (fatal) respiratory illness that is spread to humans when airborne particles of deer mice excreta or saliva are inhaled or when there is direct contact with the excreta. Other types of rodents (pack rats) may also be carriers of this disease. There have been a number of fatal cases of HPS in BC and SAR volunteers should take measures to avoid coming in contact with rodents or their habitat. Ways to avoid coming in contact with rodents:

- Do not touch dead rodents without disinfecting and using gloves.
- Do not use cabins that are rodent infested.
- Do not camp near rodent faeces, burrows or dens.
- Do not sleep on the bare ground use a tent with a floor.
- Eliminate rodents and use rodent proof containers to store food.

Rattlesnakes

Rattlesnakes are not found throughout BC but are found in the Okanogan Valley. Rattlesnakes have triangular heads, pits between their eyes and nostrils and rattles at the end of their tails. Most are 1.2 m long and brown, red or gray in colour. Venom is injected into the victim in 70-80% of the bites with rapid swelling, bruising and pain at the bite site being a good indication that venom has been injected. Although rattlesnake bites are rare in BC while travelling through the bush in the Okanogan one has to take some precautions.

Rattlesnake Precautions

- Wear stout boots and watch where you put your feet.
- Use a stick to check out holes, logs or to turn over stones before placing feet or hands nearby.
- Step on top of obstacles such as logs or rocks not over them.
- Before sitting down for a rest, check logs, stumps, rocks and the surrounding area.
- If you encounter a snake stay calm and back off giving it lots of room.
- Check clothes and packs before putting them on. Check bedding before getting in.
- A healthy adult that is bitten by a rattlesnake may get seriously ill but has a good chance of survival.

If bitten:

- Try to identify the snake.
- Clean wound.
- Apply sterile dressing
- Do not use pressure bandages, tourniquets, electric shock, ice or incisions on the bite.
- Do not use oral suction but mechanical suction devices can remove some of the venom if used within minutes of the bite.
- Keep limb below level of the heart.
- Remove any constrictive items such as rings
- Keep patient from moving any more than necessary.
- Keep patient hydrated.
- Transport patient to nearest hospital facility.

Lightning

While travelling through the wilderness and especially at higher elevations there is a chance of being caught in a thunderstorm with the accompanying lightning. Every year lightning kills approximately 300 people (30% of those hit) either from direct hits or from the lightning current jumping from hit objects onto the victim. If you are caught out in the open during a thunderstorm seek cover.

- Avoid standing in the middle of meadows or under solitary trees, go to low ground in an open valley and crouch with hands off the ground amid shorter trees.
- If there is only solitary trees in a meadow couch down twice as far away from the trees as they are tall.
- Get off hilltops, mountain peaks or pinnacles.
- Do not go into shallow caves or stay at the mouth of deep caves as the electrical charge can jump across the cave mouth.
- Get rid of metal and graphite equipment and insulate yourself from the ground with a pack or foam pad.
- Crouch or sit down on your insulating material facing downhill with your hands not touching the ground.
- Do not lie flat on the ground.
- If in a group during a thunderstorm do not huddle together but spread out. This prevents everyone getting injured if there is a lightning strike.

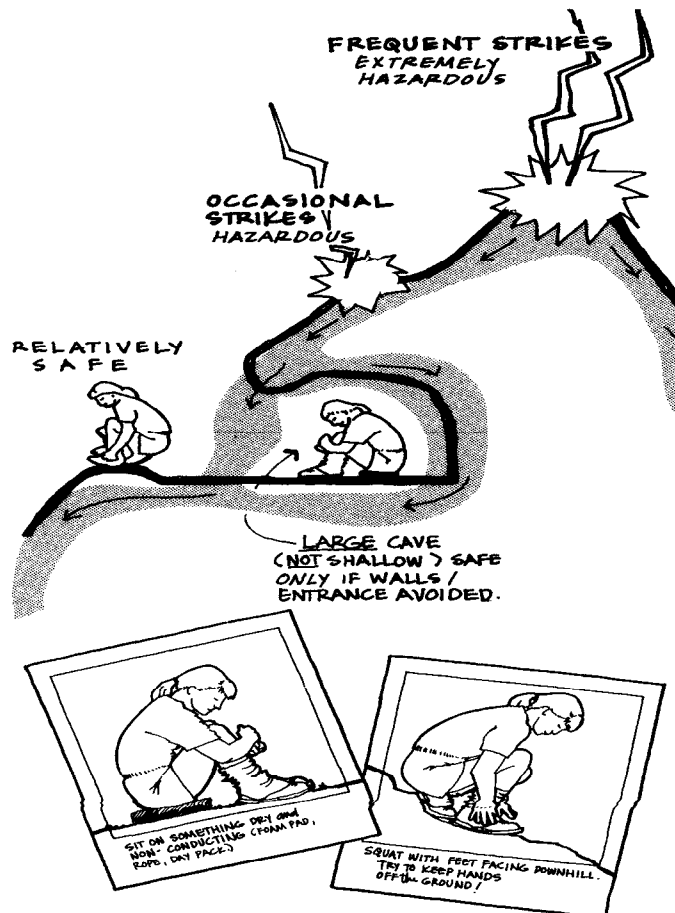

Publisher: NOLS Publications Author: T. Schimelpfenig, L. Lindsey Title: Wilderness First Aid

© This material has been copied under licence from CANCOPY. Resale or further copying of this material is strictly prohibited.

Figure 8.17 Preferred Body Position During Lightning

**Additional
Resources**

Auerbach, Paul S. *Wilderness Medicine*. St. Louis, MO: Mosby – Year Book Inc., 1995.

Bowman, W.D., *Outdoor Emergency Care*. Second Edition. National Ski Patrol System, Inc, 1993.

Cooper, Donald C., LaValla, Patrick “Rick” and Stoffel, Robert “Skip”. *Search and Rescue Fundamentals, 3^d Edition*. Olympia, WA: Emergency Response Institute, 1996.

Fear, Gene. *Surviving the Unexpected Wilderness Emergency*. Tacoma, WA: Survival Education Association, 1979.

Graydon, Don, and Hanson, Kurt. *6th Edition, Mountaineering, The Freedom of the Hills*. Seattle, WA: The Mountaineers, 1997.

Province of British Columbia, Ministry of Forests. *Bear Aware Student Manual*.

Simer, Peter, and Sullivan, John. *The National Outdoor Leadership's Wilderness Guide*. New York, NY: Simon & Schuster, Inc, 1983.

Wiseman, John “Lofty”. *The SAS Survival Handbook*. Hammersmith, London: HarperCollins Publishers, 1996.

Further references listed in the Bibliography.

Chapter Review

Please answer the following questions on a separate sheet of paper so that another student can use this manual. The answers to these questions are located at the end of the manual.

1. What is meant by "STOP"?
2. What is the most important factor in a survival situation?
3. You are an air spotter and you spot a large V on the ground. What does it mean?
4. If a black bear attacks you, what should you do?
5. What is the survival pattern?
6. What is one problem with a lean-to shelter?
7. Why is it important to consider your Energy Budget?

Answer **True** or **False** to the following statements.

8. A person is hypothermic once shivering stops.
9. A snow trench takes less effort to build than a snow cave.
10. Iodine is the most effective water disinfection method.
11. Oral suction is the best way to treat rattlesnake bites.
12. Gathering food in a survival situation is always a useful task.

Chapter 9 - Communications

Upon completion of this chapter, you will be able to:

- Describe common radio equipment used in SAR.
- Operate a portable radio and maximize the effectiveness in terms of sensitivity, range and battery life.
- Describe how repeaters are used in SAR communications.
- Demonstrate the use of equipment inventory sheets for communication equipment.
- Explain why all communications during a search should be directed through the command post serving the SAR Manager.
- Demonstrate the maintenance of a communication log.
- Express time using the 24 hour clock system.
- Use the phonetic alphabet.
- Recite the vocabulary in common use in radio communications associated with SAR.
- Use appropriate calling procedures when operating a radio.
- Discuss the appropriate use of codes in SAR operations.
- Perform a radio check.
- Understand how scanners may effect radio communication.
- Describe the main procedures used in emergency communications.
- Describe how amateur ham radio operators can be used in SAR.

Introduction

Time and time again communication is identified in SAR task reviews as one of the weak links in an operation. Teams out in the field cannot be contacted, batteries go dead, information is not clearly worded, or there is too much unnecessary chatter. It is therefore very important for volunteers to be familiar with communication operations to prevent some of these problems.

Under the former communication regulations it was a requirement for persons operating a land station involving public safety to obtain a Radiotelephone Operator's Restricted Certificate (Land) (RORC). Therefore, PEP required SAR members to get their RORC (Land) as part of being Basic SAR certified.

The new radio communications regulations make this unnecessary and the communication information that Ground SAR personnel are expected to know is now found in this chapter.

Like many skills in SAR, practice is essential to become proficient in radio operation.

Radio Equipment

The aim of this section is to provide non-technical information on radio communications equipment that may be used by people associated with PEP. The terms listed are in common use and should be understood by all GSAR members.

Equipment Types

Three types of equipment are likely to be encountered by PEP volunteers.

Base stations that are at fixed locations.

Mobile transceivers that are usually fitted into vehicles.

Portable transceivers that are usually the hand-held type.

Equipment Components

A two-way radio consists of two parts, one of that emits a signal and another that receives it. In most sets, parts of the circuitry are used for both transmission and reception and the two together are known as a "transceiver."

Frequencies

A transmitter emits electromagnetic energy on one specific frequency at any one time. The lowest such frequency is 14,000 cycles per second, also expressed as 14 kilocycles per second or more commonly as 14 kilohertz (kHz). The highest frequency used is about 3,000,000,000 cycles per second, or 3,000 megahertz (MHz) or more commonly called 3 gigahertz (3Ghz). The band from 136 MHz to 174 MHz is known as very high frequency (VHF) and is the band most commonly used by PEP.

Frequency Bands

Very Low Frequency (VLF)	0	to	30 KHz
Low Frequency (LF)	30	to	300 KHz
Medium Frequency (MF)	300	to	3,000 KHz
High Frequency (HF)	3	to	30 MHz
Very High Frequency (VHF)	30	to	300 MHz
Ultra High Frequency (UHF)	300	to	3 GHz (3,000 MHz)

Frequency Allocation

The management of radio frequency allocation of PEP radios rests with the PEP Head Quarters (HQ) Communications Officer. All licence inquiries, and authorization for use, must be directed to the Communications Officer through the appropriate Regional Manager. Listed are the frequencies licenced and utilized by PEP.

Frequencies Licenced and Utilized by PEP

- 149.495 MHz VHF-FM
- 148.655*
- 148.685*
- 149.525

*Restricted, only to be used in areas that are approved by the PEP HQ Communication Officer

Noise Interference

Radio waves from of all frequencies are constantly being emitted from both natural and man-made sources and are detected by any receivers. These unwanted signals are referred to as noise. F.M. is more immune to noise than A.M. because noise is mostly an A.M. signal. Higher quality equipment of either type, with improved receiver specifications, is more immune to noise.

Power

Power output is rated in terms of watts and is the power output of the transmitter that is fed to the antenna system. Typical output from portable radios is 2 to 5 watts while Base or mobile radio output can be considerably higher. The antenna cable and the type of antenna will have a bearing on the effective radiated transmitter power and receiver performance.

Controls of Low Power Radios

The controls of radios used in PEP operations are very similar. Personnel should be familiar with the purpose and operation of the following controls and equipment.

On / Off Volume

The on/off switch and the volume control are usually connected to one knob. To turn the radio on, turn this knob clockwise. To increase the receive volume, turn this knob further clockwise.

Squelch

All radio receivers produce noise when there are no incoming transmissions. The squelch circuit mutes the radio speaker when there are no incoming transmissions on the channel. In some radios the squelch control is automatic and there is not a squelch control that needs to be adjusted. The squelch setting affects the receive sensitivity of the radio. To obtain the best sensitivity from the receiver the squelch control must be adjusted correctly. To set the control, turn the knob in one direction or the other until noise is heard. Then, turn the knob in the other direction until the noise just disappears. Note that in portable radios the squelch may open (noise is heard) due to the radio battery becoming depleted. The noise will generally be heard in intermittent bursts and a readjustment of the squelch control will cure the problem until the battery is replaced.

Frequency Switch

If the radio is equipped to operate on more than one frequency (channel) set the knob or switch to the frequency desired. This is usually indicated by F1, F2, F3, etc. Many SAR groups are now using programmable radios in which the radio frequencies can be imputed through a keypad and then stored in memory.

When involved in mutual aid it is important to clarify before heading out on your assignment that “our channel 1” is the same as “their channel 1”.

Push to talk

This switch is used to activate the transmitter. When released, the transmitter is deactivated and the radio is back to receive mode.

Antenna

A portable radio will generally come with one of two types of antenna. The first type is the helical antenna. It is a short, flexible antenna covered with PVC plastic. The second type is the telescopic or collapsing antenna. It must be fully extended before transmitting. Although the helical antenna is shorter and less efficient than the telescopic antenna, it is superior in the bush where the telescopic antenna could be easily broken.

Communication Equipment Control

Maintaining control of radio equipment is a difficult but essential part of any operation. An equipment inventory sheet (ICS 303) is used to sign out radios and spare batteries to search teams. A copy of the equipment inventory sheet is shown at the end of this chapter. Every SAR group requires a few members to take specific responsibility for all matters associated with communications. These people will look after maintenance of radios, standardizing of the frequencies available on the team radios, battery charging and maintenance.

Power Supply for Low Power Radios

Power for low power radios usually consists of a self-contained battery. The operating life of a battery can be determined by the type of battery used and the duty cycle that is applied to the battery. All battery types operate best at around room temperature. Keeping the radio tucked inside one's clothing when operating it in cold weather will help to keep the battery warm and achieve its maximum operational life. Heating a battery or placing it near a source of heat should be avoided as the battery will deteriorate and become damaged. All batteries discharge slowly when they are not in use.

Fully charged nicad batteries when used for a short period of time without completely discharging and then put back in the charger will develop "memory". A dead battery indication will start to appear on a portable radio with a battery that has developed "memory" and the radio will go dead after a short use. To prevent memory from developing the battery must occasionally be allowed to completely discharge. This will prolong battery life. This discharge can take place on operations if a spare battery is kept on hand to replace the dead one, or the radio can be left with the squelch open until the battery is dead. However, this will only work on older models with external squelch control, and will not work on newer radios with internal squelch settings.

Another alternative is to take the batteries to a radio service shop and have them placed in a battery analyser to have the battery cycled. They will also be able to tell the condition of the battery. Non-rechargeable batteries should be used within 1 year of purchase. Nicad batteries that are sitting on the shelf should be recharged every 6 months.

Propagation of Radio Waves

The communication distance achieved with a radio will depend on the power of the transmitter, the sensitivity of the receiver, the frequency used and the path between the transmitter and the receiver. A transmission in the VHF band will generally travel in much the same way as light. It will almost follow the line of sight between transmitter and receiver and can be reflected off walls, mountainsides, buildings, etc. Thus, communications can be blocked by objects in the path. Communications can be restored by moving the transmitter to the left or to the right and up or down to restore the line of sight or the reflected path.

Specific Procedures for Ground SAR

Generally, the higher the transmitter, the better its range; from a mountaintop it could be 50 km. As it is not always possible for someone to take their transmitter to the top of a mountain to improve their range, other techniques must be found. One method is to place a person with a transceiver at a high intermediate point to act as a "relay." Another method used by SAR groups is a "repeater." A repeater is a permanent unmanned installation usually placed on a mountaintop that receives messages on one frequency and simultaneously re-transmits the messages on a second frequency.

Following proper voice procedures ensures that all participants in SAR operations will be able to communicate in a manner that is readily understood. In addition to these procedures, it is important to remember the following principles if smooth running communications are to be achieved.

- Communications should be conducted using the "**Directed Net.**" This policy means that the station that is serving the SAR Manager is Net Control (base radio or Incident Command Post [ICP]) and all communications are directed through that station. Any GSAR member may be called upon to be the Net Control radio operator.
- There must not be any "chit-chat" between search teams except with the permission of Net Control.
- Messages must be short and concise. Thinking before speaking is essential.
- The Net Control station serving the SAR Manager must keep a brief log of all communications. It is important that the radio log be kept as exact as possible as the log can be used in reviews or court proceedings. The log can also include information such as when other agencies arrived and when impromptu meetings were held. The ICS radio log form (ICS 309) is shown at the end of this chapter.

Radio Operating Procedure

Preparation: Turn on the radio and adjust the volume and squelch as described earlier. Set the radio on the appropriate channel and it is ready to receive incoming messages.

Transmitting: Monitor the channel to ensure that calls in progress will not be interrupted. Hold the microphone about 10 cm (4 inches) from the mouth. Plan what you are going to say before speaking using correct calling procedures that are covered later in this chapter. Remember there may be people with scanners picking up your transmission so discretion has to be used. Press the "push to talk" switch and in a normal voice, send the message. Release the "push to talk" switch to hear the reply.

If transmission and/or reception are poor, it may help to point the antenna in a new direction or move to a new higher spot or a spot more in the line of sight with the target receiver. It may also be that your battery is losing power and a freshly charged battery should be tried. At least one spare battery should be taken out in the field with every radio.

The efficient use of the radio depends on the method of speaking and on the articulation of the operator. Speak without whispering, mumbling or shouting. Words of similar length containing the same vowel sounds are apt to sound alike. Therefore the following procedures are to be followed.

Date and Time

The twenty-four hour clock system is to be used when expressing time. Time is to be expressed and transmitted by means of four figures, the first two numerals denoting the hour past midnight and the last two numerals denoting the minutes past the hour.

Examples:

12:00 midnight	is expressed as 2400 (up to midnight) or 0000 (first moment after midnight)
12:45 am	is expressed as 0045
1:30 am	is expressed as 0130
12:00 noon	is expressed as 1200
1:45 pm	is expressed as 1345
4:30 pm	is expressed as 1630
11:45 pm	is expressed as 2345

Some parts of BC straddle two time zones so in these areas the time zone being used should be clarified on any task.

Phonetic Alphabet

Another way to eliminate confusion in radio communications is to use the phonetic alphabet. The words and their pronunciation, (primary emphasis on the capitalized syllables) in the following spelling alphabet have been agreed on internationally. These should be used if communication is difficult or there is a chance of the receiving operator misspelling a word. It should not be used indiscriminately or time will be lost.

The phonetic alphabet

Letter	Word	Pronunciation
A	Alfa	AL fah
B	Bravo	BRAH VOH
C	Charlie	CHAR lee
D	Delta	DELL tah
E	Echo	ECK oh
F	Foxtrot	FOKS trot
G	Golf	GOLF
H	Hotel	Hoh TELL
I	India	IN dee ah
J	Juliet	JEW lee ETT
K	Kilo	KEY loh
L	Lima	LEE mah
M	Mike	MIKE
N	November	Nov VEM ber
O	Oscar	OSS cah
P	Papa	Pah PAH
Q	Quebec	Keh BECK
R	Romeo	ROW me oh
S	Sierra	See AIR rah
T	Tango	TANG go
U	Uniform	YOU nee form
V	Victor	VIK tah
W	Whiskey	WISS KEY
X	X-ray	ECKS ray
Y	Yankee	YANG key
Z	Zulu	ZOO loo

Transmission of Numbers

All numbers should be transmitted by pronouncing each digit separately.

Examples:

75 becomes	seven five
100 becomes	one zero zero
5800 becomes	five eight zero zero

Numbers containing a decimal point are transmitted as above with the decimal indicated by the word "decimal".

Example:

248.3 becomes	two four eight decimal three
---------------	------------------------------

Procedural Words and Phrases

Slang expressions such as "OK", "Over and Out", "Breaker Breaker", "Ten-Four" should not be used. The following is a list of a few words and phrases that should be used instead:

WORD OR PHRASE

MEANING

- | | |
|---------------|-----------------------------------|
| • Affirmative | Yes, or permission granted. |
| • Confirm | My version is... is that correct? |

- Correction An error has been made in this transmission (or message indicated). The version is...
- Go ahead Proceed with your message.
- How do you read? Self explanatory.
- Negative No, or that is not correct, I do not agree.
- Over My transmission is ended, expect a response.
- Out Conversation is ended, no response expected.
- Roger I have received all of your last transmission.
- Say again Repeat message, Do not say Repeat..
- Stand by Please wait.
- That is correct Self explanatory.
- Verify Check with the originator that the message is correct.

Call Signs

Distinctive call signs, consisting of a group of letters and or numbers, can be assigned to the base, mobile and portable radios. Call signs should be used for initial contact and again when communications have concluded. It is recommended that SAR groups use their team name in combination with numbers to identify members and equipment. This makes identification of volunteers and equipment much easier during mutual aid calls.

CALLING PROCEDURES

In the following examples the commonly used word “base” has been used however with the implementation of ICS the correct term is Incident Command Post or ICP.

Before transmitting, the operator should listen to ensure that no one else is transmitting, and thus interfere with the other transmitting station. The call sign of the station being called is ALWAYS spoken first, followed by the words “THIS IS” and your own station call sign.

Example: Base is calling Team One...

- “Team One THIS IS Base OVER”
- “Base THIS IS Team One go ahead OVER”

If the base wishes to communicate to more than one station, they are called out in any order and respond back to base in the order in which they were called.

Example: Base is calling Team Two, Five and Six...

- “Team Two Five and Six this is Base Over”
- “Base this is Team Two Over”
- “Base this is Team Five Over”
- “Base this is Team Six Over”

Base would then give the message without calling each station again. The teams would each acknowledge, in the order that they were called, the message that they received from base by saying:

“Base this is Team _____ Roger Over”

If an operator hears a call but is uncertain that the call is intended for his/her station, he/she should not reply until the call has been repeated and understood. If an operator hears a call that is understood to be for him/her however does not catch the call sign of the station calling they should request them to repeat it by saying:

“Station Calling this is (Call sign being called) Say Again Over”

Anyone transmitting a message should think about what they are going to say before getting on the air and stumbling for the right words, thus tying up the air waves. Excessive transmission also drains the batteries faster as most of the battery drain comes from transmitting.

Codes

Codes should be kept to a minimum and kept as simple as possible. This will make it less confusing and you will make fewer mistakes. It is recommended, however, that codes be used to describe the discovery of a deceased subject. The intent is to manage the situation as much as possible, out of respect for the family, without news of the discovery being picked up on a scanner. To keep it simple it is suggested that each SAR Group decide what phrase they will use to indicate that the subject was found deceased. Base can now ensure that there are no family members around and will proceed to get more information from you. Other teams hearing the transmission will standby until contacted by Base.

Other types of codes such as 10 codes should not be used by SAR teams.

SIGNAL OR RADIO CHECKS

If you are requested to give a radio check give a brief description of how well you are receiving the transmission.

Use phrases such as:

Strong and clear,
Weak but clear,
Broken up,
Unreadable

Example: Team Two is requesting a radio check from Base.

“Base, This Is Team Two For A Radio Check Over”

Example: The Base can understand but with some difficulty.

“Team Two This Is Base You are clear but weak Over”

Emergency Communications

Distress Signal

Ham radio operators use a more complex system called "RST" for reporting readability, strength and tone. Numerical values are given for each of the categories. As most SAR volunteers do not spend enough time using the radio to remember the system, the radio check protocol listed above will be used.

Distress, urgency and safety procedures are laid down by international regulations and are designated primarily for aeronautical and maritime services. Use of these types of communications in the land service is very rare but GSAR members should have an understanding of the main procedures.

The spoken word for distress is "MAYDAY"

The distress signal indicates that the station sending the signal is:

- 1) Threatened by grave and imminent danger and requires immediate assistance, or
- 2) aware that an aircraft, ship or other vehicle is threatened by grave and imminent danger and requires immediate assistance.

The distress call should comprise:

- 1) the distress signal "MAYDAY" spoken three times;
- 2) the words "THIS IS";
- 3) the call sign of the station in distress spoken three times.

The distress call has absolute priority over all transmissions.

The acknowledgement of receipt of a distress message shall be given in the following form:

- 1) the call sign of the station in distress spoken three times;
- 2) the words "THIS IS"
- 3) the call sign of the station acknowledging the receipt spoken three times;
- 4) the words "RECEIVED MAYDAY"

Actions by stations acknowledging receipt of a distress message:

- 1) Forward information immediately to the appropriate search and rescue agency or organization (Air SAR is the responsibility of the Canadian Armed Forces, Marine SAR is the responsibility of the Canadian Coast Guard).
- 2) Continue to guard the frequency on which the distress message was received.
- 3) Notify any station with direction-finding or radar facilities that may be of assistance, etc.
- 4) Cease all transmissions that may interfere with the distress traffic.

Urgency Signal

The urgency signal indicates that the station calling has a very urgent message to transmit concerning the safety of an aircraft, ship or other vehicle, or the safety of a person.

The urgency signal is "PAN PAN" spoken three times at the beginning of the first communication.

Safety Signal

The safety signal is used mainly in the maritime mobile service. It indicates that the station calling is about to transmit a message concerning the safety of navigation or giving important meteorological warnings.

The safety signal is the word "SECURITY" spoken three times at the beginning of the first communication.

Secrecy of Communications

Radio Operators and all persons who become acquainted with radio traffic are bound to preserve the secrecy of correspondence. This includes communications transmitted and received.

Radio Station Licences:

All radio stations must be licenced. The licence, or a copy of, must be posted in a conspicuous place near the radio equipment.

The licence generally specifies the call sign of the station, the frequencies to be used for transmitting and any special conditions under which the station should be operated.

Fines

Fines or imprisonment can be given to anyone who sends:

- Profane, obscene or indecent language.
- False distress signals.

Or establishes a radio station without a radio licence.

To obtain a radio licence an application along with the prescribed fee should be submitted to Industry Canada (DOC). The radio equipment must be type-approved or found to be technically acceptable for licensing by Industry Canada.

Amateur Ham Radio Operators

Amateur ham radio operators can be a useful resource for SAR groups. These people are knowledgeable about radios and can help operate and maintain base radios, portable radios and repeaters. This frees up SAR members for other tasks.

Additional Resources

Industry Canada. Study Guide for the Radiotelephone Operator's Restricted Certificate (Land) No longer produced.

Further references listed in the Bibliography.

Chapter Review

Please answer the following questions on a separate sheet of paper so that another student can use this manual. The answers to these questions are located at the end of the manual.

1. How do you respond to a request for a signal check?
2. What is the difference between a mobile and a portable radio?
3. Why is a "Directed Net" used in SAR?
4. What is Squelch?
5. Use the phonetic alphabet to spell "Gerry Johnsen".
6. Use the twenty-four hour clock to express the following times
9:45 pm, 3:47 am, 6:20 pm.

Answer **True** or **False** to the following statements:

7. "Roger" means that you have received all of the last transmission.
8. "Ten-four" is used to agree with the transmission.
9. Keeping communication logs is optional.
10. "3278" is pronounced three two seven eight.

Chapter 10 – Orientation to Rope Management

Upon completion of this chapter, you will be able to:

- Describe the circumstances where the use of ropes and knots is appropriate for GSAR.
- Compare and contrast the types of rope that are encountered in SAR and the relative advantages and disadvantages of each.
- Describe and demonstrate proper rope care, handling, and management.
- Define the following: dynamic rope, static rope, tubular webbing, flat webbing, accessory cord.
- Recognize and demonstrate tying the following knots: Figure Eight on a Bight, Figure Eight Follow Through, Figure Eight Follow Through Bend, Ring Bend (Water Knot, Tape Knot, Overhand Bend), and Italian Hitch (Munter Hitch).
- Define carabiners and describe their use.
- Describe proper handling of carabiners.
- Demonstrate a single point anchor.
- Demonstrate the use of a rope for a hand line.
- Demonstrate a belay for an assisted raise or lower using an Italian Hitch.
- Use the appropriate belay signals during an assisted raise or lower.

Introduction

The responsibilities of a GSAR member include the ability to perform basic rope management functions. This includes tying of rescue knots involved in a ground-based evacuation and, maintaining and managing a rope(s). This course qualifies the GSAR member to aid or assist in stretcher carries through uneven terrain under the supervision of a certified Ground Search Team Leader. It does not qualify the GSAR member to participate in technical rescues

The occasions for which ropes and knots are required in GSAR are limited. The most likely circumstances necessitating their use include:

- As a safety line for a stretcher carry on low angle slopes
- As a hand line on a slope
- As a tool in shelter construction

It is recognized that some groups utilize more advanced rope management techniques such as rappelling or embankment rescue techniques in ground search applications. Rappelling should not be done unless the GSAR member has received specialized instruction. Embankment or cliff rescue techniques should only be performed by individuals trained at the Rope Rescue Team Member or Team Leader levels, certified by the Justice Institute of BC

In GSAR, depending on the terrain, a rope may be used to assist in stretcher travel. If the angle of the slope and its surface is such that if the stretcher were to drop to the ground it would stop, then the use of a single rope with an Italian Hitch is acceptable. If conditions are such that if the stretcher was dropped it would slide or skitter down the slope then a rope rescue team utilizing a technical two rope rescue system would be required.

A rope may also be secured to anchors at the top of a hill, at the bottom of a hill and in several places on the hill to be used as a hand line. The hand line is used to assist travel up and down the hill. As you will not tie into this line it should only be used on slopes where if you slipped you would not slide down the slope.

Types of Ropes

Fibre ropes are made from either natural or synthetic fibres. The natural fibres come from various plants including hemp, manila and sisal. The synthetic ropes include nylon, polypropylene and the polyesters.

Natural Fibre Ropes

Natural fibre ropes should not be used in SAR work.

Synthetic Fibre Ropes

Of the three synthetic fibres mentioned, polypropylene is the lightest. Ropes from this synthetic material will float, and are not weakened by, nor do they absorb water. These properties make

polypropylene ropes an obvious choice for water activities like marine rescues.

Polyester (e.g. Dacron) dominated the rescue scene for a time. However, as the demand for low stretch rope increased, nylon ropes became commonly used. These ropes may have an elongation of as little as 1.6% at 90 kg and have a breaking strength of 3175 kg. (under ideal laboratory conditions). They are often called “kernmantle” rope (or Perlon, the German counterpart) as it has a core (kern) of nylon strands running the full length of the rope and a protective sheath (mantle) of braided nylon. The most common diameter of rope used by SAR Groups is 11 mm.

Generally, nylon rope is 17% lighter than polyester rope. It is similar in abrasion resistance and flexibility, but is superior in other mechanical properties to polyesters. One disadvantage is that it loses 10-20% of its strength when wet or frozen. Nylon rope of the same diameter (11 mm) used by recreational climbers stretches much more under load and has a static breaking strength of less than 2300 kg.

Rope Care

As rescue rope is our lifeline and our lives literally depend upon it, it is critically important that proper rope management practises are used. While ground searchers are not responsible for performing technical high angle rope rescue, there are occasions when it will be necessary to work under the direction of a Ground Search Team Leader in a rope-assisted stretcher carry.

Dirt

Avoid stepping on ropes. Grit can become embedded in the rope sheath and work its way to the core. Embedded dirt and grit will cut the nylon fibres and compromise the strength of the rope.

UV Radiation

Avoid prolonged exposure of ropes to sunlight. It has been demonstrated that ultraviolet radiation adversely affects the strength of ropes and webbing.

Drying

A wet rope should never be left in a rope bag. Ropes should be dried in a ventilated area and not over a campfire or in a clothes drier. Excessive heat damages the nylon making the rope weaker.

Friction

Nylon on nylon connections should be avoided. Sections of rope moving across stationary rope or webbing is extremely dangerous and can result in the cutting away or melting of the non-moving length of nylon. Do not connect a moving length of rope to a non-moving length of rope or webbing.

Kinks

Rope kinking can potentially result after several rappels, belays or coilings. Unchecked, kinking can turn a length of rope into a search and rescuer's nightmare. Excessive kinking can be avoided by flaking out the rope in a "bird's nest" and taking care to untwist the rope prior to coiling. Avoid introducing any twists while coiling the rope by not coiling the rope around the elbow and over the hand. Instead, allow the rope to fall in its normal pattern, likely a figure eight, to minimize kinking while coiling. It is even better to store the rope bagged not coiled.

Inspection

There is no fool-proof method to determine precisely how much damage has been done to a rope. However, there are indicators of rope damage. Inspection consists of checking the sheath for visible damage. If a section of sheath appears to have been impacted by an object and the core feels unusually soft, immediate retirement should be considered. If the sheath appears abraded due to movement over a rough surface, but no damage to the core has been found on inspection, continued use is possible. Always monitor the quality and condition of the ropes.

If there is ever any doubt regarding the safety of a rope during an inspection, bring it to the attention of the equipment officer. Once the weakness has been confirmed, immediately cut out the damaged section and remove it from circulation.

If the damage is detected during an operation, stop the operation and bring it to the attention of the Ground Search Team Leader or the equipment officer. If removal or cutting is impractical isolate the weakness by tying a Figure 8 on a Bight with the damaged section in the loop of the knot. Mark the knot with a piece of flagging tape.

Washing & Storage

Rescue ropes get dirty with usage and can be washed by hand, in a washing machine or with a rope washer which attaches to a garden hose. To wash by hand, use warm water with a mild soap, rinse and air dry. To wash with a machine, use successive daisy chains around the rope and use a gentle cycle. Check often to ensure the rope does not get tangled in the agitator. Ropes ought to be hung in a cool well-ventilated room in loose coils on large diameter pegs or drying racks.

The best way to store rescue ropes is in a rope bag. The bag protects the rope while keeping it ready for immediate use. The rope length, diameter, and number should be marked on the bag for easy identification. Do not bag wet ropes due to the possibility of mildew.

Rope Log

Every rope should have its' own rope log to keep track of that ropes history. It is important to record any rope use or damage in the rope log to prevent unsafe or outdated ropes from being used.

The 10 Rules of Rescue Rope Care:

1. No stepping on ropes.
2. No dropping rocks on ropes.
3. No ropes moving across rope or webbing.
4. Protect rope from unnecessary abrasion.
5. Wear gloves when working with moving ropes.
6. Inspect the rope after each use.
7. Maintain a rope log.
8. Wash and dry dirty ropes.
9. Coil or bag rope after use.
10. Store ropes where they will not be exposed to UV, high temperatures, corrosives or humidity.

Dynamic versus Static Rope

Dynamic Rope

A dynamic rope is a lifeline or safety line which has elastic properties. Like a rubber band, they stretch under tension. It is designed primarily for lead climbing on snow, rock or ice. It is intended to function as an effective shock absorber to dissipate energy in the event of a fall. This protects both the fallen climber and the anchor.

Dynamic rope is typically between 8.5 mm and 11 mm in diameter and has a 5-8% stretch with a 90kg load. Dynamic ropes are seldomly used in SAR operations as the stretch causes difficulties in the rope systems used by Rope Rescue Teams.

Static (Low Stretch) Rope

Static ropes are used in rescues. Static ropes are stronger than their dynamic counterparts but not as elastic. They will generally stretch 2-4% with a 90kg load.

Ropes used in assisted stretcher carries, embankment or cliff rescues are no less than 11 mm in diameter. Static ropes do not act as a shock absorber and should not be used for lead climbing.

Webbing

Tubular Webbing

Tubular webbing is typically used to fashion an anchor. By wrapping the tubular webbing around the anchor point, it becomes possible to connect a rope to it via a carabiner. Tubular webbing is made of nylon and is considerably stronger than flat webbing. It is the preferred anchor material as its wide surface distributes the load more evenly so as to reduce abrasion and is less expensive than using a rope.

Flat Webbing

The uses of flat webbing are identical to those of tubular webbing but due to its weaker breaking strength is **not recommended for SAR.**

Accessory Cord

Accessory cord refers to any narrow diameter rope made from nylon, Spectra or Kevlar. Accessory cord used in SAR must be no less than 8 mm in diameter. It may be used to make anchors, handlines, prusik hitches or a multitude of other things.

Knots and Bends

If rope forms the backbone for SAR, then knots are the ligaments and tendons that tie it together. The knots used in SAR all adhere to the "**KISS Principle**": **Keep It Simple & Safe**. SAR relies on a few versatile knots. Knot standardization ensures consistency in systems and reduces the number of knots GSAR members are required to know. This lessens the likelihood of incorrectly tying a knot amidst the chaos and confusion of an operation.

The term "Knot" is a general term referring to one of many ways of tying rope either to an object or to itself. More accurately:

- a "**bend**" is a knot that joins two ends
- a "**bight**" is an open loop formed when a rope is doubled back upon itself
- a "**hitch**" is a knot tied to an object such that if the object were removed the knot would fall apart and
- a "**backup knot**" is a knot used to secure the tail of another knot.

Many factors have been considered in deciding which knots will be used in SAR. Strength, ability of the knot to work itself loose in field conditions, ease of tying and inspection, ease of untying after loading, ease of teaching and multi-tasking are all items which have been accounted for.

SAR has adopted the Figure 8 family of knots for its ease of use, adaptability and strength.

All knots should be backed-up with a Double Overhand knot (except the Ring Bend, the Figure 8 Follow Through Bend, and the Italian Hitch) and have a tail at least 10 cm (4") in length. Memorizing what each correctly tied knot looks like will aid in determining whether you have tied the knot correctly.

Dressing and Setting Knots

Dressing a knot is the process of making the knot, bend or hitch "clean" or neat so that the rope flows through the turns. Setting the knot refers to tightening the knot by pulling on the legs of the knot. Cleanly tied and appropriately set knots are easier for the team leader to identify and ensure that they have been tied properly.

Figure 8 on a Bight

This knot is ordinarily used to form a loop to either clip into a carabiner or slip over an object. It can be tied in either the middle or the end of a rope. If tied at the end, it should be used in conjunction with a Double Overhand Back-up Knot.

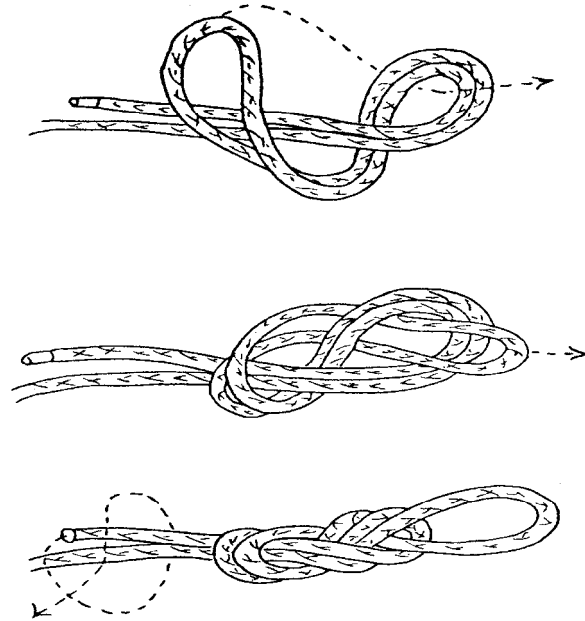

Publisher: ERI Publications Author: ERI and Don Cooper Title: Search and Rescue Fundamentals
 © This material has been copied under licence from CANCOPY. Resale or further copying of this material is strictly prohibited.

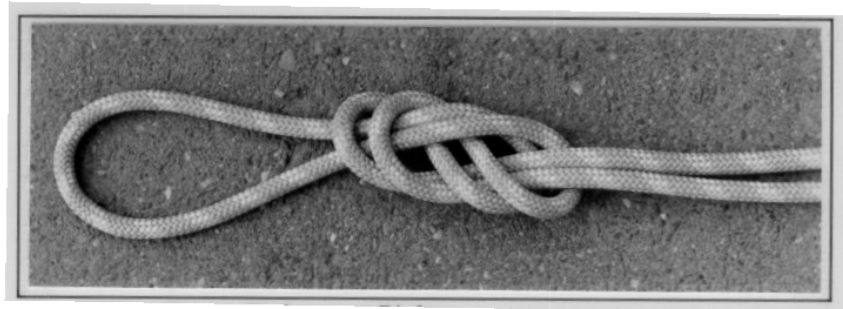
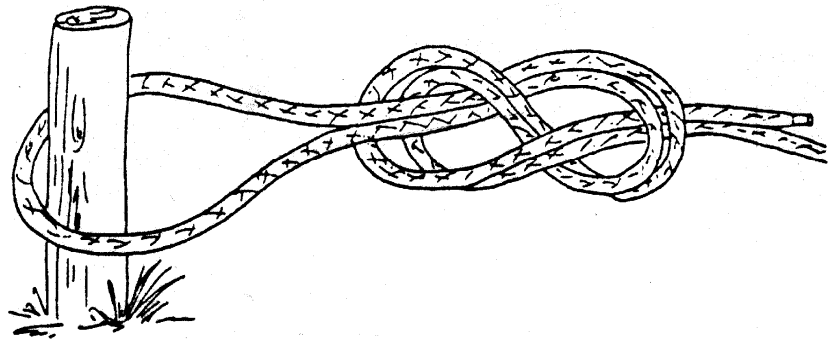
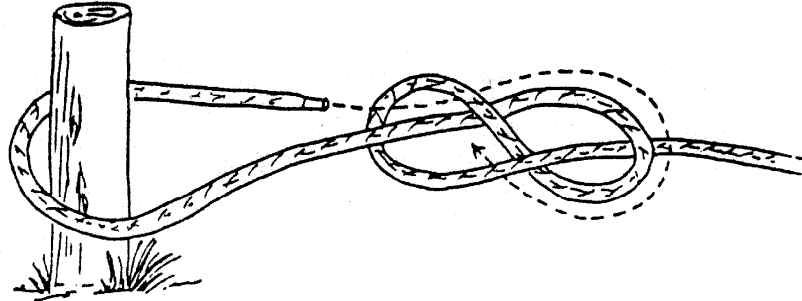

Figure 10.1 Figure Eight on a Bight

Figure 8 Follow Through

This knot is used to tie around an object or into a harness. It must be used in conjunction with a Double Overhand Back-Up Knot.



Publisher: ERI Publications Author: ERI and Don Cooper Title: Search and Rescue Fundamentals
© This material has been copied under licence from CANCOPY. Resale or further copying of this material is strictly prohibited.

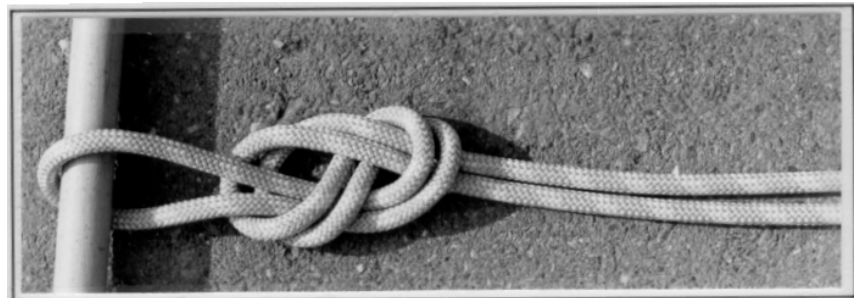
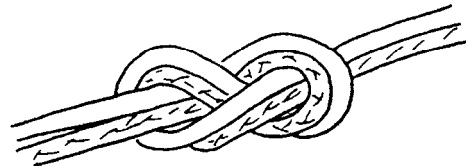
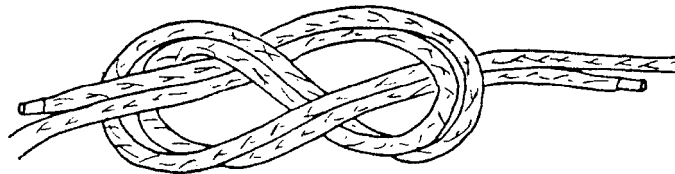
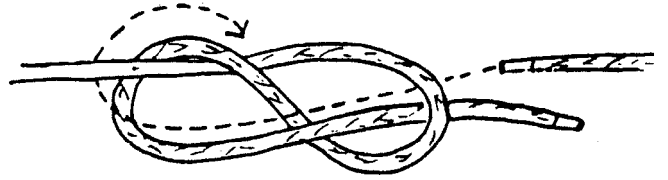

Figure 10.2 Figure Eight Follow Through Knot

Figure 8 Follow Through Bend

This bend is used to tie two rope ends together. No Double Overhand Knots are tied to back it up. Extra care and attention must be taken to ensure that the tails are at least 15 cm (6") in length.



Publisher: ERI Publications Author: ERI and Don Cooper Title: Search and Rescue Fundamentals
 © This material has been copied under licence from CANCEOPY. Resale or further copying of this material is strictly prohibited.

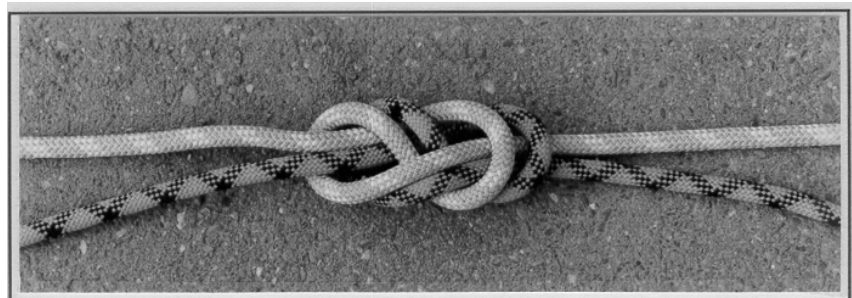

Figure 10.3 Figure Eight Follow Through Bend

Double Overhand Back-up

This knot is used to ensure that a loaded knot does not untie because of rope movement. It is used with a Figure 8 on a Bight (if the Figure Eight on a Bight is tied at the end of the rope) and a Figure 8 Follow Through.

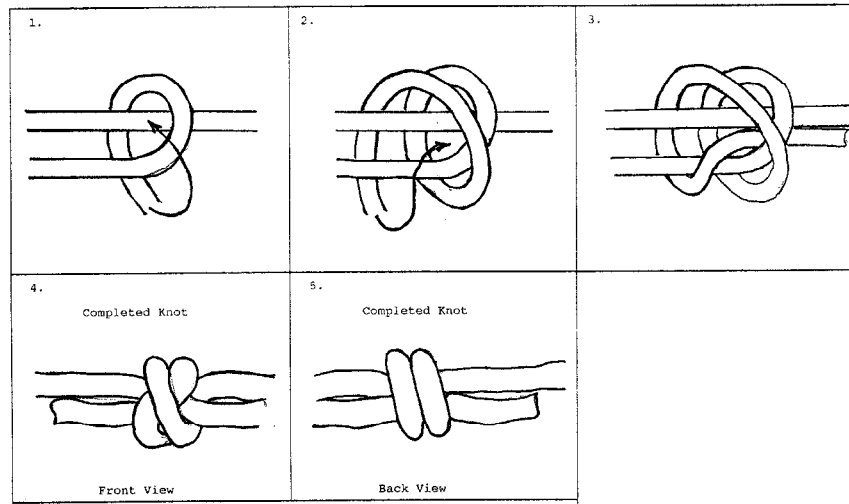
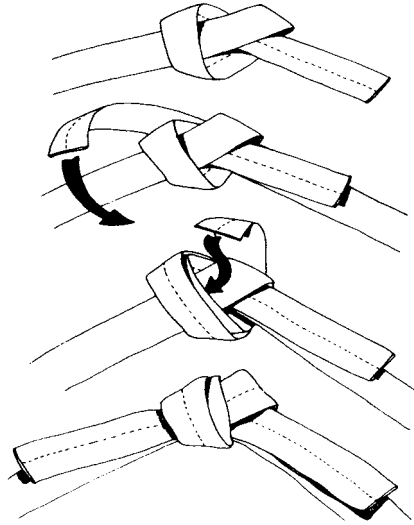

Figure 10.4 Double Overhand Back-up

Ring Bend (Water Knot, Tape Knot, Overhand Bend)

This bend is used to tie two ends of webbing together. No back-up knots are required but make sure that the tails are at least 10 cm (4 inches) long. It is important that the webbing lie flat with no twists and that the knot is set. Do not use the ring bend for tying rope together.



Publisher: CMC Rescue, Inc Author: Frank, James and Patterson, Donald Title: CMC Rappel Manual
 © This material has been copied under licence from CMCOPY. Resale or further copying of this material is strictly prohibited.

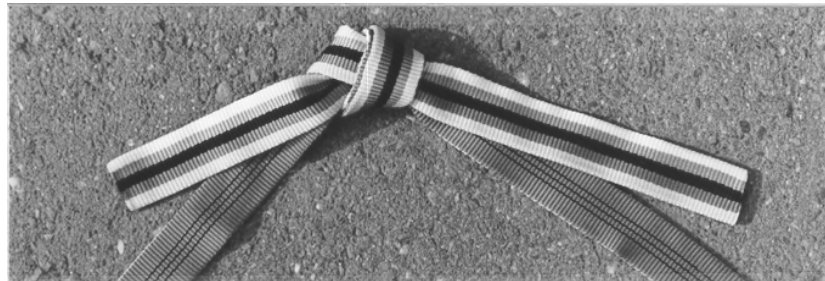

Figure 10.5 Ring Bend

Italian Hitch

The Italian Hitch (Munter Hitch) is usually used to belay single-person loads. It may also be used for belaying stretcher teams on low angle slopes. An Italian Hitch is unsuitable for belaying multi-person loads in any technical terrain where the rescuers would slide or fall if the belay gave way.

An Italian Hitch must be used with a locking carabiner, preferably a pear-shaped or "Offset D" one. An Italian Hitch will impart a twist to the rope making the rope more susceptible to tangling.



Figure 10.6 Italian Hitch

Carabiners

A carabiner is a snaplink that connects different elements of a rescue chain such as a rope to an anchor. Carabiners may be constructed of aluminum or steel and come in a variety of sizes and shapes. The larger the gate opening to the carabiner, the easier it is to connect things to it.

Carabiners may be oval-shaped, pear-shaped or shaped like a "D". They are strongest when the load is applied along their spine. Designs which hold the rope or webbing along the spine are preferred, ie. "D" or offset "D" carabiners. Their gates may be non-locking or locking. There are many different carabiner locking mechanisms: screw gate, reverse screw gate, spring-loaded or twist gate, or double autolock.

Carabiners used in rescue may be either aluminum or steel and must have a locking gate.

As with any hardware, carabiners must be treated with respect. They must be placed on the ground (**not dropped**) and passed to one another (**not tossed or thrown**). Should a locking carabiner become jammed so that it cannot be unlocked, apply a constant force to the carabiner and attempt to unscrew the gate while loaded. If this does not work, use pliers.

Anchors

An anchor is an immovable object to which the rope is attached. If an anchor is required, a Ground Search Team Leader will select what object will be used. Some examples of anchors are trees, rocks and vehicles. The following discussion will introduce you to some of the factors that the Team Leader considers when selecting an anchor.

When anchors are chosen they should be “bombproof”. That is, they will never move. A tree has to be alive, well rooted, and immovable. It must not flex or bend when pushed near the base. Tie off at the base and not high up on the tree.

Rocks have to be immovable and the abrasion points well padded. Vehicles should be parked perpendicular to the direction of the load, webbing tied to the frame and padded, doors locked, transmission engaged, emergency brakes on and wheels chocked.

Looped Sling Anchor

For assisting a rescuer or stretcher team up or down low angle slopes, a single “bombproof” anchor is acceptable.

This type of anchor can be constructed in two ways. One method is to wrap a length of sewn webbing or loop of webbing whose ends are tied with a ring bend around an anchor and clip the loops with a locking carabiner (Figure 10.7a). Another method is to wrap an untied section of webbing around the anchor, tying the ends with a ring bend and clipping the flat section with a locking carabiner (Figure 10.7b).

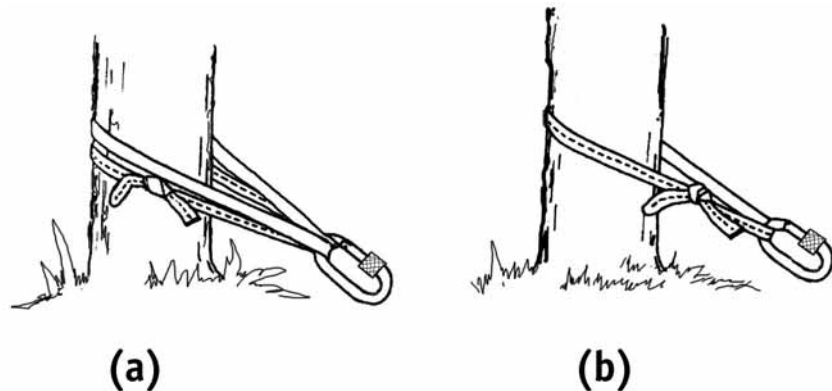

Figure 10.7 Looped Sling Anchor

It is important to keep the angle at which the two legs of the sling meet the carabiner at less than 90°. This is achieved by having a long enough sling that the carabiner is positioned out from the anchor.

Also, try to keep the webbing close to the base of the anchor to avoid any leverage on the anchor.

Hand lines

A rope may be used to create a hand line that can be used to assist a person moving up or down low angle slope. This would be most useful during demobilization when searchers are tired and may be carrying large packs.

A hand line is created by tying a rope around an anchor using a Figure 8 Follow through or clipping one end of the rope to a simple slung anchor using a Figure 8 on a Bight.

Hand loops can be added to the rope by tying overhand or Figure 8 on a Bight knots with loops that are 15-25 cm long.

Belaying with an Italian Hitch

An Italian Hitch can be used to belay a rescuer or stretcher team while it is raised or as it is lowered on low angle slopes.

1) To belay a load as it is raised:

- The lead hand holds or guides the rope going to the load.
- The rope then passes through the Italian Hitch on the locking carabiner at the anchor.
- The brake hand does not leave the brake end of the rope.
- The lead hand does all the manipulating and movement to take in rope.
- If the belayer is facing the load:
 - Step 1 – Pull back with the lead hand and forward with the brake hand.
 - Slide the lead hand ahead of the brake hand and hold both ropes.
 - Slide the brake hand towards the Italian Hitch without taking it off the rope.
 - Bring the lead hand back in position so it can pull in more slack.
 - Go back to step 1 and pull back with lead hand and forward with brake hand.
- If the belayer is facing the anchor:
 - Step 1 – The lead hand is pushed forward towards the Italian Hitch as the brake hand is pulled back.
 - The lead hand is slid away from the Italian Hitch to a position below the brake hand and holds both ropes.
 - Slide the brake hand towards the Italian Hitch without taking it off the rope.
 - Move the lead hand away from the Italian Hitch on the load end of the rope and into position to take in more slack. Repeat from step 1.

Belay Signals

2) To belay a load as it is lowered:

- The end of the rope not going to the load (brake end of rope) is fed into the Italian Hitch by the lead hand. The brake hand also holds the brake end of the rope. For greater control it is possible to hand-over-hand the brake end of the rope so that one hand is always on the rope at any one time.
- Should the rescuer slip or fall, throw the brake hand in alignment with the load line.

Efficient communications are an important part of any evacuation. The following commands are used to assist the belaying of a stretcher team down a low angle slope.

Communicator	Command	Translation
Ground Search Team Leader (GSTL)	ATTENDANTS READY?	Are the stretcher attendants ready to move.
Stretcher Attendants	READY	Ready to move.
Or		
Stretcher Attendants	STANDBY	Not ready to move.
GSTL	BELAY ON?	Is the stretcher on belay?
Belayer	ON BELAY.	I am in belay position and ready to belay.
GSTL	LOWER AWAY	When the stretcher starts to descend.
Belayer	LOWERING AWAY	I am expecting the stretcher to move and will begin letting out rope.
GSTL	RAISE	When the stretcher team starts to move.
Belayer	RAISING	I am expecting the stretcher to move and will begin to take in slack.
GSTL	SLACK	When rope is needed.

GSTL	TENSION	When a tight belay rope is needed.
GSTL	SECURE	When stretcher team is secure.
Belayer	BELAY OFF	When belay is off.
Anyone	STANDBY	If not ready to proceed.
Anyone	STOP	To stop the operation immediately.

Final Comments

It must be stressed that the techniques that have been discussed in this chapter are only to be used to assist movement up and down low angle slopes (slopes on which dropping to the ground would not result in movement down the slope).

A Rope Rescue Team using rope rescue techniques is required if a person would slide or fall if they slipped.

Additional Reading

Provincial Emergency Program, Justice Institute of BC, Emergency Management Division. *Ground Search Team Leader Manual*. 1997

Provincial Emergency Program, Justice Institute of BC, Emergency Management Division. *Rope Rescue Manual*. 1992

Further references listed in the Bibliography.

Chapter Review

Please answer the following questions on a separate sheet of paper so that another student can use this manual. The answers to these questions are located at the end of the manual.

1. What is the difference between a dynamic rope and a static rope. Which one is used in SAR?
2. When is a single point anchor acceptable?
3. Which hand must never leave the rope when using an Italian Hitch?
4. If you are the belayer and you say "On Belay" what does that mean?
5. Be able to tie all the knots and bends described.

Answer **True** or **False** to the following statements.

6. A ring bend must have tails at least 4 cm long.
7. Flat webbing is recommended for SAR work.
8. A ring bend is used to tie two pieces of webbing together.
9. A Double Overhand Back-Up Knot is used with a Figure Eight Follow Through Bend.
10. After finishing this chapter you are ready to conduct technical rescues.



Chapter 11 - Orientation to Tracking

Upon completion of this chapter, you will be able to:

- Define clue, sign and track (print).
- Describe the use of tracking in SAR.
- Be aware of sign.
- Preserve sign.
- Describe a tracking stick and its use.
- Describe techniques used by a tracking crew.
- Explain how a track is labeled.

Introduction

Over the years tracking has been shown to be a very effective technique in locating lost persons. Tracking (sign cutting) is the step by step following of a person. It takes training, determination and hundreds of hours of practice to become a skilled tracker.

The skills required for tracking and for sign cutting are beyond the GSAR Course. However, GSAR team members without training in tracking still need some knowledge of what these skills are in order to assist trackers.

In this section, only a basic understanding of what is involved in tracking will be covered. Tracking can not be learned from a book, only hours of practice will make a person competent in tracking. In BC, there are a series of courses available for people who are interested in increasing their tracking skills. The courses are set up in progressive levels of proficiency starting with Tracking Aware followed by Tracker 1, Tracker 2 and Sign Cutter. These courses are delivered through Universal Tracking Services.

Clue Awareness was covered in the Initiating the Search Chapter and should be reviewed at this time.

Definitions

Clues

Clues are objects, information, or some form of evidence that helps locate a missing person.

Cutting for Sign

Cutting for sign is a process of looking for sign usually along natural barriers such as creeks, banks, or roads.

Sign

Sign is the evidence of a person's passage. This can be visible tracks, compressed ground, moisture knocked off of grass, damaged leaves, dirt transferred onto plants or many other things.

Track or Print

A track (print) is the impression left in the ground as a subject past over an area. A signature print is a footprint displaying characteristics that make it unmistakably identifiable.

Tracking (sign cutting)

Tracking is the step by step following of a person.

Track Trap

A track trap is an area that is especially good for finding sign.

Tracking Team

A team of three, each with a specific function, following a line of sign.

Use of Tracking in SAR

When tracking is used early in the search, the search area can be significantly reduced. Tracking teams cut for sign around the point last seen, last known position or initial planning point until a signature track is found. Finding a signature track may be one of the most difficult parts of the search especially if many people have crossed the search area.

Tracking teams then follow the tracks to determine the direction of travel. By finding the direction of travel the high probability search area is now reduced to a wedge shaped area instead of a circle.

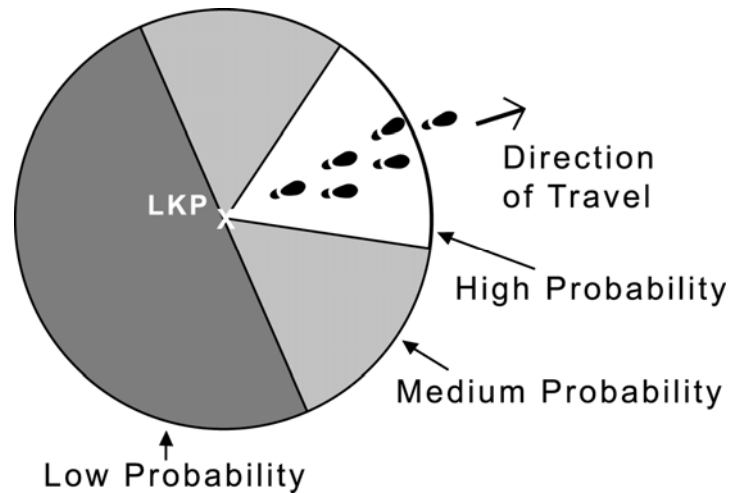

Figure 11.1 Search Area Reduction by Establishing Direction

Tracking teams may then follow the subject's trail step-by-step. The sign they follow may be visible tracks or may be slight indications of travel such as overturned pebbles, crushed grass or dew knocked off leaves. Progress may be quite slow going step by step.

If another team of advanced trackers is available, the process of cutting for sign is used to speed up movement along the subject's trail. This second team of trackers will look for sign while moving across the projected line of travel at 90°. This will determine if the subject continued in that direction. If they find identifiable sign, they take over moving from track to track and the original team now moves ahead to cut for sign. This allows the trackers to "leap-frog" ahead on the missing person's track (Figure 11.2)

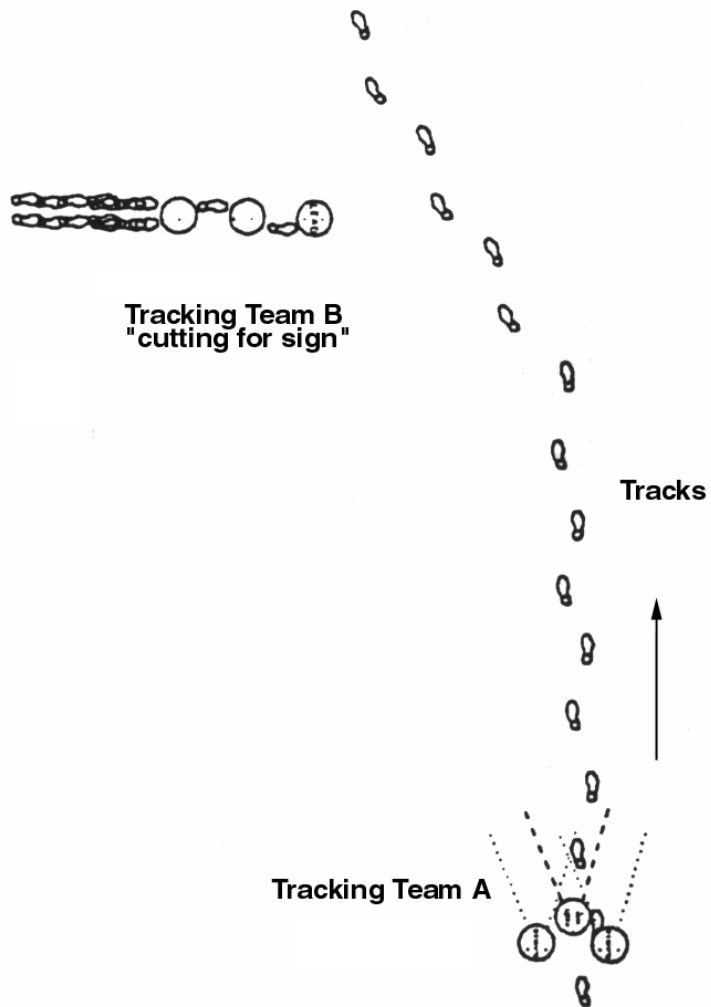

Figure 11.2 Cutting for Sign

If no sign is detected and the sign cutting team is highly skilled, it may be concluded that the missing person has not passed this way and has either changed his or her direction or has stopped somewhere between the cutting line and the last identified track.

Sign Protection

Inexperienced searchers can easily destroy sign by trying to cut for sign. They can also miss sign that is present but not obvious. This can lead to incorrect assumptions about the subject's location.

Cutting for sign is only to be attempted by experienced trackers.

It is important for every searcher to try to prevent sign from being damaged or destroyed. Once sign is destroyed there is no way to bring it back. For example, if a search is starting at the missing subject's vehicle, the area around the vehicle should not be walked on. This is the most likely area to find a signature print and a direction of travel. If the car is to be checked, a single travel line coming from the rear of the vehicle should be used to access the driver side of the car and the access route should be marked.

Experienced trackers may also cut for sign along trails, roads, creeks or any other track traps to determine if the subject went in that direction. This is called a perimeter cut and can vastly reduce the search area by determining where the subject has not been. Searchers should also be looking for sign anytime they are traveling down any pathways.

Even though GSAR trained personnel are not as sign aware as a trained tracker, they should still always be looking for sign anytime they are traveling down a trail, road or through the bush.

EQUIPMENT FOR TRACKING

Tracking Stick

A tracking stick is an invaluable tool for the tracker. It is used to help focus the trackers attention on an area of ground most likely to have the next track.

Tracking sticks are used to measure track size (length of foot) and the distance of a person's stride (from the toe of one track to the heel of the next track). They can be made from anything that is available such as ski poles, branches, or a section of an avalanche probe. Rubber O-rings are placed on the tracking stick and can be adjusted to mark the two measurements.

How Trackers use a Tracking Stick

Experienced trackers will use a tracking stick when two tracks can be positively identified. The tip of the stick is placed in line with the rear of the front heel print. A rubber O-ring is placed on the stick where it lines up with the toe of the rear print. This is the stride measurement. The tracker also places a rubber O-ring at the heel of the rear foot. This is the foot measurement. The tracking stick is held over the known tracks not on the ground. This prevents damage to the tracks.

The tracker searches for the next track by pivoting the stick with the toe marker lined up with the toe of the last known track. She concentrates on the area at the tip of the tracking stick as this is the prime sign area. The tip of the tracking stick is moved from the 10 o'clock to 2 o'clock position above the toe of the last print. The next heel mark should be in that area. It may be very obvious or it may be almost impossible to see. The tracking stick is used to focus the tracker's eyes on the prime sign area so that minor details will be seen. It takes considerable practice to train your eyes not to wander off of the prime sign area.

Moving from one well-defined obvious track to the next well-defined obvious track without finding the tracks in between is called jump tracking and is avoided by trackers. The process of jump tracking destroys sign and makes it very difficult to retrace the steps if the tracker moves off onto the wrong course. This is a common error of beginner trackers.

Tape Measure

A tape measure is used to measure various dimensions on a print. The dimensions are used to compare different prints.

A Note Pad

A note pad is important to record print measurements and to draw a print picture.

Flagging Tape

Flagging tape is useful in marking sign and marking off areas to prevent sign damage. Make sure it is removed after use.

Flashlight

Light and light angle plays an important role in viewing tracks. A flashlight can be useful in sub-optimal lighting.

The Effect of Light

Light plays an important role in how well tracks can be seen. The low angle light in the morning and evening is the best light for viewing tracks. The longer shadows make slight depressions easier to see. Having the light source directly in front of yourself also makes the tracks easier to see. However, do not damage sign trying to get the sun in the right position.

At night, the tracker controls the light source and this proves to be an excellent time to find sign. The tracker's attention is focussed on the small area of light on the ground enabling her to concentrate and see more detail than in daylight. The tracker can also control the strength of the light source and the angle at which it hits the ground. A diffuse light source directed at a low angle to the ground is the best for seeing sign.

Tracking Teams

Once a signature print has been found the tracking team may start step by step tracking. Tracking teams are made up of three members, a point person and two flankers. The point person stays behind the last print found and uses the tracking stick to search for the next print. The two flankers are on either side of the point person and they watch for change of direction of the trail, any incoming trails that may confuse the point person and help the point person find the next track.

The point person requires extreme concentration that cannot be maintained for a long period of time. The flankers should alternate into the point position frequently. Exchanging ideas between the tracking team is important so that no sign is overlooked.

Labeling Tracks

If, during the course of a search you come across tracks, these tracks should be labeled and care taken not to damage them. If an entire print is visible a circle can be drawn around the print while flagging tape may be used to identify where the track is. Search base should be notified about the track and given the track identification information as outlined below. If it is raining or very windy the track should be protected by carefully placing a tarp over the track.

Track Identification

The sole of every shoe has an identified pattern. This variation in patterns is beneficial to the tracker as distinguishing between different tracks can be a difficult process. All searchers should be able to describe a sole pattern over the radio.

Trackers identify tracks using some basic information such as:

Track Measurements

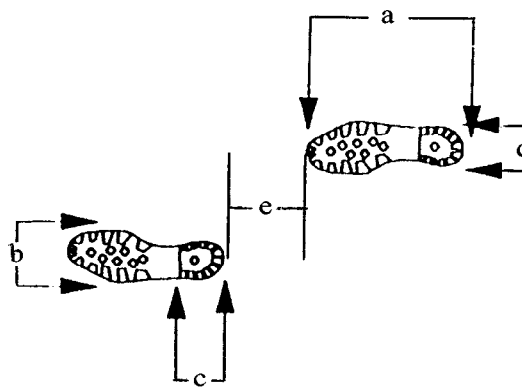

- (a) Length of print
- (b) Width of ball of foot
- (c) Length of heel
- (d) Width of heel
- (e) Length of Stride

Figure 11.3 Track Measurements

Shoe Type

There are many different shoe types and only a sample of the more common types is represented here.

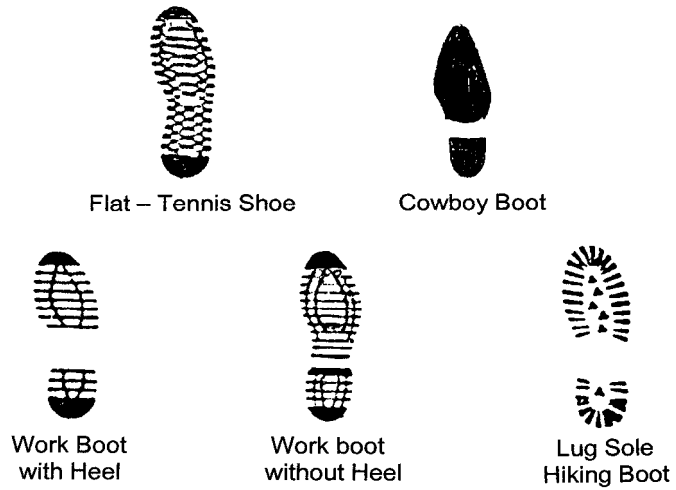

Figure 11.4 Shoe Types

Shoe Shape

- Toe – round, pointed or square
- Heel – straight leading edge, concave leading edge

Basic Sole Pattern

As with shoe types there are many different types of sole patterns and the best way to convey what the pattern looks like and remember what it looks like is to draw it.

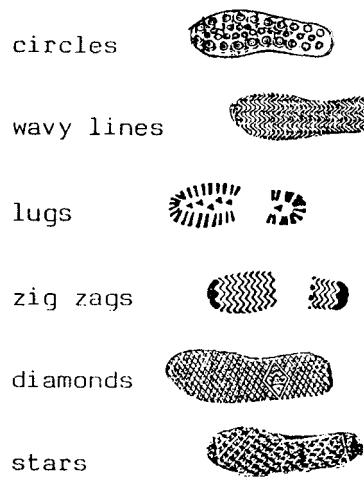

Figure 11.5 Basic Sole Pattern

Unique Features

- Worn areas
- Cuts

Track Report

A track report form such as the one shown in Figure 11.6 can be used to communicate what the track looks like to others, to differentiate the track from other tracks and it keep a record of the track for future use.

Universal Tracking Services Inc.

TIME: _____

* LOCATION: _____

* SUBJECT HEADING: _____

* BASIC TYPE _____

* PATTERN _____

DIMENSIONS - OVERALL:

* L _____ W _____

HEEL:

L _____ W _____

STRIDE (TOE TO HEEL): _____

GROUND: _____

REMARKS: _____

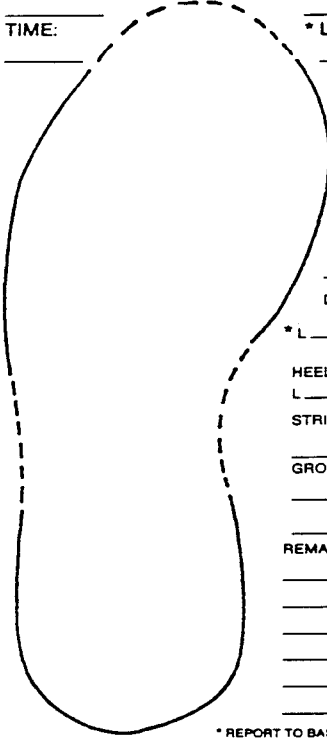

* REPORT TO BASE

Figure 11.6 Track Report

Final Comments

The theory of tracking and sign cutting is fairly easy to describe. Its practice is the opposite. Spotting sign is very difficult and only very experienced trackers can state with confidence that no sign is present. Much practice is essential to use the technique effectively. It is not for the use of inexperienced searchers.

Additional Reading

Hardin, Joel. *Universal Training Systems Signcut Division (Manual)*. Everson, WA.

Cooper, Donald C. and Taylor, Albert "Ab". *Fundamentals of Mantracking: The Step-By-Step Method, 2nd Edition*. Olympia, WA: Emergency Response Institute, Inc. and National Rescue Consultants, Inc., 1993.

Kearney, Jack. *Tracking: A Blueprint for Learning How*. El Cajon, CA: Pathways Press, 1978.

Further references listed in the Bibliography.

Chapter Review

Please answer the following questions on a separate sheet of paper so that another student can use this manual. The answers to these questions are located at the end of the manual.

1. Why do GSAR trained members need to know about tracking?
2. Why is night a good time to track?
3. What type of information is important for track identification?
4. What is the key to becoming a good tracker?

Answer **True** or **False** to the following statements.

5. Base should only be informed at search team debriefings about tracks that are found.
6. The search area can often be reduced when a tracking team is used early in a search.
7. Tracks and sign are the same thing.
8. Jump tracking is used to move along a subject's trail.



Chapter 12 - Helicopter Safety

Upon completion of this chapter, you will be able to:

- Outline the advantages and disadvantages of using helicopters and aircraft for SAR operations.
- Perform duties safely in the vicinity of helicopters.
- Describe some of the requirements for helicopter landing zones.
- Demonstrate correct procedures when boarding and deplaning from helicopters.
- Demonstrate correct procedures when acting as an air operations observer.

Helicopter Use in SAR

Helicopters are used in SAR operations for two main tasks: to move crews and equipment to the search area and to evacuate injured subjects. They have been increasingly used in SAR because of their speed and maneuverability. Even though they are a valuable resource they do have some disadvantages. Disadvantages include cost, physical limitations (i.e. payload capacity), inability to function in bad weather or at night, and difficulty communicating with ground teams.

High velocity rotors present safety hazards that must be respected. The rules that will be outlined in this chapter are to ensure that GSAR team members work safely around helicopters.

There are a number of different models of helicopters in use and these vary in their seating capacity, allowable payload, required landing pad size, and stretcher loading capabilities and procedures. The GSAR member does not need to have a detailed knowledge of all the different models of helicopters but should become familiar with the helicopters that are used in their area.

SAR groups sometimes have an over-reliance on helicopters and this should be avoided. Valuable time can be lost while waiting for weather to improve for helicopter flight or waiting for the arrival of the helicopter. Back up plans should always be in place in case the helicopter cannot be used.

Helicopter Safety

As a GSAR team member, you may be present on a task where helicopters are used, the following must be followed to work safely around helicopters.

- All GSAR team members and bystanders who are not part of the crew working directly with the aircraft must stay 35 metres (120 feet) away from the aircraft.
- A member should be assigned to maintain site security. This person would ensure that everyone except those boarding the helicopter are 35 metres away. They would also ensure that the helicopter is approached only in a safe manner.
- Do not load without the pilot's or other authorized crew member's permission and supervision.
- Always approach or leave a helicopter from the front so the pilot can see you at all times (Figure 12.1).
- Keep your head down at all times but look forward so you can see where you are going.
- Never touch an external load, hook or any part of the helicopter until it has made contact with the ground due to the buildup of static electricity.

- Never approach or leave a helicopter from any side where the ground is higher in relation to where the helicopter is resting.
- No smoking within 35 metres (120 feet) of the helicopter.
- Maintain a wide clearance from the tail area and the tail rotor.
- Headgear should have chinstraps. Loose clothing or equipment (ropes, sleeping pads, parkas etc.) must be secured and not be left around the landing zone.
- Long handled tools (ice axes, skis, shovels etc.) must be kept parallel to the ground when approaching or leaving a helicopter.
- In soft ground terrain (eg. snow, swamp) do not stand on the skid of a small helicopter when exiting or entering the aircraft.
- Have appropriate clothing for conditions outside while flying in a helicopter in case an emergency landing has to be made.
- If you require medications, bring extra with you in case flight plans change.
- No items such as bear spray, bear bangers, or explosives are allowed in the passenger compartment.
- Goggles can be worn to protect eyes from flying debris.
- Never stand below a helicopter when it is slinging equipment unless you are part of the loading operation.

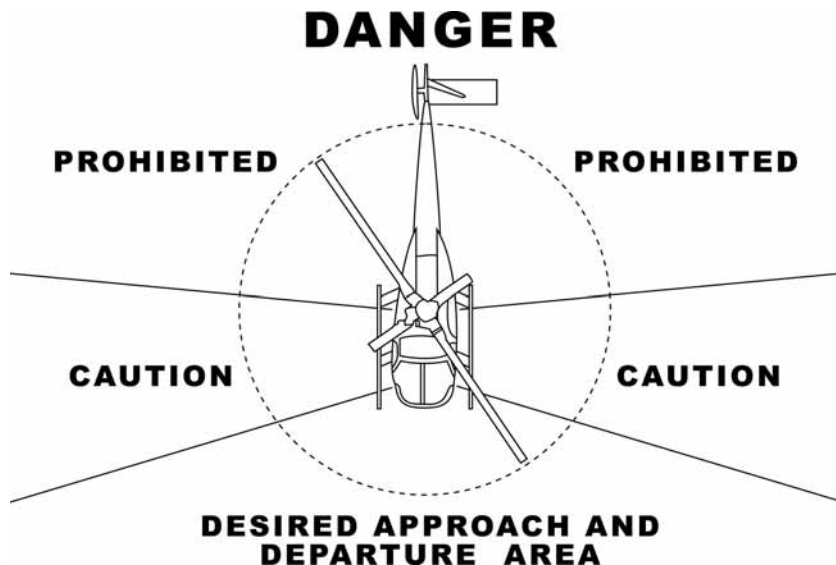

Figure 12.1 Helicopter Approach Zones

Landing Zone Guidelines

If helicopters are going to be used on a task then landing zones have to be found or built.

A good landing zone provides enough cleared space for a helicopter to safely land and take off into the wind. Vertical landings and takeoffs require more power reducing safety. Therefore, elongated landing and take-off lanes should be oriented parallel to the wind direction. The size of clearing required will vary depending on the type of helicopter being used. In general you will want to have a distance of 50 m from the end of your landing zone to the first 15 m high object in the flight path. (See Figure 12.2)

The touchdown pad should be level, firm, clear of debris and have nothing sticking up more than 30 cm. Wires are difficult to see from an aircraft so the location of the landing zone should be well away from any wires.

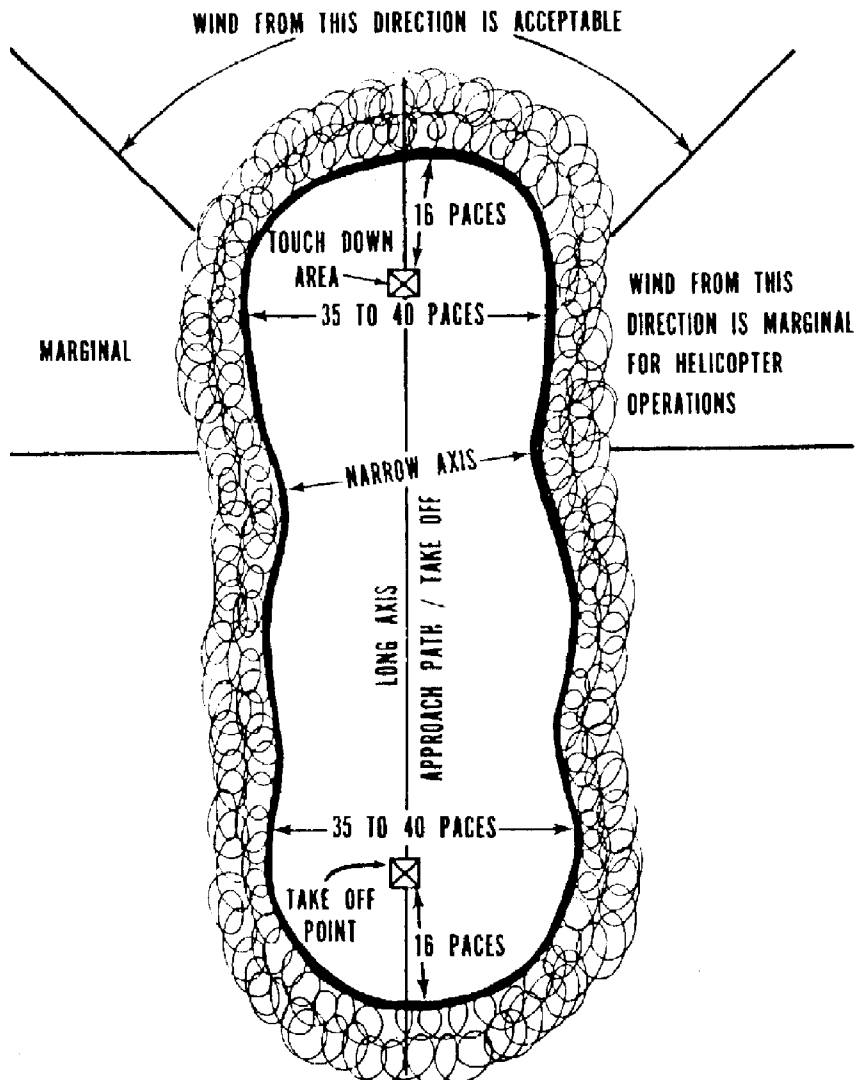

12. 2 Helicopter Landing Zones

The best landing zones are located on the top of ridges, hills or other exposed areas. The final decision on whether to land the helicopter is the pilots and he may decide to land somewhere else. It is then important to have good communication between the ground team and the helicopter.

To indicate wind direction to the incoming helicopter use a smoke flare, wind indicator (brightly coloured clothing) or light a small smoky fire 50 meters away from the landing zone (watch out that it is not too close as the rotor wash can easily spread the fire).

Keep clear of the landing zone when the helicopter lands. Dust, snow, or anything loose will be blown toward you by the rotor draft. Crouch down to the ground 30 metres (100 feet) away and/or turn your back from the helicopter. Eye protection can be useful.

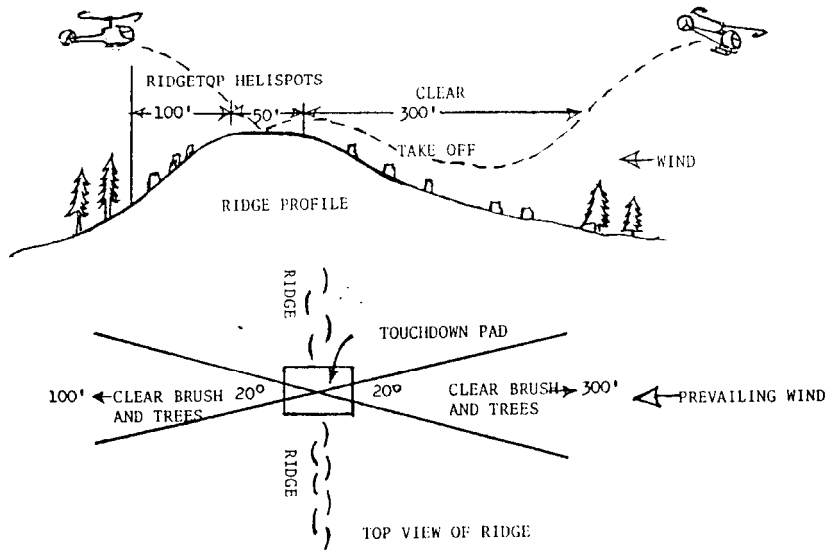

Figure 12.3 Locating Helicopter Landing Zones

Preparation of a Landing Site on Snow

To prepare a landing site on snow, pack the snow level with snowshoes, skis, feet or a snowmobile. Pack the snow at least half an hour before the helicopter arrives so that the snow can harden.

If the snow is extremely soft, and cannot be compacted, further support for the helicopter should be provided.

- Build a mat of spruce boughs 3 m square and 15 cm thick.
- Lay five or six strong, trimmed logs each 2 ½ to 3 m long on the mat at 0.5 m intervals and at right angles to the helicopter approach. Ensure the logs will not roll.

Landing Sites on Soft Swampy Ground

On soft, swampy ground a landing site similar to that described for extremely soft snow could be made.

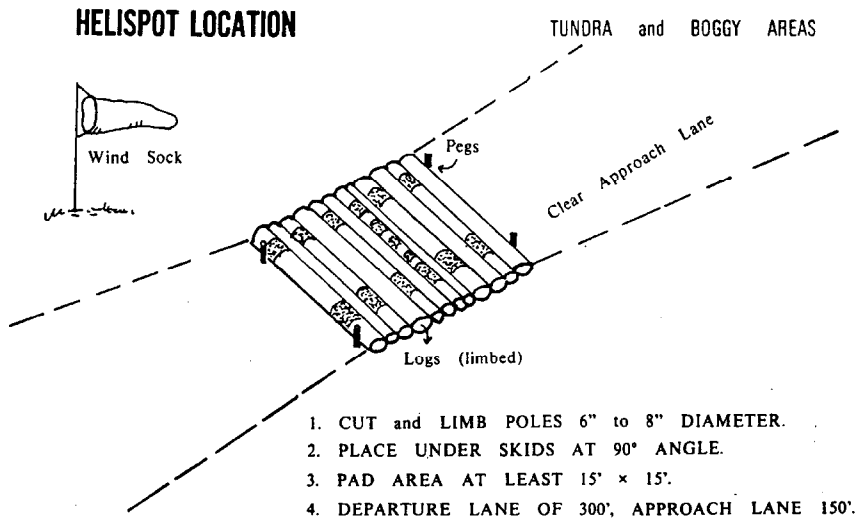

12.4 Helicopter Landing Zone on Snow

Boarding a Helicopter

Before the helicopter arrives the Ground Search Team Leader should go over the boarding plan with the team. Details such as where the team will wait for the helicopter, the order in which team members will board, who will stow gear, and any safety considerations should be reviewed. Plans for exiting the helicopter after the flight should also be discussed at this time.

The pilot may shut down the engine before loading or he may leave the engine running and the rotor turning. Loading while the engine is running requires considerable care and attention to safety.

Only those who will be loading need to be close to the loading area, everyone else should keep clear. As the helicopter approaches, crouch down at the edge of the intended landing area with all loose items secured. Loose items can be drawn up into the moving rotors or jet intakes causing damage to the helicopter. In severely cold weather make sure all your skin is protected to prevent frostbite occurring from the rotor wash.

Approach the helicopter from the front only when the pilot gives you a positive signal that it is safe to do so (usually an exaggerated nod of the head as the pilots hands are busy and he may not be able to wave). Never approach from the rear as under some conditions the moving tail rotor cannot be seen. People have been killed walking into the tail rotor.

Remember: if you can't see the pilot's eyes you are in the wrong place.

Approach the helicopter from lower ground. **Never approach from the uphill side** as this puts you closer to the rotor.

Keep low when you approach the helicopter as the blade will drop lower when the pilot cuts power. Look ahead as you approach in this crouched position, not at the ground.

Do not go under the tail boom to get from one side of the helicopter to the other.

Carry tools and equipment horizontally at waist height.

Open the door hold, place packs and cargo on the floor then climb slowly aboard one at a time.



Publisher: CFS Press Author: S. Ray Title: Swiftwater Rescue

© This material has been copied under licence from CANCOPY. Resale or further copying of this material is strictly prohibited.

Figure 12.5 Do not approach a helicopter from an uphill slope. Enter and exit downhill.

In the Helicopter

- Ensure that all seat belt ends are inside before closing the door. Gently pull the door shut. **Do not slam the door.**
- Wear your seat belt including the shoulder straps if provided.
- Wear the headset, and ask the pilot how to use it before taking off. Do not talk to the pilot during takeoff or landing. Don't forget to remove the headset when you deplane.
- Remain in your seat unless given permission to move.
- Do not distract the pilot during takeoff, maneuvering or landing.
- Do not let items contact the plexiglass windows and do not touch the window surfaces.

Single Skid Landing

Under some conditions the pilot will not be able to completely land the helicopter. In this case, one skid may be put on the ground while the other skid is still in the air and the pilot maintains the position by hovering. Landing during a single skid landing requires a gradual placement of weight onto the helicopter allowing the pilot to adjust for this new weight.

Exiting the Helicopter

On the approach to the landing site the helicopter pilot may advise you on hazards that he may see, where he wants you to exit to and he may confirm your pick up point and time.

The pilot will indicate when you can exit (deplane).

Remove headset and seatbelts.

Exit one at a time on the side opposite the pilot unless told otherwise. Move slowly, hand out gear and reconnect your seat belt before exiting.

Once out of the helicopter, secure the door and crouch down at the side of the helipad with your equipment. **Never depart uphill from the helicopter.** The Ground Search Team Leader will give the all-clear signal to the pilot. Wait until the helicopter has lifted off and cleared the pad before moving equipment away.

Air Operations Observer

To be a spotter in an air search conducted by CASARA (Civil Air Search and Rescue Association) or Rescue Coordination Center search aircraft formal training is required. However, SAR team members are occasionally required to be observers from an aircraft or a helicopter. In addition, if you are being transported to a search area by helicopter or aircraft, the time in the air can be spent spotting. There are some basic skills that should be known to be an effective observer.

Being an observer takes considerable concentration and the length of time that a person is effective is only 2 to 3 hours. Techniques which make the observer more efficient are:

- making sure that the window is clean,
- having a comfortable position,
- having the lights off in the aircraft,
- using binoculars only to investigate naked eye sightings
- communicating only when necessary.

Visual coverage of the search area is best achieved by setting up a scanning pattern with the eyes. As the aircraft moves forward scan slowly back and forth at right angles to the flight path. Try to move slowly from one point of focus to the next and pause briefly at each focal point. Moving the whole head instead of just the eyes can prevent eyestrain.

Additional Reading

Any sign that you observe should be mentioned to the pilot so that a closer inspection can be performed. Signs would include anything out of the ordinary such as tracks, tents, vehicles, signals (lights, flares), shiny objects or movement. Any sign or lack of sign should be documented in a log that can be given to the SAR Manager and used for future planning.

Provincial Emergency Program, Justice Institute of BC, Emergency Management Division. *Ground Search Team Leader Manual*. 1997
Further references listed in the Bibliography.

Province of British Columbia, Ministry of Forests. *In and Around Helicopters - Passenger Safety*.

Workers' Compensation Board. *Safe Work Practices for Helicopter Operations in the Forest Industry*. Richmond, BC, 1995

Chapter Review

Please answer the following questions on a separate sheet of paper so that another student can use this manual. The answers to these questions are located at the end of the manual.

1. How far away from a helicopter should GSAR team members who are not loading stay?
2. Describe how you would load during a single skid landing.
3. Never approach a helicopter from _____ or from _____.
4. For SAR in BC, what are the two main tasks that helicopters are used for?
5. Why should the back of the helicopter be avoided?
6. Describe how to achieve the best coverage of a search area as an air operation observer.

Answer **True** or **False** to the following statements.

7. You should approach the helicopter as soon as it lands.
8. Elongated landing zones are the best shape for helicopter operations.
9. Always use binoculars when scanning from a helicopter or aircraft.
10. The GSTL has the final decision on where the landing site will be located.



Chapter 13 - Avalanche Orientation

Upon viewing of the avalanche video, you will be:

- Aware of the avalanche hazards that exist on snow slopes.

**Avalanches
and SAR**

Snow kills. Every year 10 people on average are killed in avalanches in BC. Hundreds of SAR personnel are annually involved in performing winter searches however, it is beyond the scope of the GSAR Course to provide instruction for safe winter backcountry travel and avalanche response. The objective of watching the video “Beating the Odds” is to increase your awareness of the potential and probable hazards that are present during snow travel.

It is PEP policy that for any avalanche SAR response the Site Safety Officer is a Canadian Avalanche Association (CAA) Level II Technician and that the SAR Team Leader, and preferably all volunteers involved should have completed the Justice Institute of BC (JIBC) Organized Avalanche Response Course.

Furthermore, many SAR Groups in BC are often conducting SAR operations in areas containing avalanche terrain. These groups should make it a priority for their members to take the Organized Avalanche Response Course.

CAA Certified Avalanche Technicians may be accessed through the Ministry of Transportation and Highways, the CAA or from local outdoor commercial operators such as ski hills.

**Additional
Resources**

Organized Avalanche Response Course, Justice Institute of British Columbia

Canadian Avalanche Association web site at <http://www.avalanche.ca>

Chapter 14 - Evacuation

Upon completion of this chapter, you will be able to:

- Identify the type of terrain over which evacuation is possible as a ground search and rescuer.
- Be familiar with the equipment your SAR Group uses.
- Assist the first aid attendant with patient loading and packaging.
- Assist the first aid attendant using appropriate precautions against communicable diseases.
- Attach a rope to the stretcher.
- Perform lifting, loading and carrying techniques that avoid back and other injuries.
- Participate as a member of a stretcher evacuation team over terrain which varies from flat to low angle slopes.
- Perform evacuation procedures that do not cause further harm to the subject.
- Be able to use a safety rope to assist stretcher movement on low angle slopes.

Introduction

Many SAR subjects require evacuation – that is, they cannot or should not walk out on their own. Stretcher transportation is often required either alone or in combination with mechanized transport. First Aid courses cover techniques to safely lift and place the subject in a stretcher.

Once in the stretcher, the patient must be secured into it in a manner dependent on the nature of the injuries. A common error is to secure the casualty inadequately, so that he shifts and aggravates injuries when the stretcher is tipped. Tipping may be required to allow for quick drainage of vomitus or when the stretcher is angled up or down a hill. While it is not essential that all SAR group members know the full details of these techniques, it is essential that all personnel be able to assist in a stretcher evacuation. In the discussion that follows, **it shall be assumed that the first aid attendant will be in charge of patient care.**

This chapter outlines the skills and techniques required for wilderness evacuation over rough ground, low angle slopes and short verticals. It is assumed that a **minimum of 6** rescuers is being used. That is, in general, the fewest rescuers with which most obstacles can be handled within the bounds of basic training and the circumstances of most patients.

You must work within the limits of your abilities at all times.

Occasionally, terrain will require you to go to the extremes of these limits. To go beyond, without additional safety gear and the training to use it, as per the specific requirements of PEP, will dangerously risk injury or death to yourself, your team members and to the patient. Unnecessary risk-taking should never be tolerated by any SAR member.

As such, it is strongly recommended that teams with GSAR training not be supplied or supply themselves with any additional technical rescue equipment that would allow them to function beyond these limits, without further training by recognized JIBC instructors. Even then, if trained rescuers have difficulty or any doubt in remembering exact procedures, they should not attempt them.

GSAR team members should be able to evacuate stretchers over rough ground, low angle slopes, and short verticals.

Rough Ground

Rough ground is any irregular terrain offering poor footing that is relatively flat. This could be a trail, field, brush, meadow or swamp.

Low Angle Slopes

A low angle slope is at an angle at which loose material naturally stops rolling. On a low angle slope, an unbelayed fall by a rescuer should not be hazardous, as he will not continue to fall. Some moderately angled slopes such as hard snow, packed mud or slick grass may, due to the consequences of a slip or fall, require rescue techniques ordinarily used in vertical terrain.

Short Verticals

Short verticals are any drop steeper than an embankment up to 30 cm higher than the reach of the tallest rescue team member. The passing of ditches and crevices must also be reasonably assessed regarding the safety of unsecured rescuers operating near the edges of these obstacles.

There will always be grey areas. Safety of rescuers must be the primary consideration, even to the point of becoming an obsession. **Heroics have no place in the SAR team.**

Ground Search Team Leader (GSTL)

The Ground Search Team Leader (GSTL) is the individual assigned to supervise and monitor the conduct and activities of a GSAR team. The GSTL is responsible for the following functions: team safety, performance, accountability, logistics, organizational support, supervision, briefing, reviewing (debriefing), liaising with the SAR Manager or designate, ground to air communications, and record keeping.

Safety Officer

During a complex evacuation, compounded by darkness or bad weather, it becomes impossible for the GSTL to see everything and be everywhere to assure safety. Also, no one is infallible, and the GSTL may miss something or make a poor decision in the heat of the moment. For this reason, the GSTL may appoint a Safety Officer for each operation.

The Safety Officer should be a highly experienced, respected, and conservative individual, whom the team will listen to. If there are enough personnel the Safety Officer should not be used for anything else other than ensuring the safety of the team. He should be allowed to move freely and observe, concentrating on hazards and alerting the GSTL to anything he observes. If, as more commonly happens, his participation is required in stretcher handling, he can still alert the GSTL to any hazards he observes.

This does not mean that other team members can then relax and "leave safety to the Safety Officer". Every member should be constantly aware of his own and other's safety. The effects of an accident caused by a moment of inattention can last a lifetime.

Stretcher Types

Polyethylene Basket Stretcher

These are the most common stretchers used by SAR Groups. They are constructed of a dense polyethylene shell supported by a heavy duty aluminium frame. They can be used on dirt and snow as well as in the high angle environment. Polyethylene basket stretchers come in either one-piece or two-piece models. The two piece models are popular because they can be attached to backpacks when in two pieces.

An example of this type of stretcher is the Ferno-Washington Model 71.

Wire Basket Stretchers

Wire basket stretchers have been used for many years and the two most common are the “Stokes” and the “CMC Rescue Litter”. They are comprised of a rigid metal tubing frame lined with wire mesh.

Fibreglass Basket Stretchers

Fibreglass basket stretchers are constructed of a fibreglass shell supported by a heavy duty aluminium frame. They have been largely replaced by polyethylene models.

Plastic Stretchers

The most common model of plastic stretcher in use is the “Sked” stretcher. It is constructed of a 1 metre by 2 metre sheet which is formed into a cocoon shape. Heavy brass grommets are present on the stretcher for attaching tie-ins, end straps, and carrying handles.

Stretcher Wheels

On most stretcher models, a wheel can be mounted to aid in evacuations. This will help lessen the burden for stretcher carriers, when on long rescue operations.

Backboards

Packaging of the subject often begins with the subject being put onto a backboard prior to a stretcher arriving on the scene. The first aid attendant will determine if a backboard will be used.

Spinal Jackets

Some SAR Groups in BC use soft spinal jackets (KED or SED) instead of a backboard. The advantages of these spinal immobilization devices are their lightweight, ease of use and that they act as an excellent lifting device. If your Group uses one of these devices then your first aid attendant should provide some training to familiarize members of the various uses.

Approaching the Subject

On steep ground, avoid approaching a subject from directly above. Falling rock may be kicked loose by the many feet of the rescue team, and injure the subject. This is a common error of rescuers descending to a car at the bottom of a road embankment.

The same applies when setting up a steadying rope to move a subject up a low angle slope, as the rescuers or the rope itself may knock rocks loose. Set ropes up well to one side, then carry the stretcher to the ropes, rather than setting the ropes up above the stretcher.

You must be especially careful while moving on terrain with loose rocks which could dislodge and fall upon the subject. Ensure that the subject's condition is improved by your intervention and not worsened by it. The injured subject may be lying face up unable to move and protect himself from a barrage of rocks. A helmet on top of his head is not going to protect his face. Fasten plexiglass or wire shields to the stretcher or improvise protection with extra packs or padding. In very loose footing, a wire Stokes litter may be inverted over the carrying litter during exposure, provided that it does not interfere with first aid procedures.

Patient Packaging

The decision to package the patient will be made by the first aid attendant on scene. As a GSAR team member you should be familiar with the packaging equipment your SAR group uses.

The key points to remember when **assisting the first aid attendant** with packaging are:

- Follow the first aid attendant's instructions regarding any first aid or spinal immobilization.
- Have the appropriate equipment available such as blankets, tarps and space blankets.
- SAR team members may hold a tarp above the patient to help keep the patient and equipment dry.
- If there is any chance of rocks falling on the patient try to protect the patient (the building of a barrier with packs/rocks/logs may be required).
- Remove all the patient's wet clothing when you have the equipment ready.
- Place the patient into the dry environment.
- When using a backboard place a Thermarest, insulating pad or blanket between the patient and the backboard to prevent pressure sores and to reduce heat loss.
- Make sure the patient is securely tied to the backboard (if used) and the backboard is securely tied to the stretcher. The first aid attendant will supervise the attachment of the patient to the backboard.
- Maintain easy access to the patient for the first aid attendant to monitor vital signs and to access the injury site.

Improved Blanket and Tarp Packaging

- Place a tarp 2 m X 3 m, out on the ground, in the stretcher or on the backboard.
- Place a reflective space-blanket on the tarp.
- Place a minimum of 2 blankets out on the space blanket.
- Dry the patient making sure that the feet, hands and head are covered. Dry wool socks should be available to be put on both the patient's feet and hands.
- Some teams use heat generation units such as Res-Q-Air or Heatpac Heater to provide supplemental heat to prevent hypothermia in the patient. If your team uses one of these devices you should become familiar with its use.

Precautions Against Communicable Diseases

It is always a possibility that the subject that you are assisting the first aid attendant with may have a communicable disease such as HIV or Hepatitis B. You need to be able to provide assistance in a way that minimizes the risks of infection to yourself.

The main precaution to take is to wear gloves when there is any chance that blood, body fluids or contaminated equipment will be touched. On a SAR operation you should have several pairs of disposable gloves available in case your first pair become damaged.

If artificial respiration or CPR is performed a pocket mask with a one way valve should be used.

PEP recommends that SAR Groups meet with a medical professional to discuss whether a Hepatitis B immunization program should be instituted for the group. If it is decided that an immunization program should be started then PEP will provide Hepatitis B shots to volunteers.

Extended Patient Care

During a SAR operation there is often a period of time after a SAR volunteer has made it to the subject but before the subject can be evacuated. This can vary from minutes to many hours. For example, a team of two SAR volunteers may find the subject and will remain with the subject as equipment and more personnel are moved to their location.

The following is not a complete review of extended patient care but is an introduction to some of the most important considerations. More information can be found in references such as Outdoor Emergency Care (see the resource list at the end of this chapter).

Besides requiring initial first aid the subject will need to have their ordinary day to day requirements met before and during evacuation to medical aid. Their survival requirements are the same as those of the rescuers except that they may need assistance in meeting these requirements. They need:

EVACUATION

- Shelter (both above and below the patient)
- Maintenance of body temperature (dry clothes, fire, etc.)
- Water
- Food (only on very long evacuations)
- Assistance with natural processes such as eating, drinking, urination and defecation
- Psychological support

While the first aid attendant is conducting first aid the other available SAR Volunteers who not directly involved in the first aid can be starting to build shelter for the subject and ensuring that the subject's body temperature will be maintained (having dry clothes available for the patient, getting insulation for above and below the subject, starting a fire, etc).

The rescuers should ensure that they do not put themselves into a hypothermic situation by offering too much of their own clothing and gear to the subject. Having extra subject clothing in a ready pack is essential.

For short evacuations fluids will normally not be given to the injured subject however for long evacuations or where the subject has vomiting, diarrhea, or has extensive burns then fluids should be given. The types of fluids that could be given in frequent small amounts are plain water boullion, fruit drinks or electrolyte containing sports drinks. Food is generally not needed as the subject can go for several days without eating with no permanent damage.

The SAR volunteer must be prepared to assist the injured person with natural body functions such as urinating and defecating. A 0.5 –1.0 L wide-mouth screw top polyethylene bottle can be used as a urinal. It is important to try and prevent the subject's clothing from becoming wet with urine as this can increase the risk of hypothermia. If necessary, a subject can defecate in the supine (on their back) position if a hole is cut through an Ensolite pad or clothes are carefully arranged and positioned over a hole in the ground or snow.

Although medical treatment of injuries must never be compromised, psychological support is very important in maintenance of the subject's will to live. Talking positively to the patient is essential (see page 15 in this chapter) as well as performing your duties in a calm, deliberate and unhurried manner.

The above details are only a few of many necessary to ensure that the subject is evacuated to medical aid in the best physical and mental state possible.

Stretcher Straps

The first aid attendant will supervise the securing of the patient to the backboard or spinal jacket. The backboard (spinal jacket) then has to be firmly attached to the stretcher. For transport over relatively flat terrain the commercially built stretcher straps that come with the stretcher provide the best attachment. They allow easy access to the patient and have wide webbing. One disadvantage is that the locking mechanism can become clogged with dirt or snow. Double-check the clasp once it is secure.

For steep slopes or high angle evacuation, further strapping of the patient to the stretcher is required to prevent lengthways or side to side movement. There are a variety of ways to achieve this with many teams using a combination of webbing and a patient harness.

Attaching a Rope to the Stretcher

When a rope is used to assist the stretcher to go up or down a low angle slope, the rope must be attached to the stretcher in a safe and simple manner. Three examples will be covered in the GSAR Course.

- 1) Use a commercial bridle according to manufacturer's recommendations.
- 2) To attach the rope to a **wire basket stretcher**, a Figure 8 Follow Through Knot is used with the rope wrapped around the basket frame as shown in Figure 14.1. Remember to use a Double Overhand Back-up Knot after the Figure 8 Follow Through Knot.

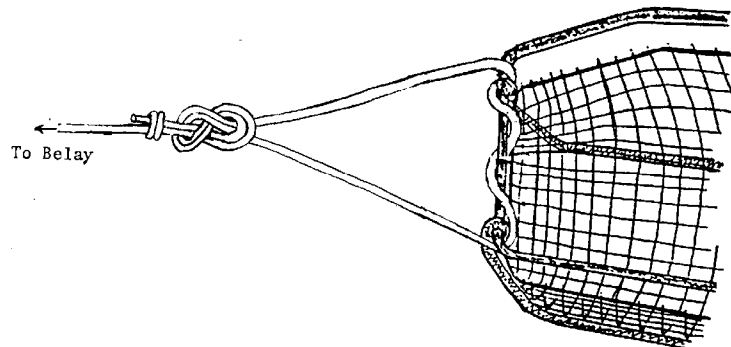

Figure 14.1 Attachment of a Rope to a Wire Basket Stretcher.

Note: For any situation other than a low angle slope a more solid attachment to the stretcher is required.

- 3) To attach the rope to a **polyethylene stretcher**, a locking carabiner can be clipped into the grommet (attachment hole) on each side of the head end of the stretcher with the carabiner gate opening into the stretcher. Separate slings are attached to each locking carabiner and brought up and clipped to a master locking carabiner above the head end of the stretcher. The belay rope is then clipped into the master carabiner using a Figure 8 on a Bight with a Double Overhand Backup Knot.

Guarding Your Back

Back injuries are extremely common among emergency workers. A minor back injury can terribly complicate a rescue, creating a new casualty who must be cared for. Back injuries often recur, to the everlasting pain and incapacity of the victim.

For example, if you are loading someone into a stretcher on the side of a slope, in poor conditions, it is easy to work from an awkward position that you wouldn't consider on level ground. **Always, take your time, get well positioned, and lift with your legs.** During the heat of a rescue, it is easy to ignore body mechanics for just a moment.

GSAR team members should be able to evacuate stretchers over rough ground, low angle slopes, and short verticals.

The most important aspect of correct body mechanics is to "**Bend Your Knees**". The following are other principles of good body mechanics that will help you prevent an accident:

- Use a broad base of support to increase stability – keep feet apart.
- Size up every load before trying to move it. Be sure you are strong enough!
- Ask for help!
- Lift and carry heavy objects close to your body.
- Change sides often when carrying stretchers.
- Roll or slide heavy objects rather than lifting, if possible.
- In snowy conditions it may be better to slide the stretcher rather than carrying it.
- Reduce friction when sliding objects by interposing something smooth. Work with gravity rather than against it.
- Turn from the feet or point the forward foot in the direction of the turn; **Do Not Twist.**
- Align your body in the direction of the move.
- Use your body weight by rocking as a force for pulling or pushing.
- Practice a lift on an uninjured subject before trying an important lift.
- Maintain eye contact with fellow lifters when making a lift, this is the best means of insuring co-ordination.
- Count before lifting. **123 Lift.**
- **Keep Your Back Straight!**
- **Bend your Knees!**

Stretcher Bearing Techniques

Six stretcher bearers is an absolute minimum for any other distance than a transfer to a vehicle. For this number to be adequate, the following conditions should be met:

- The way out (egress) is well known.
- The route is clear of obstacles and the terrain is easily handled (no need for safety lines at any time).

- The patient is light and/or the distance is less than 1 km.
- The patient is stable and not in need of constant supervision by the first aid attendant.

As conditions become more difficult, the team must grow.

- If the "way out" is not known and flagging is required, at least two additional members will be needed.
- If the route is not clear of obstacles, two more members will be needed.
- If the slope requires a belay or steadying rope, then one more member will be required.
- If the patient is heavy and the distance is long, two to four more members would be necessary.
- If the patient requires constant observation or care, one more member is required so that the attendant will have no other job but attend to the patient.

Thus, the numbers can vary from 6 to 16 depending on the specifics of your situation. Figure 14.2 illustrates one configuration for an "ideal" large stretcher team.

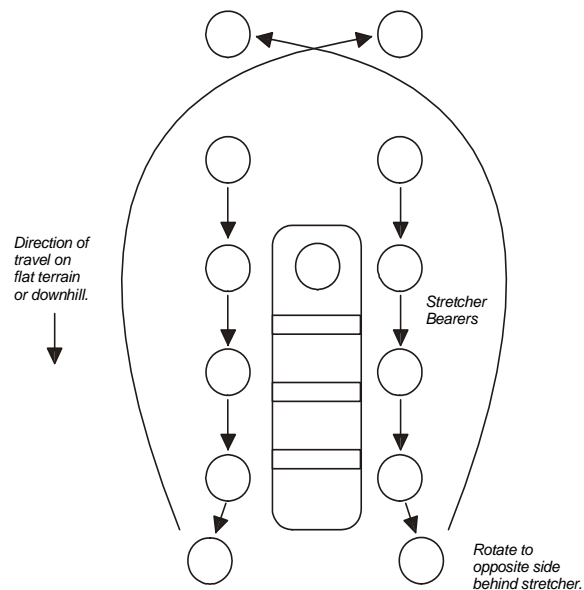

Figure 14.2 Standard Stretcher Bearing Team

Standard Stretcher Bearing Procedures

1. The stretcher is carried whenever possible by six (6) bearers. When starting to move have all the stretcher bearers start with their inside feet. This will give a smoother ride for the patient.
2. In narrow situations, one person at the front end (i.e. the end of the stretcher proceeding first through the narrow passage) and two at the back, unless absolutely impossible. A single rescuer should not carry the back end of a stretcher. The back end position is especially hard as your vision will be obstructed by the stretcher making foot placements difficult and awkward.

3. If any member of the stretcher team slips and falls, the entire team should immediately react by lowering the stretcher quickly to the ground. Do not attempt to compensate for the fallen bearer. The sudden uneven loading can cause the remaining bearers injury. Always keep in mind that your first responsibility is your own safety.
4. Proceed with the stretcher foot end first on flat ground and downhill.
5. Proceed head end uphill.
6. All bearers must rotate on a regular basis. A good system is illustrated above in Figure 14.1. There are a variety of rotation systems: the main criterion is that it works, and allows bearers to rest. On a long haul, the leader must discourage those who insists that they can carry for ten minutes on a side without rest!

Two minutes is a good standard rotation time, with the bearers rotating forward. Each stretcher bearer is carrying for a total of 6 minutes (2 minutes X 3 positions) before getting a rest. This seems short on paper, but it will become apparent in the field that it is quite long enough. Exceptionally strong, uniform teams may go slightly longer.

7. The Ground Search Team Leader will call the rotation. He may or may not stop forward motion during the switch, depending on the situation. When proceeding feet first, the resting members come in from behind to take the head, the two just relieved at the head end move up to the middle position. The middle position bearers move behind the foot end bearers and the foot end bearers let go, step aside and allow the group to pass. Moving head first, the two resting bearers must get ahead of the stretcher in preparation for their rotation. After rotating through the positions on one side of the stretcher, the member will take a rest period before going to the other side of the stretcher for the next rotation.
8. On longer carries and/or in difficult terrain, the number of members ideally should be increased. Still maintain the two minute rotation from heavy to light to rest. Thus with more carriers the rest period is increased but the time on the stretcher remains the same.
9. Pass high obstacles with the stretcher facing head first when going uphill and, if possible, feet first going downhill. Fences and logs no more than 1-2 metres (3-6 feet) high should generally be passed feet first because it is easier to raise the foot end of the stretcher up to the top of the obstruction.

Caterpillar Pass

When obstacles must be passed or footing is insecure, the bearers stop moving their feet and the stretcher is moved hand over hand, until the obstacle or difficult terrain is passed. This is called a caterpillar pass and is a fundamentally important procedure. It should be practised until it becomes second nature. Mastery of this technique allows teams to pass a stretcher with speed, efficiency, ease and smoothness over the most irregular terrain.

As the team approaches the difficult spot, two rescuers who are not carrying the stretcher move ahead to the beginning of the difficult area. They position themselves, facing each other with just enough room between them to pass the stretcher. They ensure a good solid footing and take the front end of the stretcher when it arrives. The two rescuers who were at the front end will now move to the back end. The back two rescuers then rotate around past the four holding the stretcher to get in front at a spot where they can receive the front end. This done, the next two rotate to the front to receive and pass on, etc. A similar technique is used for passing logs, fences and ditches. For a major slope more rescuers are needed. The more people in the rotation the faster the area is passed, the smoother the ride and the easier it is on the entire group.

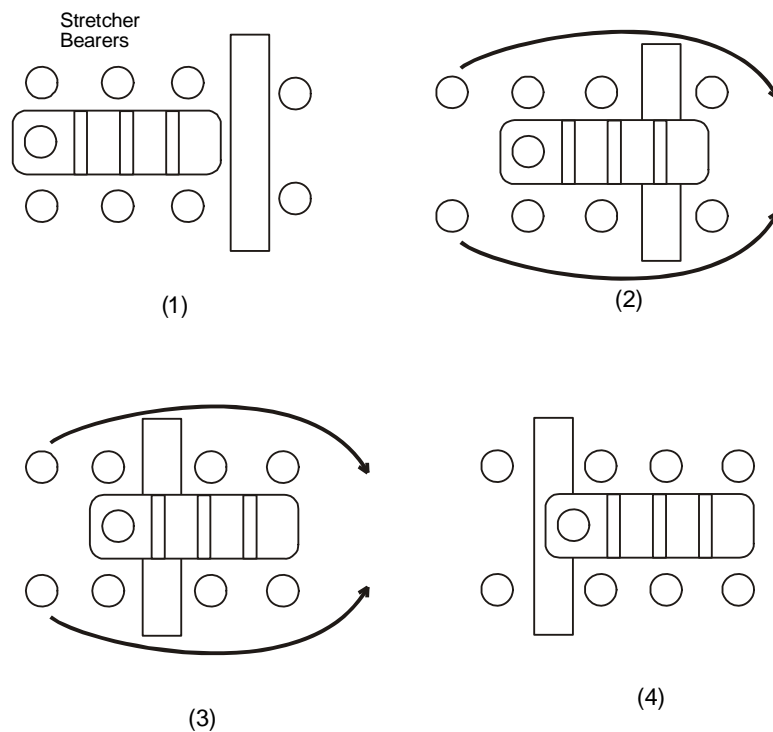

Figure 14.3 Caterpillar Pass

Belay or Steadying Rope

When bearing over continuous rough country a belay or steadying rope is often desirable. For this, two ropes may be attached to the head of the stretcher. As one belayer is belaying, the other is moving ahead, coiling the rope, and walking behind the stretcher until the first rope has almost run out. He then applies a belay and is, ideally, ready to take over when the first belay rope runs out. The first belayer then “leapfrogs” and is prepared to take over when the second rope runs out.

The scouting team should carry webbing and carabiners for constructing anchors. When an area is reached that requires a belay, the scouting team can set up the anchor ahead of the stretcher team. This allows the stretcher team to keep moving once it reaches the rough terrain.

Further information about belaying a stretcher team on low angle slopes is included in the chapter “Orientation to Rope Management”.

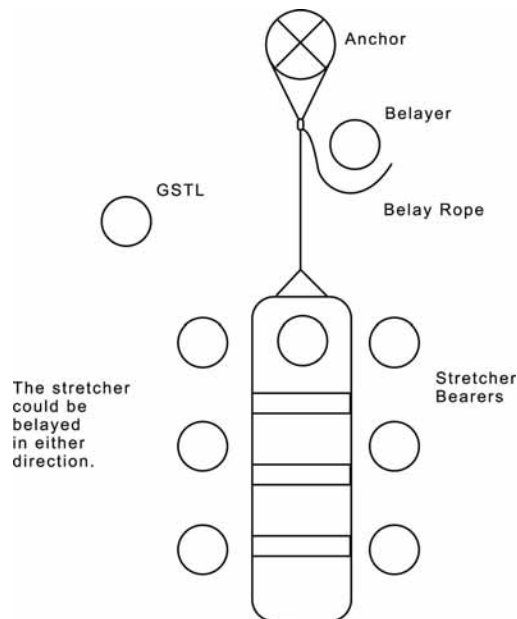

Figure 14.4 Belaying a Stretcher

Falling rocks

All members must beware of moving, loose rocks on steep ground.

Falling rocks are one of the greatest hazards in rescue operations. This is one of the reasons helmets are so important. Whenever a rock starts to fall whoever sees it should shout “**ROCK!**” to alert those below. Despite our instincts to observe the falling rock’s trajectory you should not look up. Face straight ahead, hunch your shoulders, attempt to move into a sheltered position and wait for the rock to clear.

Talking to the Subject

After being evacuated many subjects state that the evacuation went smoothly but that they felt ignored. The rescuers talked among themselves but no one talked to the subject. It is important not to forget about the person who you are evacuating.

Make them aware of what is going on around them but do not emphasize any of the problems that will inevitably occur during the evacuation. Being confident in the skills of your team will make them feel safe and secure.

Additional Reading

Bowman, W.D., *Outdoor Emergency Care*. Second Edition. National Ski Patrol System, Inc, 1993.

Foster, Richard. *Patient Packaging for Wilderness Search and Rescue*. From the GSTL manual.

Provincial Emergency Program, Justice Institute of BC, Emergency Management Division. *Ground Search Team Leader (GSTL) Manual*. 1997

Further references listed in the Bibliography.

Chapter Review

Please answer the following questions on a separate sheet of paper so that another student can use this manual. The answers to these questions are located at the end of the manual.

1. What is the most important procedure for protecting your back?
2. Who decides whether a backboard will be used?
3. What do you have to consider when approaching a subject down a low angle slope.
4. Why would you want a Safety Officer in addition to a Ground Search Team Leader?
5. When is a "Caterpillar Pass" used?

Answer **True** or **False** to the following statements.

6. When travelling downhill the head end of the stretcher goes first.
7. A common error is for the patient to be inadequately secured to the stretcher.
8. When you hear "**Rock**" it is best to look to see where the rock is coming from so that you can avoid it.
9. The straps that come with stretchers should never be used.
10. Maintaining eye contact with your fellow lifters is a good way to ensure co-ordination.





Chapter 15 - Type 1 Search Methods – Initial Response Searches

Upon completion of this chapter, you will be able to:

- Define Initial Response Searches (Type I methods) and justify why they are the most effective and efficient methods to use at the beginning of most searches.
- Describe confinement tactics.
- Describe attraction techniques.
- Describe the use of search dogs in SAR.
- Describe the role of mechanized equipment in initial search techniques.
- Describe the roles and responsibilities of IRT members.
- Perform as a member of an Initial Response Team (IRT).
- Explain the problems associated with searching at night.
- Explain the distinct advantages of searching at night.

Introduction

In the early stages of a search the potential search area is quite large relative to the number of trained SAR personnel available. Initial response searches require a rapid deployment to areas of highest probability. Tactics and techniques include:

- Investigation
- Initial Interviews
- Tracking
- Search Area Reduction/Perimeter Sign Cuts
- Confinement
- Attraction
- Search Dogs
- Quick Reconnaissance
- Aerial Reconnaissance

These procedures are classified as Initial Response Searches (formerly Hasty Searches or Type I search methods) and are described in greater detail in the sections that follow.

Initial Investigation

It is seldom that a new GSAR member will be involved in the initial investigation. Usually the Duty SAR Manager will gather this information and use it to decide on the search urgency and define the search area. Information gathering was discussed in the Search Initiation chapter.

Search Area Reduction/Perimeter Sign Cutting

If experienced trackers are available they may be used to check the last known position (LKP) for tracks, clue, direction of travel, etc. They may sign cut a perimeter around the LKP and determine if the subject has left the search area. If the subject has left an area there is no point searching it.

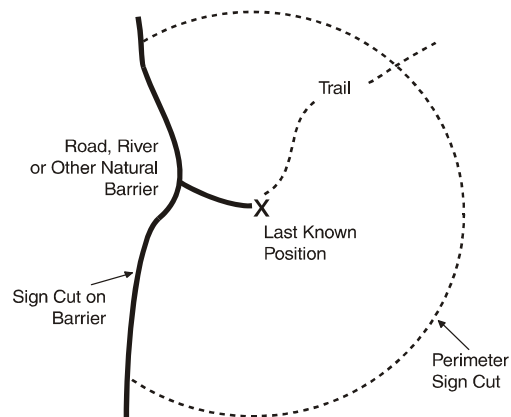

Figure 15.1 Sign Cutting

They will look for any indication that will establish with greater certainty the direction the subject is heading from the last known position.

If a direction of travel can be established, then an area having a high probability of the subject being located in is defined.

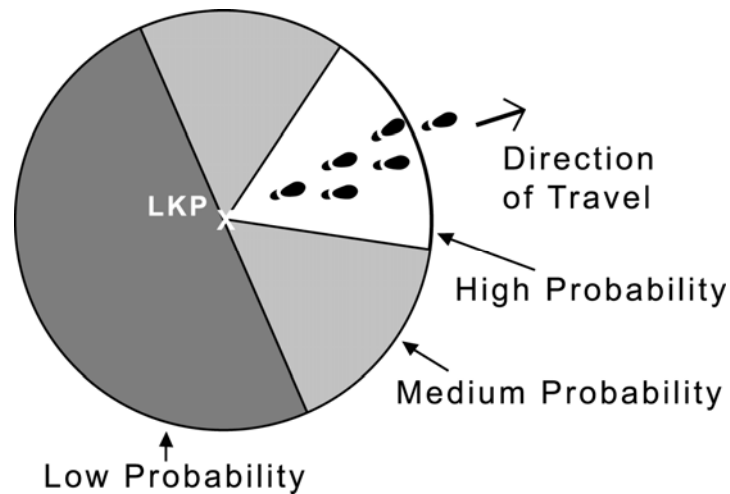

Figure 15.2 High Probability Search Area Defined by the Subject's Direction of Travel.

Tracking

Once a direction of travel has been established, tracking may also be used to follow the known or suspected route. Two groups of trackers may use a technique called cutting sign to move more quickly along the subject's route.

The skills required for tracking and for the related procedure, sign cutting, are beyond the GSAR Course.

However, searchers without training in tracking still need to know what these skills are and how to assist trackers using them. An overview of tracking is given in the Orientation to Tracking chapter.

Confinement

The search area increases as the missing person travels. If the mobile missing person is found quickly, the possible search area rapidly increases. Confinement procedures ensure that the subject cannot leave the area without the searchers being aware of the departure.

Confinement should be used as soon as possible in any search.

Although most missing persons are located within a relatively small distance of the LKP some individuals travel a surprising long distance. Regardless of the urgency of the search, it is desirable to introduce confinement procedures immediately. Confinement techniques include:

- Road blocks
- Trail blocks
- Lookouts
- Camp-ins
- Track traps
- String lines

Some of these procedures can be boring for the SAR volunteer but being thorough with these assignments is critical for the success of the search.

Road Blocks

If the subject wanders out onto a road, he may find a ride out of the area with neither the motorist nor himself realizing that a search is in progress. If his safe departure does not become known, the search could conceivably continue for days. Road blocks at appropriate locations will reduce this possibility. Figure 15.3 illustrates a typical arrangement. Even on foot, travel on a graded road can be quite rapid (up to 7 km per hour), so even if the victim does not get a ride, interception is very important. Road blocks also provide an opportunity to alert non-search personnel who are going into the area to be on the lookout for the subject. Their co-operation could contribute to the success of the search. In addition, people leaving the search area can be questioned on whether they have seen the subject.

Searchers who are stationed at road blocks should be well identified with uniforms if they will be stopping vehicles. These searchers need to possess good interviewing skills and be in radio contact with the base.

Trail Blocks

Often the lost person finds a trail but doesn't know which way to go. One direction may lead back to the car, the other into the wilderness. By blocking the wilderness route, the lost person will be prevented from going too far in the wrong direction. "Trails" include any good travel aids such as creekbeds, powerlines, seismic lines and beaches.

A team of two or three is all that is needed. At least one person should remain awake and in a position to see the trail at all times. It should not be assumed that the lost person will stop just because a camp is seen. He may believe that he is on the trail out and that his car is just around the next bend in the trail. Figure 15.3 illustrates a trail block. A position should be taken where a person can be seen approaching for some distance. For various reasons, including the sheer embarrassment of being lost, the missing person may not want to be seen, so it is important that the searcher be able to see the approaching person first.

The trail block team should have a radio and the ability to communicate with base as well as having copies of the Missing Person Questionnaire.

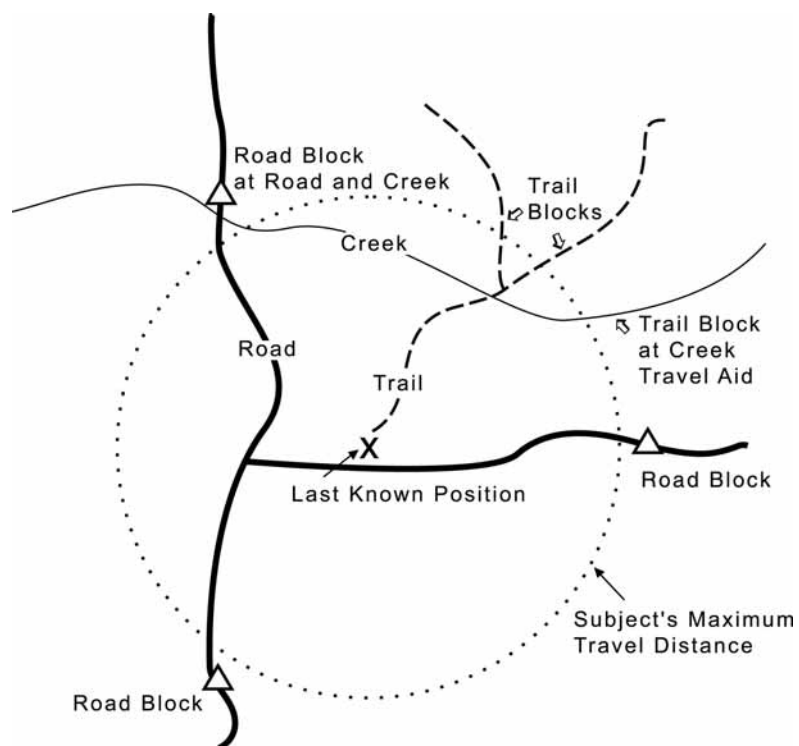

Figure 15.3 Road and Trail Block

Look-Outs

In open areas, such as above treeline or in the sub-alpine it is possible for searchers to take a position on a hill or ridge affording a view of several potential travel routes. If the lost person comes along the travel route, the lookout will see him. Figure 15.4 illustrates a lookout situation.

A lookout should work with a partner. The lookout can direct the partner by radio towards suspicious objects that may be seen in the valley through binoculars. It is important to have lookouts at night as well as in the daytime. The sounds of the victim will usually be much more audible after dark and the light of a candle or flashlight will only be visible under these circumstances.

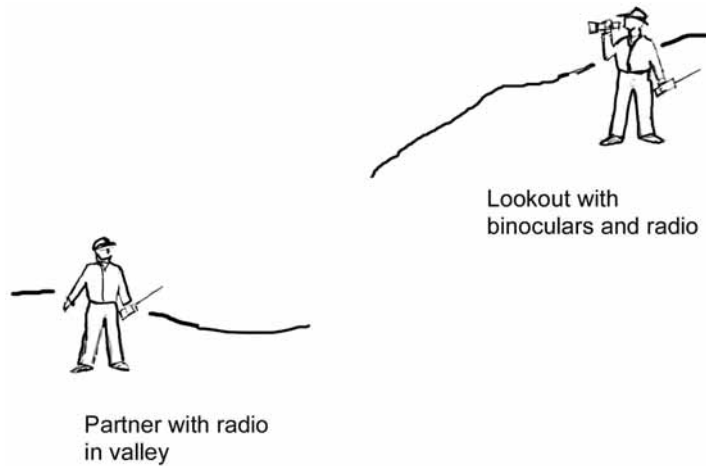

Figure 15.4: Lookout

Camp-In

A camp-in may be a trail block, a lookout, a radio relay or virtually any situation where searchers are stationed on a full-time basis. For confinement purposes a camp-in would be located in the periphery of the search area. It could be stationed anywhere for detection purposes. Natural features where a lost person may be attracted, such as a pass between large hills, are ideal spots for a camp-in.

Track Traps

Track traps are areas where footprints are easily seen. Naturally occurring track traps include creek banks, beaches, road shoulders, dusty or muddy trails and snow patches. These are checked as part of the search.

A man-made track trap can be constructed where the terrain narrows or otherwise constricts passage and can thereby function as an unmanned camp-in. If soft soil is smoothed and then re-checked periodically, the presence of tracks becomes a very helpful clue. A number of track traps may be used and each one should be checked relatively frequently. This can be an effective technique if there is a shortage of personnel.

Tagged String Lines

Where dense brush and trees prohibit the effective use of lookouts string lines can be used to create an artificial boundary. String lines can be placed using a “hip-chain” device that lays out string while recording distance travelled. Tags indicating to the missing person which way to go to safety should be hung from the string lines at regular intervals. This technique has not been used very frequently in BC. Figure 15.5 illustrates the string line confinement technique.

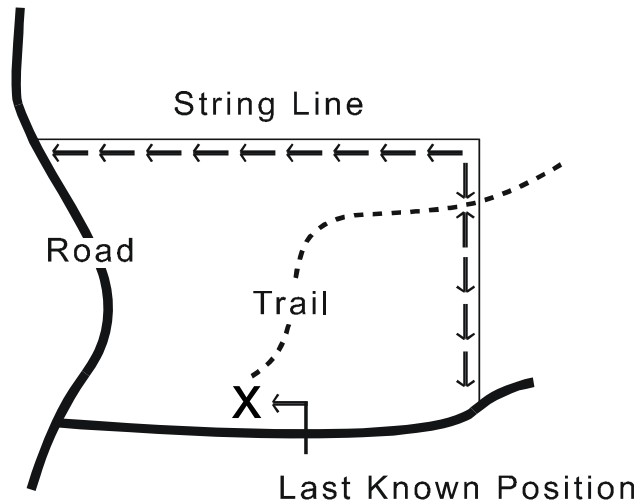

Figure 15.5 Tagged String Lines

Combinations

A number of these methods may be used in combination in order to achieve confinement. For example, trail blocks can construct trap tracks on nearby travel routes or could function as lookouts in mountainous terrain. The choice will be dictated by terrain, available personnel and area size considerations.

Searchers positioned at confinement sites can also use the attraction techniques, which are listed below.

Attraction

In order to assist a mobile or responsive subject, various techniques can be used to enable the subject either to make their own way to safety or to make their presence known to the search team.

Attraction techniques include the use of sound and visual signals.

Attraction techniques should not be used around dangerous terrain (especially at night) as this may draw the subject into a more dangerous spot. Care should be used while using sound attraction techniques to protect your hearing and the hearing of your team members.

Some procedures that may be used to attract the missing person include:

- Calling
- Sound
- Beacons

Calling

The missing person's name may be called out at frequent intervals at all stages of a search and especially should be used by confinement and initial response teams. Several people yelling the name simultaneously is most effective. Silence should then be kept for at least 10 seconds in the hope of hearing a response. **Careful co-ordination of this technique is essential.** Of particular concern are circumstances arising from the presence of more than one team in the same area where the technique is being used. In good weather assume that the subject will remain responsive for 72 hours but the response will be weaker as time goes by.

Sound

Sirens, horns, whistles, chainsaws or any other loud sound sources may be sounded at regular intervals to attract the missing person. If the sound source is from a vehicle, the vehicle be stopped and the motor should be off so that responses can be heard. Establishing the direction from which a sound comes may not be easy for the subject so a visual signal should also be given. Some possibilities include flares, spot lights pointed at the sky at night and balloons above the forest canopy. Consideration of the subject profile is important when deciding whether or not to sound a siren. This noise could frighten some subjects such as children or the mentally challenged and have the opposite effect to what was intended.

Loud Sound Attraction and Response

In many less settled areas of BC many missing persons will be carrying firearms (eg hunters, trappers, prospectors). Gunshots can be heard for many kilometers and can be used to locate a responsive subject. Recently, in Fort Nelson, a lost hunter was located after a number of days when searchers heard his gunshot.

Instead of using live ammunition, devices such as bear bangers or bird bombs can be used. However, care has to be taken to avoid starting fires in dry forests with these devices.

If live ammunition is used the searcher has to be properly trained in firearms and has to consider where his gun is pointed at all times and never use it near settled areas. Using a shotgun with birdshot lessens the concern about where the bullet will land.

Before using this technique, the loud sound source has to be calibrated for the conditions of the day. A searcher moves in one direction and every 250 m fires a shot (or whatever loud sound is being used) until he is no longer heard. Since wind will reduce the distance that the signal and response can be heard, the calibration should be repeated upwind and downwind.

Once calibrated the searchers can move along the search route using the following procedure:

- Move the distance along the search route that the sound can be heard (for example you calibrated your bear banger and found that the sound can be heard for 1.5 km).
- Stop the engine, fire two shots at least 10 second apart. Have ear protection available to put on while firing the shots to preserve your hearing.
- Take your ear protection off and listen carefully for a response for one minute.
- Listen for several more minutes while scanning the search area with binoculars.
- Check with other teams by radio to see if they heard a response that you may have missed.
- Move to the next signal point (another 1.5 km)

If you get a response, try to get a compass bearing on the response (it may be difficult). Mark the bearing on the map and move to another spot and fire again. Take another bearing and triangulate the subject's position on the map. If other teams are in the area and can hear the signal, they can take the second bearing (see page 7-9). The location may not be totally accurate but it will help you move towards the subject's location.

Beacons

Beacons are especially useful at night when a bright lantern or the light of a fire can point the lost person to safety. The smoke from a fire, reflectors, or signal panels can all perform the same function during the day.

Search Dogs

As the subject moves through an area a scent is left behind and Police and civilian SAR dogs are commonly used to follow this scent. The type of dog that is used in most searches in BC is one that is trained to follow any human scent. Dogs can discriminate between the scent of different people but the situation where a dog is given an article of the missing person's clothing to smell and then told to look for that scent almost never happens here. Thus, the scent of searchers can easily be a distraction to a police search dog.

In areas where the police have dogs trained for searching, their use, particularly in the early stages of a search, is very likely. To be effective, they must be searching areas through which searchers have not passed. Thus, where this early use of dogs is anticipated, all high probability areas must be kept free of searchers until the dog has finished with these areas. Decisions regarding such areas are a police / search management responsibility.

A further situation that can limit the effectiveness of search dogs is the presence of other dogs. Untrained and unsupervised dogs have no place on a search. **Leave your pet at home.** Bystander's dogs also have to be kept away from the search area.

All dogs used on the search fall under the jurisdiction of the RCMP Dog Master. Anyone who is training their dog for use in SAR has to be working through an RCMP Dog Master.

Police search dogs are most effective in humid conditions and light winds. They work downwind from the area to be searched and can function effectively day or night. Having dog handlers that are good visual trackers is a valuable asset as the handler may be able to follow visible sign after the scent is no longer detectable by the dog.

Quick Reconnaissance

Quick reconnaissance is the searching of high probability areas such as trails and hazardous areas by small teams. Statistics show that at least 50% of missing persons are found on some form of travel-aid, therefore a search of roads, trails, ridges and drainages is a very efficient way to initiate a search.

Mechanized Search Vehicles

In some cases, mechanization can increase the speed of these searches. Searching a network of logging roads is best done by 4 wheel drives, ATV's, mountain bikes, snowmobiles or horses. An organized SAR group with a pre-plan and an up-to-date listing of resources will know how to access them. However, it must be stressed, that seeing tracks from moving vehicles is not easy and not particularly effective.

Depending on the nature of the trails, it may be possible to use either trail bikes or horse-mounted searchers, although horses should not be used where a search dog is likely to operate. In winter conditions, snowmobiles can be of great benefit.

Two points should be remembered in using such assistance. The first is that engines of motorized transport should be stopped at frequent intervals in order to call for the missing person and listen for a response. The second is that **clues must not be destroyed!** Tires, snowmobile tracks, horses hooves are all great destroyers of sign. In high probability areas it is best if trained sign-cutters are sent in before motorized equipment or at the very least the searchers on the equipment should be sign aware.

Initial Response Teams

Machines may occasionally be advantageous, the majority of initial response searches must be done by foot.

Initial Response Teams are fit, fast and skilled teams that quickly search the high probability areas. Many small communities may not have a SAR group but they have an Initial Response Team (IRT). These teams have to have all the skills of an IRT that is mobilized by a SAR Group as they will provide an initial response until mutual aid can be brought in.

An Initial Response Team (IRT) mobilized by a SAR Group will typically consist of three people.

Familiarity with the area is a strong asset for a member of such a team, and inclusion of a volunteer from outside the SAR group who knows the search area very well could be of great benefit.

All members of the IRT need to be:

- fit and fast,
- have very good survival skills,
- be trained in aspects of SAR Management, interviewing, scene protection, record keeping,
- be very clue conscious and
- have a higher level of first aid.

At least one member of the team must be skilled in navigation, as details of the route followed must be given to the SAR Manager. Most teams will be equipped with a radio, so radio communication skills are also a must. If possible, have a trained tracker on each IRT. All trails in the search area should be investigated by IRTs, and well defined trails may be searched at night.

Cabins and known camping areas should be checked. Areas where cliffs and other hazards exist should be investigated to the extent it can be done safely. Watercourses should be followed to at least the perimeter of the search area and possibly further if travel proves to be easy. Other probable routes such as ridges and spurs leading onto ridges may warrant investigation if there are sufficient numbers of trained personnel.

The attachment of flagging tape (preferably biodegradable) at regular intervals along the route taken is common practice. Using flagging tape unique to SAR is recommended. This flagging tape can be of benefit in helping the search team retrace their steps and it tells other searchers that the route has already been followed. A marking or ballpoint pen may be used on the flagging tape to provide information to other search teams. Such information may include Team number, date, time started, and compass bearing. (eg. IRT #1 30 Nov 97 1430 Hrs 090° MAG which translates to "Initial Response Team #1 on the 30 of Nov, 1997 at 1430 hours heading on a compass bearing of 090° Grid").

Night Searching

Flagging tape should not be used indiscriminately. If there is no necessity for it to serve either of these purposes it should not be used. Plastic flagging tape will remain where it has been placed for many years unless it is removed after the search. Desecrating wilderness areas in this way should obviously be avoided.

Searching at night can be quite difficult, but very effective and may be necessary when the victim profile and weather conditions demand a full and immediate response. Even in cases where a full response is not required, the immediate application of confinement techniques is certainly beneficial. Thus, some degree of activity is appropriate for almost any search that starts or continues through the night.

Effective searching includes searching at night.

Although more complicated search patterns may be impractical to conduct at night, initial response teams can operate in the dark and most types of confinement procedure can also be applied at night. The IRT's searching will be slower due to limited visibility and difficulties with navigation. Co-ordination of teams at night will be more difficult.

However, there are distinct advantages to searching at night and include the following:

- The subject is usually stationary and more aware of sound.
- The amount of time during which the search is conducted is increased.
- Sounds and smells are easier to detect.
- Light from beacon fires and flashlights will be more visible.
- The absence of ambient noise from daytime activities makes sound sweeps more effective.
- Tracks illuminated at a low angle by a flashlight show up more readily than when illuminated by the overhead sun.
- Radio communication is usually clearer at night.

Some form of light is required for a night time search. Hand-held flashlights are satisfactory, but headlamps, allowing for hands-free operation, are the most effective. All searchers must be equipped with a light with good batteries and carry extra batteries and light bulbs. It is important that searchers do not allow their lights to shine in other searchers eyes as each time this occurs it takes several minutes to restore the searcher's night vision.

Another concern about searching at night is the danger it can represent to the searcher. Areas that cannot be searched safely should be left until daybreak. Cliff areas and areas where old mine shafts exist are places to avoid at night.

Summary

The majority of missing persons are found solely by the application of Initial Response methods. Such searches are usually of short duration and generate little media attention. It is those few occasions when these methods are not successful in locating the missing person that the highly publicized large scale searches take place. When this situation happens, what are referred to as Sweep Searches and eventually Grid Searches are used. These will be discussed in the following chapters.

Additional Reading

Provincial Emergency Program, Justice Institute of BC, Emergency Management Division. *Search and Rescue Management*. 1989.

Further references listed in the Bibliography.

Chapter Review

Please answer the following questions on a separate sheet of paper so that another student can use this manual. The answers to these questions are located at the end of the manual.

1. What is meant by an initial response search?
2. Describe two attraction techniques.
3. Explain why searching at night is recommended.
4. Why do you have to be careful when conducting searches by motorized vehicles?
5. What skills are required for an IRT team?
6. What is the advantage of determining the direction of travel?

Answer **True** or **False** to the following statements:

7. A track trap can function as an unmanned camp-in.
8. At least 50% of missing persons are found on travel aids.
9. Tagged string lines are used frequently in BC.
10. Searchers conducting confinement procedures should not use attraction techniques because they will confuse other search teams.
11. Confinement is only useful immediately after the person goes missing.

Chapter 16 - Type II Search Methods – Sweep Searches

Upon completion of this chapter, you will be able to:

- Define a sweep search.
- Describe different types of sweep searches.
- Demonstrate a sound sweep.
- Demonstrate a visual sweep.
- Participate as a member of a 3-person team in a sweep search and be able to serve as either a compass bearer or a flanker in such a team.
- Define Critical Separation.
- Outline other varieties of type II searches such as:
 - Use of feature guides
 - Contour searches
 - Aircraft
 - FLIR
 - Dog searching

Introduction

The Initial Response Search methods previously described are usually the most effective way to initiate a search. A more thorough examination of the search area requires a large number of trained personnel and such resources are not likely to exist early in a search. However, when a number of searchers are available and some reasonably high probability areas exist, it is possible to initiate a sweep search of these areas using widely spaced searchers. Closely spaced searchers conducting “Closed Grid Searches” are highly inefficient and should only be used in very specific situations. They will be discussed in the chapter “Closed Grid Search”.

Martin Colwell of Lions Bay SAR has done considerable work on probabilities of detection (POD). His research has become the foundation to BC’s sweep configurations. Five types of sweep searches can be used and include the following:

- Sound Sweeps: for adults or children who are probably still responsive to sound.
- Standard (Visibility) Sweeps: for adults or children wearing normal outdoor clothing or adults or children who, under winter conditions are likely to shelter beside a tree within sub-alpine forest.
- High Visibility Sweeps: for adults wearing high visibility clothing or adults or children who, under winter conditions, are likely to move into open areas within sub-alpine forest.
- Low Visibility Sweeps: for unconscious persons or persons wearing low visibility, camouflaging colors or infants or toddlers in dense coniferous forest
- Body Sweeps: Persons presumed to be dead.

It should be noted that Colwell’s POD data is for coastal terrain and there is some uncertainty as to the extent to which the POD calculations have to be modified for use in other terrain types.

The SAR Manager will select the type of sweep that will be conducted based on the subject category, the terrain type, and the personnel and equipment available.

Sound Sweep

If the subject is responsive, the sound sweep is the most effective sweep search method. Sound sweeps utilize sound attraction in combination with wide searcher spacing to cover large search areas. The sound sweep search is 3 to 4 times more effective than visual sweeps and is a practical night searching technique.

A sound sweep should be implemented immediately if the initial response searches have been unsuccessful. It should be initiated within the first two days of a search (preferably within 24-48 hrs) when the subject is likely able to respond (usually by shouting).

SWEEP SEARCH

Sound sweeps are not conducted in the same way as the sound attraction used in an initial response search. In the initial response search there is minimal co-ordination of sound production. In a sound sweep, radios are used to co-ordinate the sound production used to attract the subject.

To conduct a sound sweep, all members must have a whistle, radio and compass. A base station is set up which will co-ordinate the whistle-blasts. The searchers move to their points on the baseline, mark the starting location, and either follow a compass bearing or a direction (i.e. uphill, downhill). Searchers do not have to start at the same time from the baseline. The first searcher to reach his starting spot will radio base and the timing of the whistle blasts will commence.

Searcher spacing varies depending on the desired probability of detection (POD) and the search conditions (i.e. dense coniferous forest under summer conditions). Colwell has produced probability of detection tables for certain terrain types that SAR Managers can use. Searcher spacings of 43 m to 200 m are common. At these spacings searchers will not be able to see each other.

The base radio co-ordinates the searchers to produce one whistle blast every one to two minutes depending on the search conditions. To coordinate each blast, the base radio will say "4,3,2,1, BLAST". The searchers cover their ears, blow their whistles, then uncover their ears and listen for 5 seconds for a response. Covering the ears during the whistle blast prevents the searcher from losing their hearing sensitivity.

Also, do not move as you listen for a response as the noise of moving fabric (e.g. Gortex) will drown out any faint sounds.

The searcher then continues on his route until the base radio calls for another whistle-blast. This is repeated until the search area has been covered.

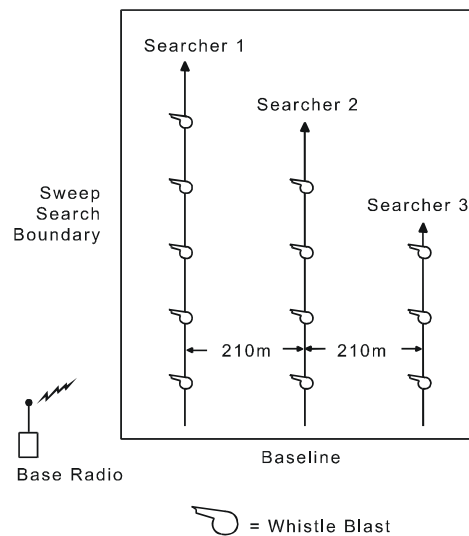

Figure 16.1 Sound Sweep

Sometimes an area will be searched to 40% POD using the sound sweep technique. In the beginning of the search it is sometime better to search large areas at lower PODs than small areas at high PODs. If enough personnel is available, additional sound sweeps may be performed at right angles to the original sweep to increase the probability of detection.

Other Sound Sweeps

The sound sweep technique can be adapted for other situations such as trails, trailheads and roads.

Trail Sound Sweeps

Search teams that are travelling on trails can be co-ordinated by the base radio to produce whistle blasts in much the same way as the searchers travelling on compass bearings. The use of a whistle blast increases the probability of detection on the sides of the trail well beyond the limits of visibility. Only one radio per team is required when the trails are searched by teams of three. The recommended length of time between whistle blasts is 30 seconds for trails located in dense coniferous forest and 1 minute for trails located in open Sub-Alpine Forest. Although the whistle blasts are very frequent, lengthening the time between blasts will lower the probability of detection.

Vehicles at the trailhead can also be co-ordinated with the searching field teams to perform horn-blasts at the same time.

Vehicle Sound Sweeps

Vehicles equipped with radios may also be used to perform sound sweeps. The convoy of vehicles are stopped 1 km apart and simultaneously sound their horns. The drivers listen for a response then drive 0.1 km up the road and stop and wait for the next signal to sound their horns. Once the horns have been sounded and the driver has listened for a response, the vehicle is moved up another 0.1 km. This continues until each car has driven 1 km at which time the convoy moves up to a new section of road and starts the process again.

Visual Sweeps

Visual sweeps depend on the eyes of the searcher to find clues, sign or the subject. Visual sweeps should be used only if it is suspected that the subject would not respond to sound, the search area is small and there is enough person power available.

It should be remembered that visual sweeps are considerably slower than sound sweeps. They require more person power than a sound sweep to cover the same amount of ground in the same amount of time. Searchers should still call or use whistles at frequent intervals while conducting a visual search.

Conducting a Sweep (Open Grid) Search

The procedures for conducting a visual sweep or a sound sweep are relatively similar. It is recommended that a sweep search be conducted as outlined by Colwell.

1. The SAR Management Team will divide the search area into relatively small segments. As most teams are made up of three members, each team's search segment width will often be 3 times the distance between the searchers. If time and personnel permits, baselines, search segment boundaries and searchers starting locations should be flagged with tape or string.
2. For a sound sweep each searcher should have a map, compass, a whistle and a radio. For a visual sweep each searcher should have a map, a compass and a whistle. If the searchers can still see each other, each 3-man team should have a radio. If the searchers cannot see each other each searcher should preferably have a radio.
3. The searchers are divided into 3-person teams and given a search segment to search. Each searcher is given a defined starting location along the baseline of their search area. The searcher spacing is based on:
 - Desired thoroughness of search (desired probability of detection)
 - Type of Sweep (eg. sound versus high visibility)
 - Search conditions (alpine, sub-alpine, timber, season)
 - Total surface area to be searched
 - Time available for searching area
 - Number of personnel available

This information can be used to look up correct searcher spacing in Colwell's POD tables. If the search terrain type is not described in the POD tables then critical separation may be used to set searcher spacing. Critical separation is discussed later in this chapter.

If the baseline is not flagged, the searchers may pace themselves to their starting locations. Determining your own pacing distance is described in the chapter "Map and Compass". Note: everyone has a different pace depending on the length of their stride.

4. Searchers are dispatched in teams of three from their respective baseline positions. It is preferable to stagger starting times of each team, as it is easier to co-ordinate and wastes less searching time than attempting to handle large numbers of searchers at once.

5. Searchers then sweep the search segment following the compass bearing (datum line) that they have been assigned. Stopping, calling, whistling and then listening, looking forwards, backwards, upwards and side-to-side as well as purposeful meandering have all been found to increase the probability of finding the missing person. Do not hurry. Look for small clues as well as for the missing person. If a sound sweep is being conducted, each searcher will be prompted by radio to perform a whistle blast, on cue, typically every one to two minutes. After performing each whistle blast, stop and listen for the missing person's response before continuing the sweep.
6. When a team has completed a sweep, the exit location should be flagged and labelled by that team. The team should communicate with base to record their exit time, provide brief details of their sweep and determine if they are required to proceed to a new search area.

Visual searches may be carried out at spacings at which searchers cannot see each other. If this is the case every searcher needs to have a compass, map, whistle and preferably a radio. It is necessary to be proficient at navigation. It does not help the search if a search area is missed because of a navigational error or a searcher gets lost.

Visual searches may also be carried out at spacings at which searchers can see each other most of the time. Distances are usually 10 to 30 metres in length.

If the searchers can see each other most of the time, the three-member team will consist of a compass bearer and two flankers. The point where the compass bearer starts the sweep should be clearly marked. The flankers use the compass bearer as a guide for maintaining their spacing, but may move to either side in order to check out locations in which the victim could be hidden, as well as to get around impassable objects.

The flankers should also flag the outside of their search area to guide the next search team. Even though flagging slows down the search team, it prevents adjacent teams from overlapping (causing inefficient searching) or having gaps of unsearched areas between the teams.

The typical arrangement of a 3-person team is illustrated in Figure 16.2.

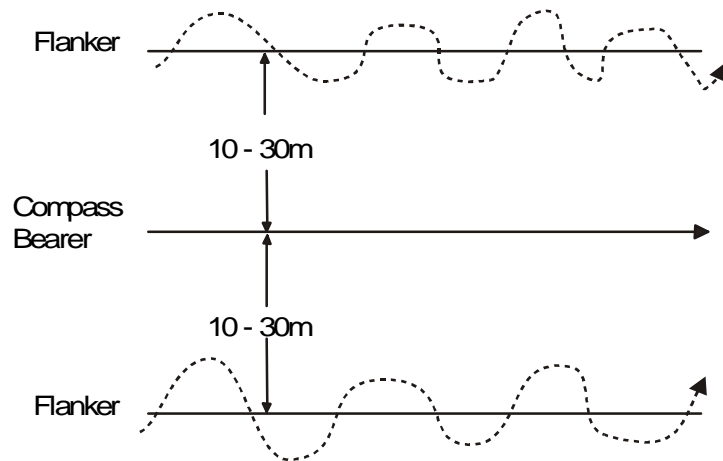

Figure 16.2 3 Person Sweep Team

Critical Separation

Another technique that is used for setting distances between searchers is critical separation. This technique requires closer searcher spacings than Colwell's Visual Sweep and therefore requires more personnel to cover the same area. However, it is a technique that is readily adaptable to all terrain types.

This technique may be used if Colwell's visual sweep search tables do not include the type of terrain that is to be searched. Critical separation is the searcher spacing that provides a high probability of detection (50 – 80%) regardless of terrain type.

Two searchers are required to determine critical separation. A pack of approximately the same colour as the missing person's clothes is placed in the area to be searched. The two searchers walk away from the pack in opposite directions until each searcher can just see the pack. The critical separation is the distance measured between the two searchers. It is twice the limit of visibility of the object between the searchers. The exercise is repeated in a different spot and the average critical separation is calculated.

This distance is used to set up the visual sweeps of the search area. At this separation most objects between the two searchers should be seen although there is a chance that something will be missed.

Note that Critical Separation is not the distance from either searcher to the pack but twice the distance. For example, if each searcher walked 10 m from the pack before losing sight of it the critical separation is 20 metres.

Do not estimate critical separation in the woods next to the road as the vegetation is often thicker where the light from the road opening penetrates.

Feature Guide

The advantages of this technique are that critical separation can be determined in the field for any particular conditions or vegetation and that approximate PODs can be determined.

Rather than follow a particular compass bearing, searchers can use a road, a trail or a well-defined drainage as a guide. The searcher closest to the feature uses it as a guide and the other searchers in the line use the inner searcher as a guide.

This type of search proceeds quickly as a compass bearing does not have to be followed. The searcher travelling along the feature should be diligent in searching for sign or clues as often the subject has used the feature as a travel aid. The farthest searcher from the feature flags or strings a line for the next pass of searchers to follow.

On some features, such as large rivers that act as barriers, only one side of the feature will be searched. On other features, such as roads, both sides of the feature will be searched. Teams working on opposite sides of a feature will work independently of each other.

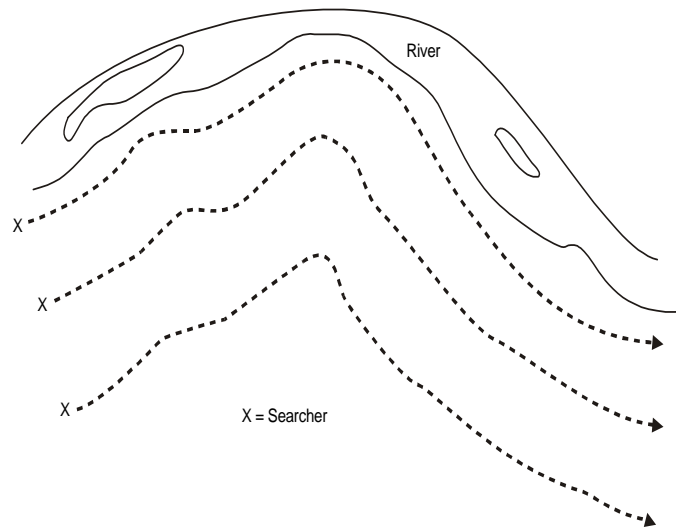

Figure 16.3 Searches Using a Feature as a Guide

Contour Search

Another variation involves the use of an altimeter by the compass bearer (navigator). Instead of maintaining a constant direction, the navigator attempts to follow a path of constant elevation with the flankers maintaining their spacings on either side of the navigator.

Contour searches work particularly well when the assignment is a large mountain slope where a lateral search is preferred over a top-down or bottom-up search.

Remember, an altimeter registers differences in air pressure and the readings will be affected by changes in weather systems. It is possible that your altimeter will indicate increases in elevation due to an oncoming trough of low pressure even though you have not moved.

A GPS unit does not give an accurate enough reading to guide the search team on a contour search. Only altimeters should be used. Also, during a contour search, you will wear out much more quickly as you are constantly traversing across a slope in one direction (sidehilling).

Other Sweep Searches

Generally speaking, any method that gives a quick, but not particularly thorough, search of an area is classified as a Sweep Search Method. For this reason, sweep searches by fixed wing aircraft or helicopters may be considered sweep searches. Dog searches where the dog is working back and forth in a particular area rather than just following a trail could also be so classified as a sweep search.

Forward Looking Infrared (FLIR)

A Forward Looking Infrared (FLIR) unit mounted on the bottom of a helicopter and flown over a search area will give an image of the ground based on temperature differences. The on-board monitor shows the outline of objects based on these temperature differences. In the right conditions, humans and other mammals are easily identified on the screen.

Ideal conditions for identifying subjects are cool or cold temperatures and little forest cover. Poor results can be expected if the ground is warm (no difference to the subject's temperature) or there is an obstruction or dense canopy of trees. Also, it is easy for gaps of unsearched area to be left between the passes of the helicopter. Success has been extremely limited but it should improve with newer technology and further training for the operators.

Before a FLIR mounted helicopter is flown over a search area, the searchers on the ground should confirm with the FLIR operator on how they will identify themselves. A common signal to identify the searchers as not being the subject is for the searchers to hold their arms straight out from the body. The arms should not be above the head as this looks like someone waving for help.

Under ideal conditions FLIR is a useful search tool but it shouldn't be assumed that an area searched by FLIR has been completely searched until it has been searched until a thorough ground search has been conducted.

Search Dogs

Search Dogs were covered in Chapter 15 - Type I Search Methods - Initial Response Searches.

Multiple Sweeps

One simple variation of the methods just described is to do a second sweep of the same area using compass bearings differing by 90° from the bearings used in the first sweep. Conducting two, Sweep Searches, at right-angles to each other can produce nearly the same degree of thoroughness as the more time consuming "closed-grid" search described in the chapter "Type III Methods – Closed Grid Searches".

Additional Reading

Collwell, Martin. *New Concepts for Grid Searching*. ERI Inc., Olympia, WA.

Collwell, Martin. *Sound Sweep: a New Tool for Search Teams*. ERI Inc., Olympia, WA.

Collwell, Martin. *Conducting a Sound Sweep – Instructions to Search Teams*. August 31, 1996.

Provincial Emergency Program, Justice Institute of BC, Emergency Management Division. *Search and Rescue Management*. 1989

Provincial Emergency Program, Justice Institute of BC, Emergency Management Division. *Ground Search Team Leader Manual*. 1997

Further references listed in the Bibliography.

Chapter Review

Please answer the following questions on a separate sheet of paper so that another student can use this manual. The answers to these questions are located at the end of the manual.

1. What type of subject is a sound sweep looking for?
2. What are sweep searches?
3. What is the difference between a contour search and a feature search?
4. What are ideal conditions for the use of FLIR?
5. How does a SAR Manager decide what type of sweep search to use?

Answer **True** or **False** to the following statements:

6. All people involved in a sound sweep start from the baseline at the same time.
7. Visual sweeps are generally more efficient than sound sweeps for responsive subjects.
8. With visual sweeps you can always see the next searcher over.
9. Multiple sweeps are conducted at 180° to the first sweep.
10. The length of time between whistle blasts on a trail sweep may be as little as 30 seconds.



Chapter 17 - Type III Search Methods - Closed Grid Searches

Upon completion of this chapter, you will be able to:

- Explain the theory, reasoning, and limitations of closed grid searches.
- Be able to mark off an area for a closed grid search with a base line and datum line.
- Demonstrate how to space searchers in the line and the techniques searchers can use to maintain this spacing.
- Outline the responsibilities of individual searchers in the line.
- Demonstrate the commands that are appropriate for use in Type III searches, including the use of whistles.
- Function in a closed grid team.

Introduction

Some searches will reach a stage where Initial Response and Sweep Searches have been unsuccessful in finding the missing person. A more thorough search of the higher probability areas may be required. This situation will normally result in a “closed grid search” being conducted. The searchers are lined up in a row with a searcher spacing of 10 m or less. Four conditions should be satisfied in order to use this technique:

- The search area should be relatively small area (less than 1 km²).
- There seems to be a high probability of either finding the victim or finding a strong clue to the victim's whereabouts in the search area.
- There should be a large number of trained searchers available who cannot be more effectively used elsewhere.
- The subject is likely hiding, unresponsive or dead.

The necessity for satisfying these four conditions can best be understood by consideration of Table 17-1.

Grid Search Data

Searcher Spacing (m)	Probability of detection	Searcher-hours for 1 sq. km.
40	33% (1/3)	55
20	67% (2/3)	110
10	83% (5/6)	220
5	92% (11/12)	440
2	97% (29/30)	1100

Table 17.1 POD and Searcher Hours at Several Different Searcher Spacings

The figures in the table are derived from data based on studies conducted in moderately dense bush in Washington State. The original figures may be found in several papers including one on Grid Search Techniques by Syrotuck (1974). The figures are approximate and are intended only as a rough guide.

What should be apparent from the figures is that closed grid searches take a lot of time to cover a small area.

Closed Grid searches should be used as a last resort.

In spite of this, there are search situations, as mentioned above, where closed grid searches should be used. The coordination of this type of search is described in the sections that follow.

Initiating a Closed Grid Search

Closed grid searches will normally involve searcher spacings of less than 10 metres. A closed grid search team will usually consist of between 6 and 10 searchers and a Ground Search Team Leader. Experience has shown that having more than 10 searchers in the line creates an unmanageable situation. The area to be searched needs to be marked out carefully in advance.

In marking out an area for a closed grid search, the first requirement is a **base line**. Ideally, this base line will be a long straight section of a road or trail, or some natural boundary such as a river. If no such boundary already exists, a base line can be created by hanging flagging tape at regular intervals. A **sweep boundary** at the point at which the sweep ends should also be marked. **Datum lines** running at 90° to the baseline should be marked at each end of the search area. The outside boundaries of each search teams swath should also be flagged. When flagging the different lines, the tape should be hung so that from any tape the next 2 tapes can be seen. This procedure prevents searchers wasting time looking for the next tape.

A flagging team can work well in advance of the search team and mark off a large number of strips to be searched. Such a team must be skilled in following bearings precisely. As a result of defining the boundaries just described, the area to be searched will be laid out in a manner similar to the situation illustrated in Figure 17-1. The flagging team will also have the opportunity to conduct an open grid search as they mark the lines.

The flagging of several strips in advance allows the search teams to concentrate completely on searching and permits teams to work in adjoining areas independently. It is also much more likely that the flagged lines will be along the desired bearing.

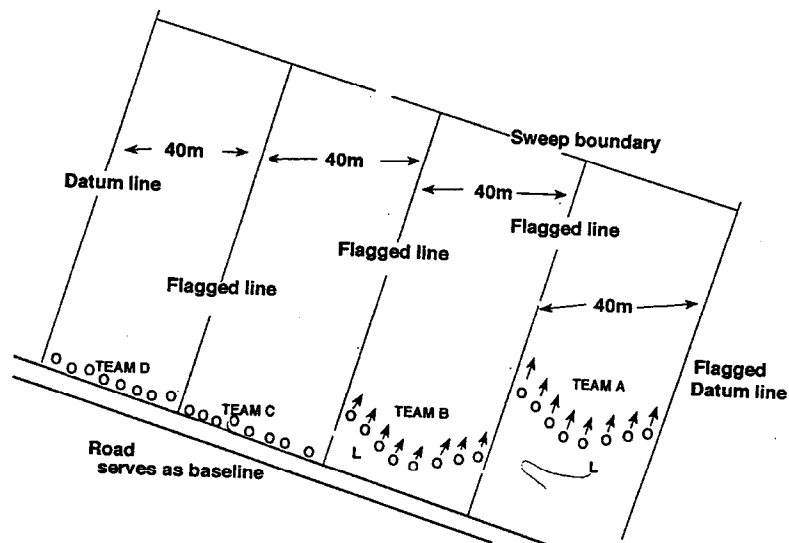

Figure 17.1 Area Marked for a Closed Grid Search

The width of each team's sweep will be the space between searchers multiplied by the number of searchers in the line. For example 8 searchers spaced 5 m apart the sweep width will be 40 m. The two outside searchers are only $\frac{1}{2}$ of the spacing distance (2.5 m) from the flagged sidelines. This maintains the 5 m spacing between this search team and the adjacent search team.

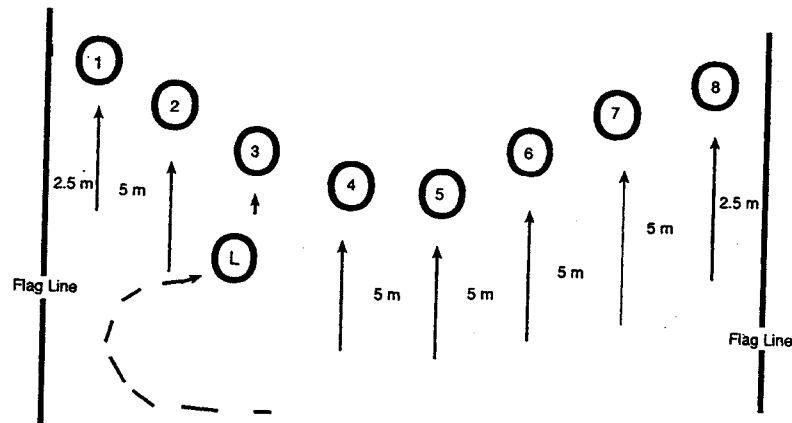

Figure 17.2 Arrangement of an 8 person search team

Closed Grid Team Operation

Searchers must be extremely thorough in this type of search as failure to locate a victim or clue within the area can be taken as reasonably conclusive evidence the victim or clue is not there. After being searched once by a closed grid an area will probably not be searched again.

Being thorough involves looking in all directions, including backwards and even upwards in the trees. It also involves checking any possible hiding place, and as with all types of search, looking not only for the victim, but also for clues. Anything that does not appear natural should be reported. Searchers should approach their work with the positive expectation of finding something of significance rather than with the pessimistic attitude of finding nothing.

In order to begin a closed grid search, the searchers line up along the baseline. The end searchers are at $\frac{1}{2}$ the searcher spacing from the flagged sidelines. For a team of 8 with a searcher spacing of 5 m, the line would appear as in Figure 17.2.

Before starting, the Ground Search Team Leader, (GSTL), reminds all the searchers of the signals to be used.

- One whistle blast from anyone means stop
- 2 whistle blasts from the GSTL means go
- 3 whistle blasts from the GSTL requires the searchers to number off (see next page)

The GSTL then floats behind the searchers, giving the commands for starting and stopping, and working to maintain uniform spacing.

In a closed grid search, searchers try as much as possible to walk a straight line parallel to the datum line. To achieve this, the end searchers (1 and 8 in the diagram) follow the flagged boundaries as a guide. The searchers on the left side of the line (2, 3 and 4 in the diagram) use the searcher immediately to their left as a guide. The searchers on the right side of the line (5, 6 and 7 in the diagram) use the searcher immediately to their right as a guide.

The biggest problem in co-ordinating a closed grid search is maintaining correct spacing. One way of reducing this problem is staggering the line. Each searcher follows several metres behind the neighbouring searcher who is her guide. With this arrangement the searcher does not have to turn her head completely left or right to see her guide. The guide is more frequently in view and maintenance of correct spacing should be slightly more automatic. The appearance of the resulting line will be similar to that shown in Figure 17.2. For this method to work, the "sagging" line must be maintained.

The team leader monitors the spacing and orders corrective action when necessary. For spacing to be maintained in this way, it is essential that no searcher get too far behind or too far ahead. If a searcher does get too far behind, a stop command should be given to the team so this person can get back in line.

ADDITIONAL CONSIDERATIONS

String Lines

One method of marking boundaries that can define areas quickly and accurately is the use of string lines. Hip chains or large rolls of light string, preferably brightly coloured, can be used to divide a search area into distinct blocks. As with flagging tape, every attempt should be made to remove such lines when the search is completed.

Communications

It may be difficult for the Ground Search Team Leader (GSTL) to communicate directly with all members of the team when the bush is dense and the spacing is large. An additional command may prove useful in these circumstances. Before starting the sweep, the searchers number off from one end of the line to the other. Later, when the line has stopped (1 whistle blast) for some reason, the GSTL may give **3** blasts of a whistle. **Three (3) blasts of a whistle requires searchers to call out their numbers in order.** The searcher who gave the stop signal does not respond when the count reaches his or her number. The leader then knows the source of the stop signal and can respond accordingly. Again, the GSTL must be sure this signal is fully understood before searching commences. The numbering off procedure is not recommended when more direct communication is possible.

Once the GSTL has determined that the line can move again he gives 2 whistle blasts.

Difficult Areas

Whatever method is used, **maintaining the line is the responsibility of every searcher in it.** A searcher getting behind must not be forced into superficial searching in order to catch up to the rest of the line. Any area within a search grid that proves so difficult to search that the line will be held up for an extended period of time should be flagged off, noted and searched later by a different crew.

Multiple Teams

When several teams are working in adjoining sections, it is most unlikely that they will reach the sweep boundary simultaneously. To avoid confusion with signals between two teams, it is best if the teams are staggered in the search area.

Before starting a return sweep in a different section, the GSTL must be sure that another team is not already searching the new area. Co-ordination between GSTLs is obviously essential and each GSTL must carry a radio. Attaching a special tag at the ends of a completed sweep can provide useful information to other teams. This tag may be a card with relevant information filled in, or it may simply be some additional flagging tape attached according to a standard code known to all teams.

Closed Grid searches do not represent an efficient use of SAR personnel. They should only be used in the exceptional circumstances as previously outlined.

Additional Reading

Provincial Emergency Program, Justice Institute of BC, Emergency Management Division. *Search and Rescue Management*. 1989

Further references listed in the Bibliography.

Chapter Review

Please answer the following questions on a separate sheet of paper so that another student can use this manual. The answers to these questions are located at the end of the manual.

1. When is a grid search appropriate?
2. How is line spacing maintained in a grid search?
3. Draw how an area is flagged before a grid search is conducted?

Answer **True** or **False** to the following statements:

4. One whistle blast means go and two whistle blasts means stop.
5. The grid team waits for searchers to search difficult areas.
6. Closed grid searches should be used as a first resort.
7. When the search line is stopped, three blasts from a whistle signals the searchers to number off.



Chapter 18 – Shoreline Searches and Safety

Upon completion of this chapter, you will be able to:

- Describe the urgency of water-related searches.
- Describe the strategy used in river and lake searches.
- Outline basic river hydrology.
- Identify swiftwater hazards.
- Describe appropriate equipment for working within 3 m of swiftwater.
- Describe basic swimming techniques.
- Describe various stream crossing techniques.
- Discuss and demonstrate use of a throw bag.
- Discuss what is meant by Reach, Throw, Row, Go, Helo.

Shoreline Searches

Accidents on or around rivers or lakes often lead to searches for missing people. These accidents can occur as people boat, fish or even just walk along the shore of a river or a lake. In fact, in BC the drowning rate is twice the national rate. Most drownings are the result of boating accidents with a high percentage being alcohol related.

As a GSAR team member, undoubtedly you will be called on to be part of a search around water. No matter what the reason is for the water search, searcher safety must be maintained.

SAR incidents that involve water are divided into searches and rescues. Water rescues, especially whitewater rescues, take considerable training and experience. Water rescues will not be covered in the GSAR course. Water rescues are covered in the Swiftwater Rescue Technician 1 (SRT 1) course that has been developed and is delivered by Rescue Canada. The SRT 1 course is for those volunteers having an interest in swiftwater rescue and who have the opportunity to train in that environment.

Only Swiftwater Rescue Technicians should venture into the water during a SAR incident and those who stay on shore need to have basic self-rescue training and adequate equipment. In this chapter we will discuss river bank and lakeshore search strategies and searcher safety.

River Searches

River searches occur whenever anyone goes into the water and is swept away. River searches are also necessary whenever there is a person lost in the vicinity of a river, since falling into the river is a likely reason for the person's disappearance.

Whatever the reason for the person being in the river, the possible outcomes are similar. If the subject does not drown he or she will be carried downstream until they are:

- able to get out of the river onto one of its banks
- trapped against a log-jam, a rock or some other obstacle
- able to get out of the river onto a rock or a small island

The second and third situations may require rescue techniques beyond the scope of a GSAR course. The GSAR team member may still be involved in locating a trapped subject but a swiftwater rescue team is brought in to conduct the rescue.

Many rescuers have died trying to perform rescues that they are not trained for.

River Search Strategy

A subject may float considerable distances downstream before being able to reach shore and get out. Once the subject has escaped the river, he may have crawled up the bank and into the woods, either to seek shelter or from disorientation resulting from either hypothermia or injury.

Because of the threat of hypothermia all river searches require a high-urgency response.

As with any search the point last seen (PLS) has to be determined. If the PLS is in the river then this point will be the top of the search area unless there is reason to believe that the subject has gone upstream.

The bottom of the search area is calculated by determining the river current speed and multiplying it by the time since the person was last seen (e.g. 3 km/hr (current speed) X 2 hours = 6 km downstream). Often actual measurements are not taken and the bottom of the search area is determined from local knowledge.

A confinement team is placed downstream beyond the bottom of the search area to ensure that the subject is not swept out of the search area.

Initial response teams are sent to quickly search the river and river banks downstream from the PLS. They may utilize boats, vehicles or aircraft. Usually a combination of these resources is used. Any searcher who is on the river has to be certified as a Swiftwater Rescue Technician.

The types of boats that may be used are zodiacs, rafts, kayaks or aluminium jet boats. The normal boat procedure is for a fast boat to cover the area quickly and for slower boats to conduct a more thorough search once the initial search is completed.

Vehicles are used to drive down riverside roads checking river banks that are visible from the road and checking whether the subject has escaped the river and is on the road. Access points to the river are checked in case search teams have to be deployed.

If available, aircraft may be used as they can cover the river very quickly and if the river is relatively clear spotters can see submerged objects that would normally be unseen from a boat. The disadvantage is that they cannot see into the bush on the river bank and are often not available.

As the subject may be in the river bank bush, GSAR teams are sent to search the river banks downstream from the PLS. The strategy is to have numerous small teams searching different spots along the banks to cover the search area as quickly as possible. Ideally, several teams will be searching each bank, the starting point for each team is dependent on access points to the river. Figure 8.1 illustrates this typical situation.

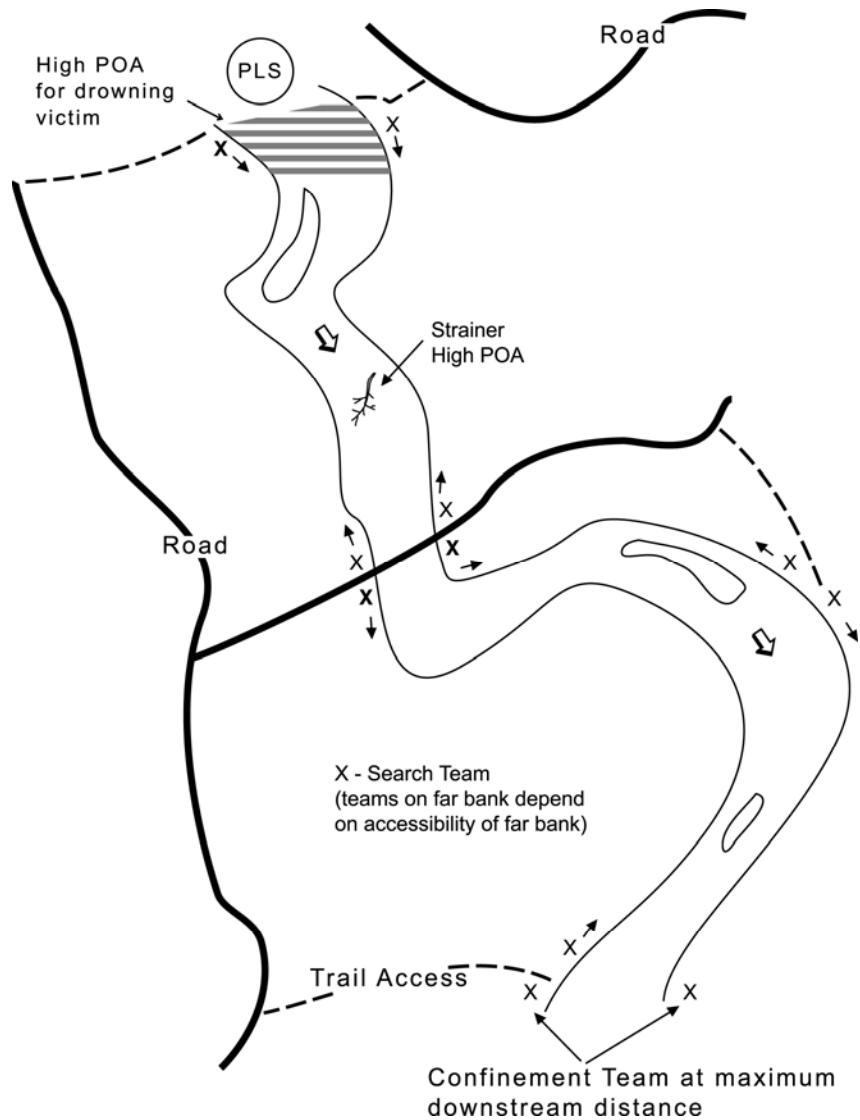

Figure 18.1 River Search

Teams of three are desirable (two is the minimum) with each team having a radio. Any person near the water should be equipped with the appropriate gear such as helmet and personnel flotation device. Personal safety is discussed later in this chapter.

The teams should search the woods a short distance away from the side of the river looking for any evidence of the subject having left the river. The subject's name should be called and whistles blown however, river noise may make this ineffective. The first search should be quick and concentrate on finding a live body. A more thorough search can be done later if the initial search is unsuccessful.

The searching of some river banks can be very hazardous and under no circumstances should the lives of searchers be endangered. Canyon areas may have to be bypassed, but attempts

Drowning Victims

should be made to find a viewpoint from which the canyon can be scanned in case the person is trapped within it. Rope Rescue Team members can use a belay to assist in searching slightly treacherous areas. Only personnel with the training to deal with the hazards should enter hazardous areas.

There is always a possibility that the subject has drowned. Drowning victims tend not to travel far in rivers. The body tends to end up in one of the following places which should be carefully observed:

- Trapped by the current against a log-jam or sweeper.
- Against the upstream side of a rock or other obstacle.
- Beached in a shallow area where the water is moving more slowly.
- At the bottom of a deep pool where there is little current.

Seeing to the bottom of a deep pool can be very difficult owing to light reflection. Finding a vantage point which permits looking down into the pool will improve the detectability of any object at the bottom of the pool. The use of polarizing sunglasses will greatly aid the searching of pools.

Often when a subject has been lost in a river at high water the body will not be found. The search team may have to return numerous times as the water level drops before finding the subject. In one case in BC, it took three and a half months before the water level was low enough to expose the body.

Glacial Streams

Sediment loaded streams that originate from glaciers occasionally take the lives of people travelling through the mountains. Usually, the accident happens when the person tries to cross the stream when the water level is too high or the person slips off a rock when trying to jump across the stream. Once in this very cold water the subject's strength is consumed and they can not swim for very long.

The water level of most glacial streams will fluctuate over the course of a day. The glacier melts faster during the day and melts slower at night. Since the melted water has to travel down the stream, there is a time lag between when the ice melts and when the stream is highest. The water level is usually lowest in the morning and is higher in the afternoon and evening. The best time to search for a body is in the morning when the stream is at its' lowest.

Lake Shore Searches

Searching a shore of a lake for a missing subject is similar to searching a river bank. You are looking for any sign that the victim came out of the water. Beaches of sand or dirt are good track traps and should be checked by SAR teams. If no sign is found on the beach, there is a good chance that the subject did not leave the lake at that point. However, many lakes in BC have rocky or brushy

shores that take considerable more care and expertise to detect sign and to confirm that the person has not left the lake area.

While looking for clues or bodies on lakeshores pay special attention to the direction of the wind. Debris will move to the downwind shore from the incident. On most lakes, debris accumulates in one area indicating the direction of the wind and a good place to start searching.

Body Recovery

You may happen to be a member of a team that finds a body that has been in the water for a period of time. This can be one of the most difficult experiences for a member of a SAR group to deal with. Bodies that have been submerged for a long period of time are horrendous in their smell and appearance.

Rubber gloves, facemasks and waterproof, airtight body bags need to be used for the recovery. Some members use a dab of Vick's Vapo-Rub underneath their nostrils to mask the smell.

If you have been involved in a body recovery you should be aware of how you and your fellow team mates are handling the incident and a critical incident stress debriefing should be arranged. The Search Termination chapter contains further information on CISD.

RIVER SAFETY

GSAR members who are searching along river banks need to know some basic safety information. The following section of this chapter deals with the basics of safely working around rivers when called on to do a search.

River Orientation

While working around a river you need to be able to describe your location to base and to other team members. Positions on a river are described from the perspective of looking downstream. River right is the right side of the river looking downstream while river left is the left side of the river looking downstream.

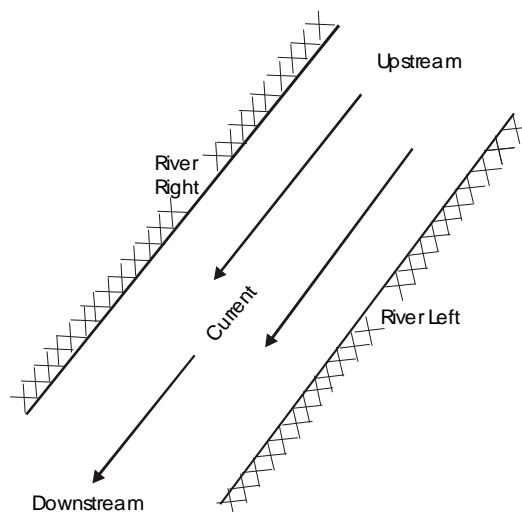

Figure 18.2 River Orientation.

River Hydrology

Once water starts moving downhill it is considered swiftwater. What changes the behavior of the swiftwater is the volume of water, how fast it moves and the surface that it runs on (riverbed and banks). There is greater force with more volume or a steeper drop.

Cross River Section

River Cross Section

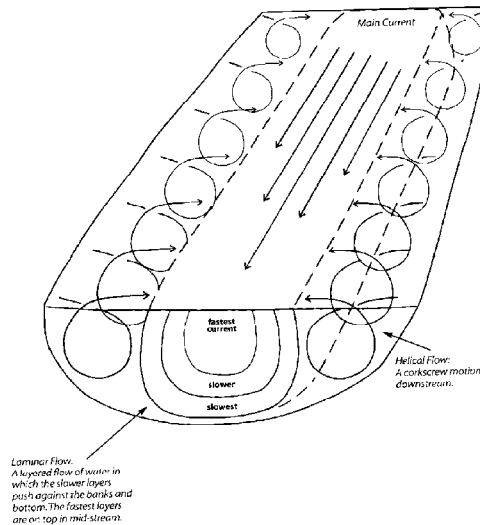

Publisher: CFS Press Author: S. Ray Title: Swiftwater Rescue

© This material has been copied under licence from CANCOPY. Resale or further copying of this material is strictly prohibited.

Figure 18.3 Types of Current in a River

Laminar and Helical Flow

There are two types of current in a river; the laminar flow that is in the middle of the river and helical flow of water along the banks. Laminar flow moves straight down the river while the helical flow corkscrews down the side of the river, due to the friction of water against the bank that slows the outside water. This helical flow can sometimes sweep subjects out into the laminar flow and make it difficult for swimmers to get to shore.

River Bends

As a river bends around a curve the current is fastest on the outside of the bend and slowest on the inside of the bend. The faster current on the outside of the bend erodes the bank while the slower current on the inside drops suspended material such as sand.

Eddies

As water moves around an object such as a rock it forms an eddy. An eddy is the movement of water upstream behind an object in the water. An eddy fence is a line in the river that separates the current moving downstream from the current moving upstream. Crossing over an eddy fence to get in or out of an eddy, from a boat or as a swimmer, takes more force than moving in regular current.

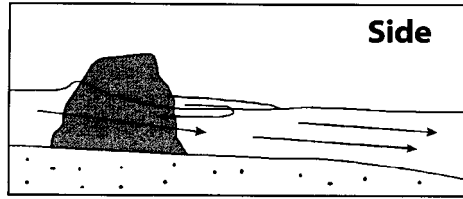
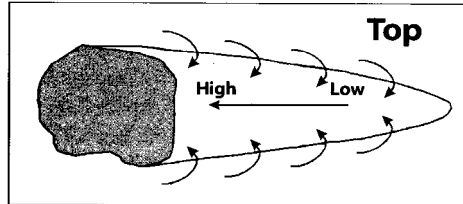

Fig. 2.5 An eddy is formed by an obstacle in the current.



Publisher: CFS Press Author: S. Ray Title: Swiftwater Rescue

© This material has been copied under licence from CANCEOPY. Resale or further copying of this material is strictly prohibited.

Figure 18.4 How an Eddy Forms

Standing Waves

Waves in rivers are called standing waves because they stay in one spot. They can occur in a number of spots on the river such as where the water flows over an object, the current changes speed, or there is a narrowing in the width of the river.

RIVER HAZARDS

Extra caution has to be taken if you see any of the following hazards in the river while searching along the riverbank. You may have to avoid searching certain areas if there are too many hazards.

You do not want to fall in the river above any hazard.

Hydraulics and Holes

A hydraulic (keeper or reversal) forms when water pours over the top of an object and the current reverses back upstream (Figure 8.5). The water is aerated (40-60% air) and appears white and foamy. The current in a hydraulic can hold an object for a long period of time.

A hole is considered to be a standing wave that breaks back upstream. It is not as dangerous as hydraulics as more water moves downstream at the bottom of a hole allowing an object such as a swimmer to be washed downstream. However the terms hydraulic and hole are often used interchangeably.

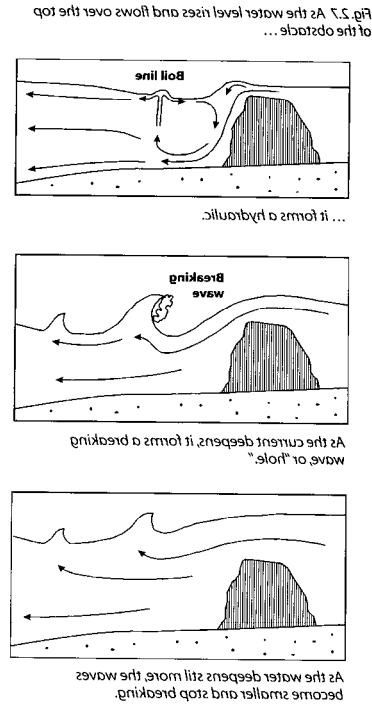

Publisher: CFS Press Author: S. Ray Title: Swiftwater Rescue
 © This material has been copied under licence from CANCOPY. Resale or further copying of this material is strictly prohibited.

Figure 8.5 Hydraulics and Holes

Holes come in two types: frowning and smiling. When looked at from upstream they resemble their namesakes. A frowning hole tends to keep objects by recirculating on itself while a smiling hydraulic tends to flush objects out.

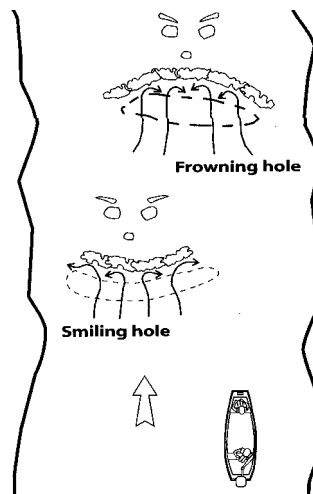

Publisher: CFS Press Author: S. Ray Title: Swiftwater Rescue
 © This material has been copied under licence from CANCOPY. Resale or further copying of this material is strictly prohibited.

Figure 18.6 Smiling and Frowning Holes

Strainers

Strainers are solid material in the river that allows the water to flow through but which would stop a solid object like a boat or body. The most common strainers in BC are trees but other types of strainers include boulders, fences and other man made objects. An object held against a strainer will be difficult to move because of the force of water pushing against the object. It is surprising how little current it takes to hold an object against a strainer.

Cold water

Most rivers in BC are very cold and anyone who ends up swimming in the river could potentially get hypothermic. A more immediate threat is the loss of strength from the cold water that can lead to drowning. It is extremely important for searchers who fall into the water to get out as quickly as possible.

Entrapment Hazards

Foot entrapment in crevices and cracks is a potential hazard as most rivers have rocky bottoms and banks. When a swimmer stands up in deep, moving water and their foot gets trapped, they are pushed forward by the current. They cannot free themselves because of the force of the current and drowning often occurs.

If you end up swimming in a river and you are nearing shore do not stand up until the water is very shallow. This will lessen the likelihood of foot entrapment.



Publisher: CFS Press Author: S. Ray Title: Swiftwater Rescue

© This material has been copied under licence from CANCOPY. Resale or further copying of this material is strictly prohibited.

Figure 18.7 Foot Entrapment

Bears

Extra care has to be taken while searching along creeks and rivers (especially those with spawning fish in them) as these areas attract bears. The information on bear avoidance contained in the Survival Chapter should be reviewed at this point.

Tying Into a Rope	Never tie directly to a rope without a means of releasing the rope. If you get swept downstream while tied to a rope that you cannot release, when the rope will goes taut the current will force you under water and you will drown.
Lines Across the River	Lines that cross a river in the water should never be at 90° to the current. In this position the line can trap a person on the upstream side. An angled line across the river will allow the person to move down the line and out of the current.
PERSONAL EQUIPMENT	To work safely in the swiftwater environment some personal equipment is mandatory. Therefore, if you are searching within 3 m of swiftwater you must wear the appropriate safety gear. The minimal gear required is a helmet, a personal flotation device (PFD), a knife, a whistle, and proper footwear.
Personal Flotation Device (PFD)	PFDs are rated according to the amount of flotation they provide. A PFD with 18 –24 lbs is the recommended minimum. Ensure that the PFD fits you properly and that movement is possible when it is on. It is difficult to swim with an overly bulky PFD. Horsecollar PFDs are not to be used in swiftwater.
Helmets	Helmets are important to protect the head from impacts with rocks both when walking around the shore and if being swept downstream. A lightweight, ventilated helmet which protects the forehead, and the sides and back of the head and does not have a rim is recommended.
Hoods	The head is a major source of heat loss. A searcher must have a neoprene hood or pile cap to keep warm. Make sure that it can fit under your helmet.
Footwear	The proper footwear can provide protection and warmth. The types of footwear range from runners and wool socks to neoprene booties with thick soles.
Knife	A knife is an essential piece of equipment to have while working around swiftwater. The knife would be used to free either the victim or the rescuer if entangled in line. The usual knife used is a straight blade in a positive locking sheath attached to the shoulder of the PFD.
Whistle	In the swiftwater environment it is often difficult to vocally communicate with people so a whistle becomes very important. It is essential that the whistle can function when wet (i.e. Fox 40).
Throw Bag	A throw bag is an important part of any swiftwater operation. It is a length of rope (made of various materials) inside a nylon sack. Often, on river operations, SAR members are stationed downstream from an incident. Equipped with throwbags, SAR members will provide downstream safety in the event that subjects or rescuers are swept downstream.

Swimming Techniques

If, while searching, you happen to fall into a river it is important to know the correct procedures to self-rescue. The most important objective is to get to shore as quickly as possible. Once in the water you will want to get into the swimming position. This position is on your back with your feet downstream and raised up. This will prevent your feet from becoming trapped on underwater hazards. Scan down river to identify any hazards.

You also want to keep your feet pointed towards hazards such as rocks and use them to fend off these hazards.

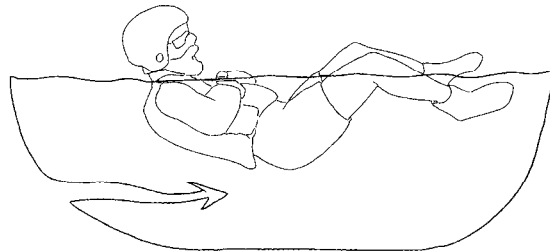

Publisher: CFS Press Author: S. Ray Title: Swiftwater Rescue

© This material has been copied under licence from CANCOPY. Resale or further copying of this material is strictly prohibited.

Figure 18.8 Correct Swimming Position.

Swimmer's Ferry

To move toward shore use the swimmer's ferry. This is to have your body at 45° to the current, head upstream and pointed towards the shore you want to go to. Back paddle and the current will help move you towards shore.

If you want to move more quickly roll on to your stomach and do the front crawl towards shore. Keep your head upstream and maintain a 45° angle to the current.

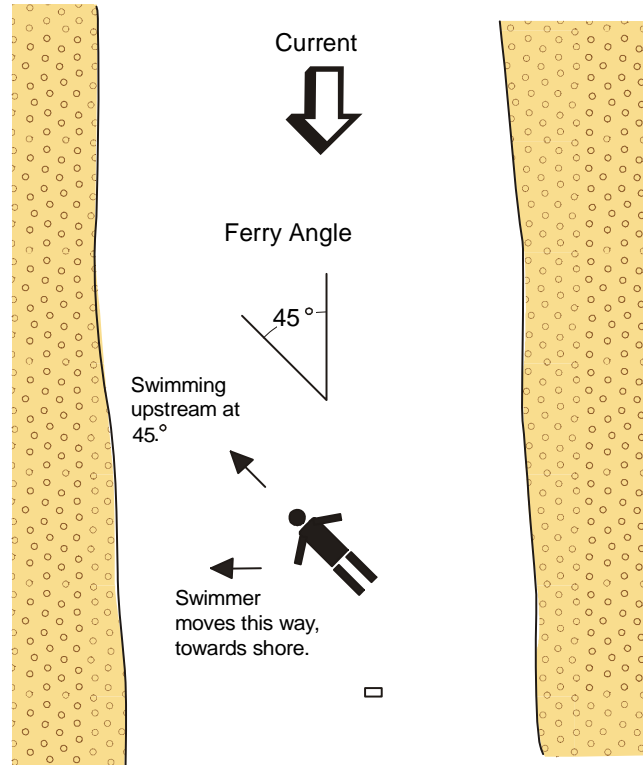

Figure 18.9 Swimmer's Ferry

Avoiding Strainers

If you are heading towards a strainer and cannot avoid it by using the swimmers ferry, the best thing to do is to get on top of the strainer. Approximately 5 metres before the strainer, roll on your stomach and swim as quickly as you can towards the strainer to pull yourself up on top of it.

Stream Crossing

Often in searches it may be necessary to cross streams without a bridge. It is necessary to know what type of stream is safe to cross and what techniques should be used. Crossing creeks and streams can be one of the most dangerous activities on a search.

The factors that have to be considered before crossing a creek are the depth of water, current, channel bottom, any downstream hazards and suspended material in the water. If the water level is above your knees there is a definite risk of being knocked over and swept downstream. However, any depth of water can be dangerous if the current is very strong or the stream bottom is very smooth. In addition, look downstream for hazards such as waterfalls or rapids. Hazards downstream increase the risk of even easy crossings. The decision to cross should only be made if it is unlikely that you will be swept off your feet and there are no hazards downstream.

Techniques for Crossing

Any time you decide to cross you have to be prepared to swim. Therefore before crossing you should unfasten your pack's waist and chest straps so that it can be removed quickly if you fall in. A loaded pack will drag you under water very quickly.

If you decide to wade across a stream, pick the widest point in the stream where the water is the shallowest. If the stream bottom is at all rocky it is best to leave your boots on but remove your socks and insoles.

Time of day can also be an important consideration when crossing creeks. The water level is usually the lowest in the morning as there is not as much melt water flowing down the creek. As the day progresses, the water level increases, and a stream that would be easy to cross in the morning may become impassable in the afternoon.

Single Person Crossing

The best way for a single person to wade across a stream is for the person to face and lean upstream using a pole as a third point of contact. As you move sideways across the stream you always have at least 2 points of contact.

Group Crossing

There are a number of formations that can be used for a group to cross a stream. One formation is to be in a straight line parallel to the current with all members facing upstream. The front person of the line leans onto a pole and into the current. This front person breaks the current for the rest of the group. Each person holds onto the person in front of them for support. One person at a time moves sideways, starting with the person at the front of the line (Figure 18.10).

Another formation that can be used is to cross in a triangle shaped group (a wedge) with everyone facing upstream. The point person is the farthest upstream breaking the current and leaning on a pole for support.

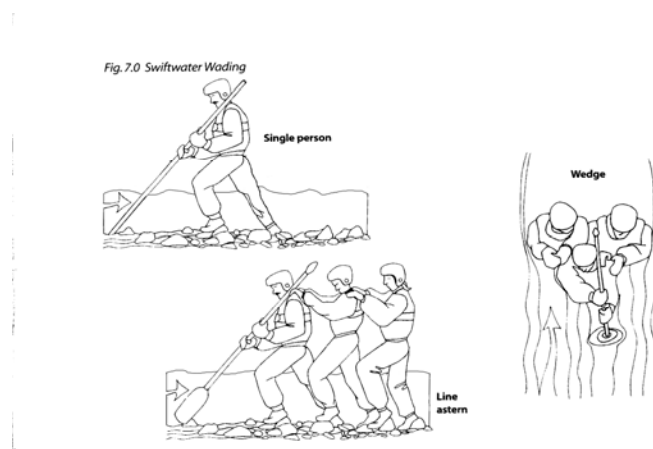

Adapted from Publisher: CFS Press Author: S. Ray Title: Swiftwater Rescue

© This material has been copied under licence from CANCOPY. Resale or further copying of this material is strictly prohibited.

Figure 18.10 Stream Crossings

Reach, Throw, Row, Go, Tow, Helo

In forested areas, fallen logs to walk or crawl across often are the safest, easiest way. Poles or hand lines for balance can assist in crossing on the log. Jumping from boulder to boulder is another way to cross a stream. Make sure you do not overestimate your jumping ability or underestimate the slipperiness of the rocks.

For rescue operations in swiftwater, one should remember the axiom Reach, Throw, Row, Go, Tow, Helo. However, it should also be remembered that many potential rescuers have died in swiftwater rescues trying techniques they are not trained for. As a GSAR member, only the reach and throw rescue techniques should be attempted.

Reaching with some sort of equipment such as a paddle is the safest form of rescue and should be attempted first. Always reach with an object and not your hand. If you start to get pulled in you can release the object and not get pulled in.

Throwing a throw bag is the next safest as the rescuer is still not in the water. More risky is Rowing a boat and Going and Towing which should only be attempted by Swiftwater Technicians. Finally, helicopter rescues in the swiftwater environment should only be used if all other rescue techniques have been tried.

Use of a Throwbag

Throwbags are one of the most often used pieces of swiftwater rescue equipment. As a GSAR team member you may be asked to provide containment downstream of an activity. To perform this duty you will have to be wearing the proper personal safety gear and have a throwbag. Your duty is to watch for any person swept downstream and use the throwbag to safely bring the swimmer into shore.

When using a throwbag do not loop the rope around your wrist or tie into the rope. Hold the bag in one hand, open the top of the bag and grab the end of the rope in the other hand. Wetting the bag makes the bag easier to throw. Yell to alert the subject and throw the bag with an underhand or overhand toss. Aim to throw past the subject and slightly ahead of them. Once the subject has the rope, draw them into shore in a broad arc while trying not to totally submerge them. Walking down the riverbank prevents you from being pulled into the water when the rope becomes taut.

If you are the person in the water receiving the throwbag, grab the throwbag and get onto your back (if you are not already there). Put the line across your chest and over the shoulder that is farthest away from the shore. Perform the swimmer's ferry with your head pointing upstream to the shore so you will be pulled in to. When the line goes taut expect some water to come over your head.

Additional Reading

Croslin, Mike, Edwards, Barry and Segerstrom, Jim. *Swiftwater Rescue Technician*, 2nd Edition. Elkgrove CA: Rescue 3 / Rescue Source, 1991.

Ray, Slim. *Swiftwater Rescue*. Asheville, NC: CFS Press, 1997.

Further references listed in the Bibliography.

Chapter Review

Please answer the following questions on a separate sheet of paper so that another student can use this manual. The answers to these questions are located at the end of the manual.

1. Where are you most likely to find a live missing person on a river?
2. What might you do to smoothly bring to shore a subject to whom you have thrown a throw bag.
3. Describe the technique for a single person to wade across a stream.
4. What is the function of downstream containment?
5. What is the minimal equipment required by shoreline searchers?

Answer **True** or **False** to the following statements:

6. Looking upstream river right is to your right.
7. River searches require a high-urgency.
8. An eddy forms when water flows over an object and the current reverse back upstream.
9. A line across a river that is in the water should be at 90° to the current.
10. A glacial fed stream is at it's highest water level in the afternoon and evening.



Bibliography

UNIT NAME

Books

- Auerbach, Paul S. *Wilderness Medicine*. St. Louis, MO: Mosby – Year Book Inc., 1995.
- Bigon, Mario and Regazzoni, Guido. *The Morrow Guide to Knots*. New York, NY: William Morrow and Company, Inc., 1982.
- Brewer, Dave and Brewer, Gerry. *How to Organize a Search and/or Rescue (A Handy Reference Guide)*. New Westminster, BC, Justice Institute of BC, 1998.
- Bowman, W.D., *Outdoor Emergency Care*. Second Edition. National Ski Patrol System, Inc, 1993.
- Cooper, Donald C. and Taylor, Albert “Ab”. *Fundamentals of Mantracking: The Step-By-Step Method, 2nd Edition*. Olympia, WA: Emergency Response Institute, Inc. and National Rescue Consultants, Inc., 1993.
- Cooper, Donald C., LaValla, Patrick “Rick” and Stoffel, Robert “Skip”. *Search and Rescue Fundamentals, 3rd Edition*. Olympia, WA: Emergency Response Institute, 1996.
- Croslin, Mike, Edwards, Barry and Segerstrom, Jim. *Swiftwater Rescue Technician, 2nd Edition*. Elk Grove CA: Rescue 3 / Rescue Source, 1991.
- Fear, Gene. *Surviving the Unexpected Wilderness Emergency*. Tacoma, WA: Survival Education Association, 1979.
- Frank, James and Patterson, Donald. *CMC Rappel Manual*. Santa Barbara, CA. CMC Rescue Inc., 1993.
- Graydon, Don, and Hanson, Kurt. *6th Edition, Mountaineering, The Freedom of the Hills*. Seattle, WA: The Mountaineers, 1997.
- Hardin, Joel. *Universal Training Systems Signcut Division (Manual)*. Everson, WA.
- Hawley, Donna L. *Conservation and Outdoor Recreational Education*. Richmond, BC: Open Learning Agency, 1989.
- Industry Canada. Study Guide for the Radiotelephone Operator's Restricted Certificate (Land) No longer produced.
- Kjellstrom, Bjorn. *Be Expert with Map & Compass*. New York, NY: MacMillan General Reference, 1994.
- Kearney, Jack. *Tracking: A Blueprint for Learning How*. El Cajon, CA: Pathways Press, 1978.
- Kelley, Dennis E. *Mountain Search for the Lost Victim*. Montrose, CA: Dennis E. Kelley, 1973.

**Books
Continued**

Kelley, Dennis E. *The \$250, 000 Message*. Salt Lake City: SAR Paper No. 2 76-108, N.A.S.A.R., 1976.

Klassen, Karl. *Association of Canadian Mountain Guides (Manual)*. Banff, AB: The Association of Canadian Mountain Guides, 1991.

Merry, Wayne. *Official Wilderness First-Aid Guide*. Toronto, ON: McClelland & Stewart Inc., 1994.

Provincial Emergency Program, Justice Institute of BC, Emergency Management Division. *Ground Search Team Leader Manual*. 1997

Provincial Emergency Program, Justice Institute of BC, Emergency Management Division. *Rope Rescue Manual*. 1992

Provincial Emergency Program, Justice Institute of BC, Emergency Management Division. *Search and Rescue Management*. 1989

Provincial Emergency Program, Ministry of Attorney General. *Policy and Procedures Manual*. 1998

Provincial Emergency Program. *Search and Rescue Advisory Committee, Information Booklet*. Victoria, BC, 1998.

Ray, Slim. *Swiftwater Rescue*. Asheville, NC: CFS Press, 1997.

Schimelpfenig, Tod, and Lindsey, Linda. *Wilderness First Aid*. Lander, WY: NOLS Publications, 1991.

Sebert, L.M. *Every Square Inch*. Ottawa, ON: Department of Energy, Mines and Resources Canada.

Seidman, David. *The Essential Wilderness Navigator*. Camden, MD: International Marine/Ragged Mountain Press, 1995.

Setnicka, Tim J. *Wilderness Search and Rescue*. Boston, MA: Appalachian Mountain Club, 1980.

Simer, Peter, and Sullivan, John. *The National Outdoor Leadership's Wilderness Guide*. New York, NY: Simon & Schuster, Inc, 1983.

Syrotuck, William G. *An Introduction to Land Search Probabilities and Calculations*. Westmoreland, NY: Arner Publications, 1975.

Vines, Tom and Hudson, Steve. *High Angle Rescue Techniques*. The National Association for Search and Rescue. 1992

Wartes, Jon. *Washington Explorer Search and Rescue Team Member and Team Leader Training (Manual)*. , 2nd Edition. Tacoma, WA: Xerox Ventura Publisher, 1988.

Articles

Wartes, Jon. *Search Area Confinement: An Overview*. National Association of Search and Rescue (NASAR), 1980.

Wiseman, John "Lofty". *The SAS Survival Handbook*. Hammersmith, London: HarperCollins Publishers, 1996.

Brewer, Dave. *Standardized Review Process*. SAR Reference Memo, Provincial Emergency Program. Victoria, BC, 1998.

Bower, Donald C. and Hill, Kenneth A. *GPS Navigation and Land Search*. Waverley Ground Search and Rescue.

Collwell, Martin. *New Concepts for Grid Searching*. ERI Inc., Olympia, WA.

Collwell, Martin. *Sound Sweep: a New Tool for Search Teams*. ERI Inc., Olympia, WA.

Collwell, Martin. *Conducting a Sound Sweep – Instructions to Search Teams*. August 31, 1996.

Foster, Richard. *Patient Packaging for Wilderness Search and Rescue*.

Millar, John, Dr.. *Tick Bites and Disease*. BC Ministry of Health, Victoria, BC, Summer 1994.

Natural Resources Canada, Geomatics Canada. *Topographic Maps*. (Information Pamphlet).

Philip, H.G. Entomologist. *Pest Control Note 93-04 - Ticks and Man in British Columbia*. Province of BC, Ministry of Agriculture, Fisheries and Food. May 1993.

Province of British Columbia, Ministry of Forests. *Bear Aware Student Manual*.

Province of British Columbia, Ministry of Forests. *In and Around Helicopters - Passenger Safety*.

Provincial Emergency Program. *Search and Rescue Advisory Committee, Information Booklet*. Victoria, BC, 1998.

Sprague, David and Woo, Arthur, Trimble Navigation Ltd. *Fundamentals of the Global Positioning System*.

Syrotuck, William G. *Analysis of Lost Person Behavior*. Westmoreland, NY: Arner Publications Inc., 1976.

Workers' Compensation Board. *Safe Work Practices for Helicopter Operations in the Forest Industry*. Richmond, BC, 1995

Articles Continued

The following articles were obtained from the Ministry of Health publication entitled "from the Health files":

- Campylobacter. Number 58, March 1997
- Tick Bites and Disease. Number 1, Summer 1994
- Giardiasis and other Water-Borne Diseases. Number 10, September 1990
- Hepatitis A. Number 33, October 1996
- Cryptosporidiosis. Number 48, October 1997
- How to Disinfect Drinking Water. Number 49b, August 1997
- Rabies: Early Treatment is Essential. Number 07, August 1997
- Wilderness Health Risks. Number 24, February 1992

Web sites

SARINFO at <http://www.sarinfo.bc.ca>

Chris Weddle's "Team Membering, Skills for the Individual" at <http://www.fri.com/~cvw/teammmbr.html>

Declination calculation
http://www.geolab.nrcan.gc.ca/geomag/e_cgf.html

Canadian Avalanche Association web site at <http://www.avalanche.ca>

Chapter Review

Answer Key

Chapter 1 – Search and Rescue in BC

1) Air SAR, Marine SAR and Ground and Inland Water SAR 2) Responsible for Ground and Inland Water SAR 3) SAR Commander (Police Officer) 4) SAR Manager (Deputy Incident Commander) 5) see page 1-10 6) ECC 7) Coroner 8) T 9) F 10) F 11) F 12) F 13) T 14) T 15) F

Chapter 2 – Initiating a Search

1) Of the lost people found dead 50% had died on the first day and the search area grows rapidly with each passing hour. 2) The duty officer (usually a SAR Manager) 3) Sign in and wait for instructions, get your gear ready and study maps 4) PLS is the place where the subject was last seen while the LKP is the last place where the subject was known to have been but the subject may not have been seen there. 5) The rating is 12 but the 1 ratings of several factors makes an urgent response necessary. 6) F 7) F 8) F 9) T 10) F

Chapter 3 – Search Progression

1) Between 1 km and 2.6 km downhill from PLS 2) see page 3-6 3) Field search assignments 4 to 6 hours, operational periods 6-12 hours 4) State the obvious, Police Authority or SAR Manager 5) To find out and record exactly what the team did 6) Locate, Access, Stabilize and Transport 7) Probability of Detection – the likelihood that a team would have found the subject if the subject was in the search area. 8) F 9) F 10) F 11) F 12) T

Chapter 4 – Search Termination

1) The clean-up and preparation for the next search done at the end of a search. 2) Team equipment being taken home and searchers not signing out. 3) An opportunity to improve the SAR response. 4) Observation, comment, suggestion, action, responsibility for action, date action to be taken 5) Police 6) When there no chance that the subject is alive or the subject is not thought to be in the area. 7) Expense claim form filled out by member and given to SAR manager (may vary in some SAR Groups) 8) T 9) F 10) T 11) F 12) F

Chapter 5 – Maps

1) There will be some differences in answers but if you are 2 or more numbers off on the third and sixth digit of a UTM grid coordinate or 10" or more off on your latitude and longitude then recheck your answer.

- a. 892 228; 55° 14' 40" N, 127° 35' 50" W
- b. 891 176; 55° 11' 50" N, 127° 36' 00" W
- c. 945 178; 55° 11' 55" N, 127° 30' 55" W
- d. 922 153; 55° 10' 30" N, 127° 33' 05" W

2) A motel 3) A lake 4) F 5) T 6) T 7) T (when using a 6 digit UTM grid reference) 8) F

Chapter 6 – Compass

1) True North is the true pole of the earth, Grid north is what the grid lines on a map are based on, and magnetic north is the point at which a compass needle points to, Grid north and magnetic north 2) It simplifies compass work 3) Check your own compass! 4) At waist level and the sighting method, the sighting method is more accurate 5) Any iron or steel objects or magnetic fields
6) F 7) F 8) T 9) T 10) F

Chapter 7 – Map and Compass

There will be some differences in answers but if you are more than 2° off on your bearing, or 2 or more numbers off on the third and sixth digit of a UTM grid coordinate or 10" or more off on your latitude and longitude then recheck your answer.

1) 275°, 95° 2) 049 151 3) Latitude 49° 47' 45" N , Longitude 122° 59' 25" W, UTM Grid 007 157 4) Examples of technical terrain: Garibaldi or Lava Glacier, steep slopes and cliffs around Pyramid Mountain or the Gargoyles, swiftwater in Zig Zag or Skookum Creek

Chapter 8 – Survival Skills

1) Stop, Think, Observe, Plan 2) The Will to Live 3) Require Assistance 4) Fight back 5) First aid, fire, shelter, signals, water, food (but can vary depending on circumstances). 6) It is a cold shelter without a fire. 7) In a survival situation you have a limited amount of energy, therefore, the benefits of any action should outweigh the disadvantage of energy loss. 8) F 9) T 10) F 11) F 12) F (if no ready food source is available then more energy may be expended than is gathered)

Chapter 9 – Communications

1) Describe how you are receiving the signal with simple words. 2) A mobile is in a vehicle while a portable is hand-held. 3) It allows the SAR Manager to keep track of what exactly is happening and to keep the communications functioning effectively. 4) Squelch mutes the radio speaker when there is no incoming transmissions. 5) First name – Golf, Echo, Romeo, Romeo, Yankee Second name- Juliet, Oscar, Hotel, November, Sierra, Echo, November 6) 2145, 0347, 1820 7) T 8) F 9) F 10) T

Chapter 10 – Orientation to Rope Management

1) Dynamic rope stretches much more under tension than static rope (low stretch rope). Static rope is used in SAR. 2) On low angle slopes where if the stretcher is dropped it will not slide down the hill. 3) Brake Hand 4) I am in belay position and ready to belay. 5) Do it! 6) F (10 cm, 4 inches) 7) F 8) T 9) F 10) F

Chapter 11 – Orientation to Tracking

1) So that they are more aware of sign and the need to protect sign. 2) The light source can be manipulated to more easily see sign. 3) See the information on the track report. 4) Patience, practice and instruction 5) F 6) T 7) F 8) F

Chapter 12 – Helicopter Safety

1) 35 m (120 feet) 2) Gradually place your weight onto the helicopter. 3) behind, uphill 4) Moving crews and equipment and evacuating injured subjects. 5) A fast moving tail rotor is hard to see. 6) see page 12-9 7) F 8) T 9) F 10) F

Chapter 13 – Avalanche Orientation

No questions asked.

Chapter 14– Evacuation

1) Bend your legs (remember to keep back straight) 2) The First Aid Attendant 3) Not to kick rocks on the subject. 4) The GSTL may miss a safety hazard. 5) To cross an obstacle. 6) F 7) T 8) F 9) F 10) T

Chapter 15 – Initial Response Searches

- 1) Initial Response searches are rapid searches in the areas of highest probability.
- 2) Describe calling, sound or beacon procedures. 3) Describe the advantages, on page 15-13
- 4) They can destroy clues and engines can drown out the response of a subject.
- 5) see page 15-12
- 6) The size of the search area is reduced.
- 7) T 8) T 9) F 10) F 11) F

Chapter 16 – Sweep Searches

- 1) A responsive subject. 2) Methods that gives a quick but not particularly thorough search.
- 3) Contour search follows an elevation and a feature search follows a river, road, etc.
- 4) Cool or cold temperatures and little forest cover
- 5) Depends on subject, terrain type and available personnel and equipment
- 6) F (the searchers can start at the same time but do not have to)
- 7) F 8) F 9) F 10) T

Chapter 17 – Closed Grid Searches

- 1) Small search area, high probability subject is in search area, many searchers, subject unresponsive
- 2) A staggered line is used where the searchers can see a neighboring searcher and maintain spacing from that person.
- 3) See page 17-4
- 4) F 5) F (difficult areas are marked off and left for another search team) 6) F 7) T

Chapter 18 – Shoreline Searches and Shoreline Safety

- 1) On a bank, on a rock or island or against a log-jam
- 2) Move down along the shore
- 3) Facing upstream, leaning on a pole
- 4) Watch for any person swept downstream and use a throwbag to bring them into shore.
- 5) Helmet, PFD, knife, whistle and appropriate footwear
- 6) F 7) T 8) F 9) F 10) T